

# IRP-1: Isolation Relay Package

## 1.0 Purpose

The PXL-250 Tiger Controller, SB-293 Satellite Board, PXL-100 Smart Entry Controller, and SM-2000 IntelliProx Single Door Controller are designed with built-in voltage transient suppression. For most applications, this built-in protection is more than adequate - additional protection is not required. However, there are two applications that can require additional protection.

1. magnetic locking devices or dry-contact devices without built-in suppression (typically older models)
2. magnetic locking devices that draw large amounts of current (typically older models or defective devices)

For these applications, the IRP-1 should be used to isolate the PXL-250, SB-293, PXL-100, or SM-2000 from the transients these magnetic locking devices can generate, ensuring reliable operation of the controller.

## 2.0 Contents

The IRP-1 is made up of the following items.

- one printed circuit board containing an isolation relay, diode, and connector strip
- one transient suppression device (1.5KE39C nonpolarized transorb)
- double sticky-sided foam tape (for mounting)

## 3.0 Specifications

The IRP-1's relay is rated as follows.

7 Amps max. @ 30 VDC

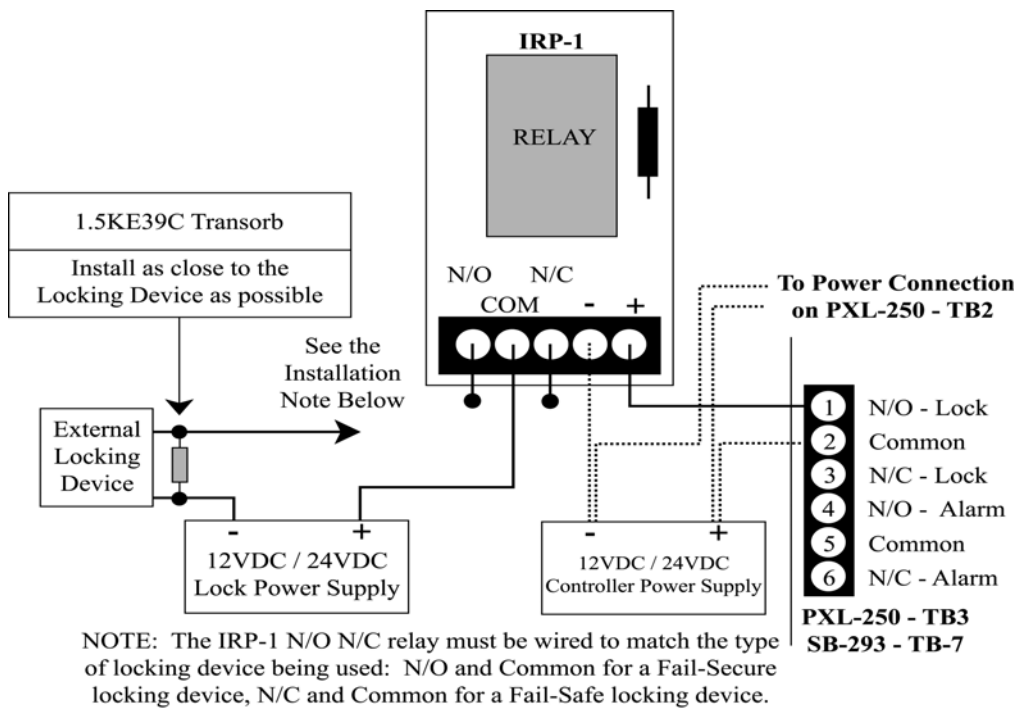
12 Amps max. @ 125 VAC

## 4.0 Application

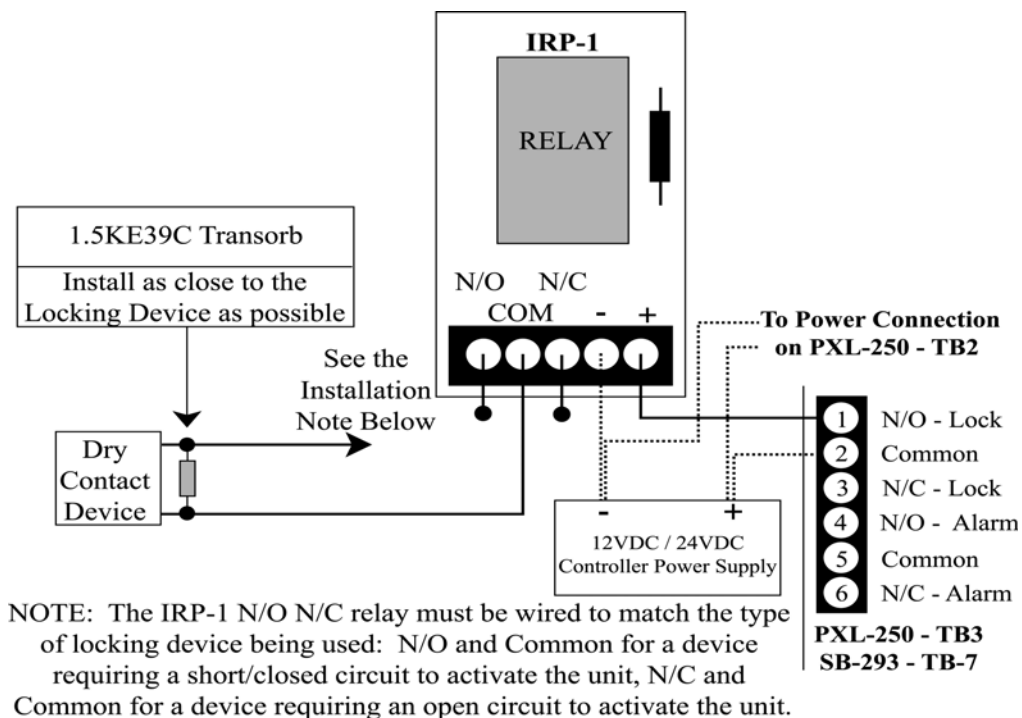
There are two primary applications for the IRP-1. It can be used with an external locking device (such as a magnetic lock or door strike) or with a dry-contact device (such as a switch or relay controlling a motor for a parking barrier or power gate). The wiring diagram is different for these two applications. Figures 1, 3, and 5 are wiring diagrams for adding an IRP-1 to an external locking device. Figures 2, 4, and 6 are wiring diagrams for adding an IRP-1 to a dry-contact device.

Install the IRP-1 as shown in Figures 1 through 6 to meet your application's requirements. If the application uses either 12 VDC or 24 VDC, install the supplied transorb as near to the external locking device or dry-contact device as possible. Do not install the transorb if the device is being powered with greater than 30 VDC.

# IRP-1: Isolation Relay Package

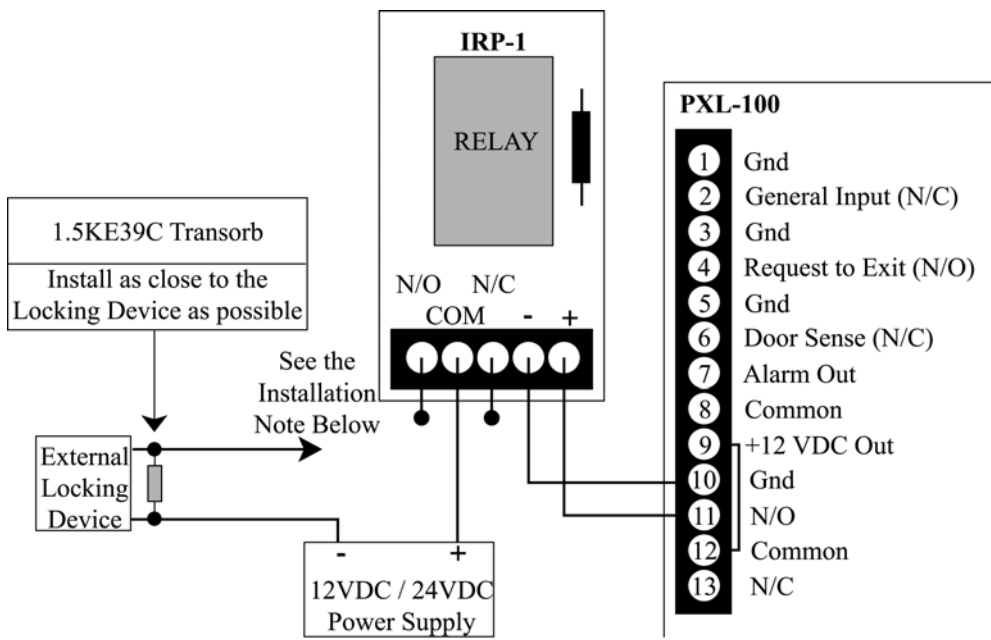


**Figure 1: Adding an IRP-1 to an External Locking Device - PXL-250/SB-293 Configuration**



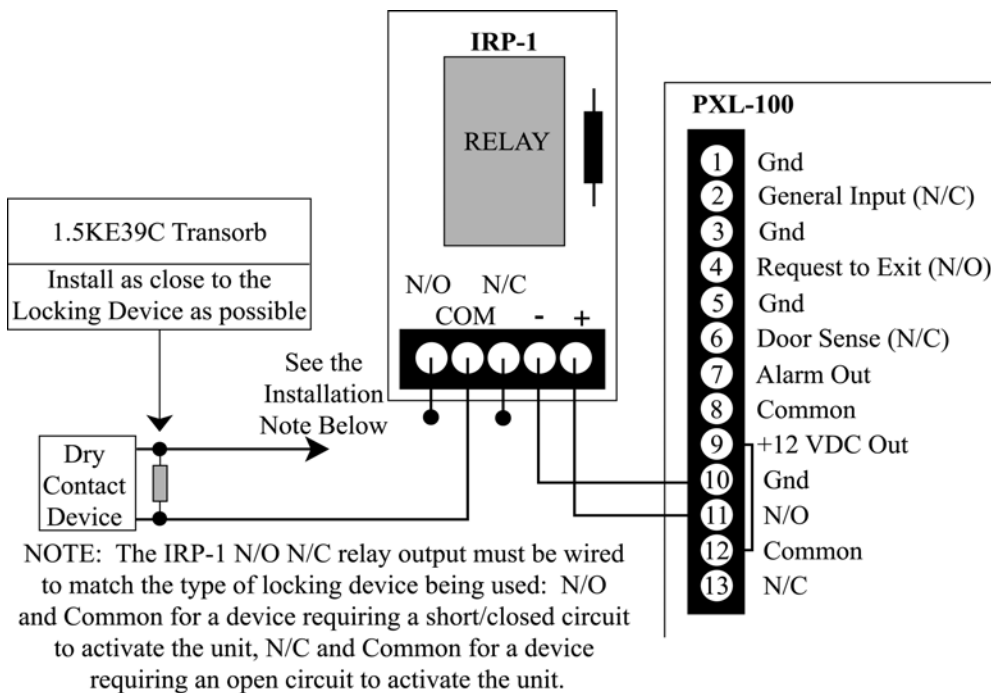
**Figure 2: Adding an IRP-1 to a Dry-Contact Device - PXL-250/SB-293 Configuration**

# IRP-1: Isolation Relay Package



NOTE: The IRP-1 N/O N/C relay must be wired to match the type of locking device being used: N/O and Common for a Fail-Secure locking device, N/C and Common for a Fail-Safe locking device.

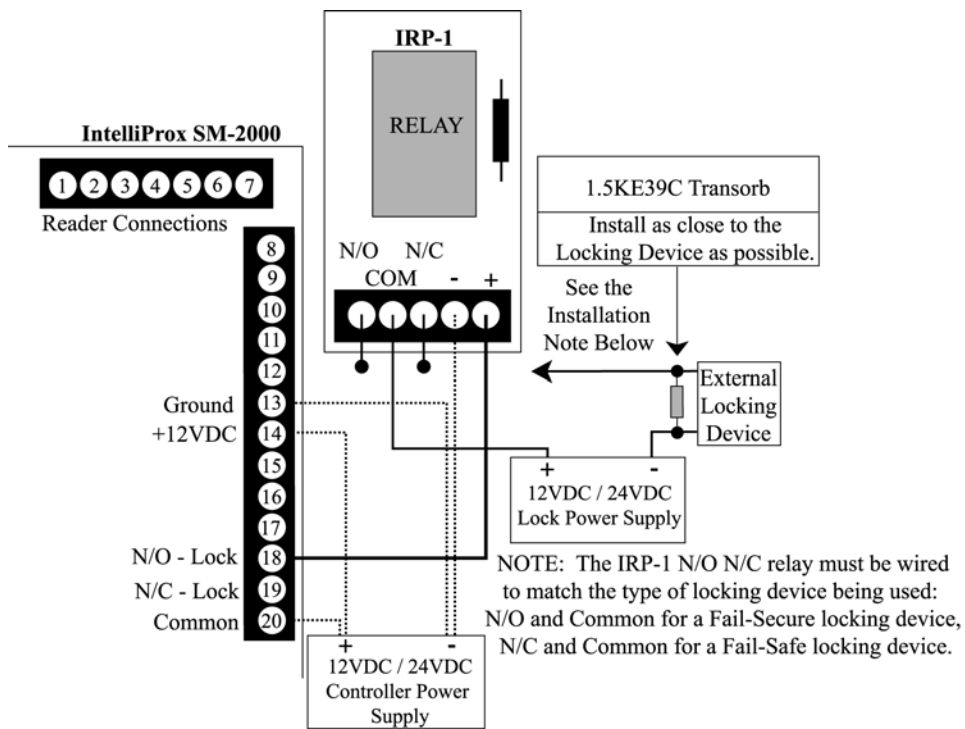
**Figure 3: Adding an IRP-1 to an External Locking Device - PXL-100 Configuration**



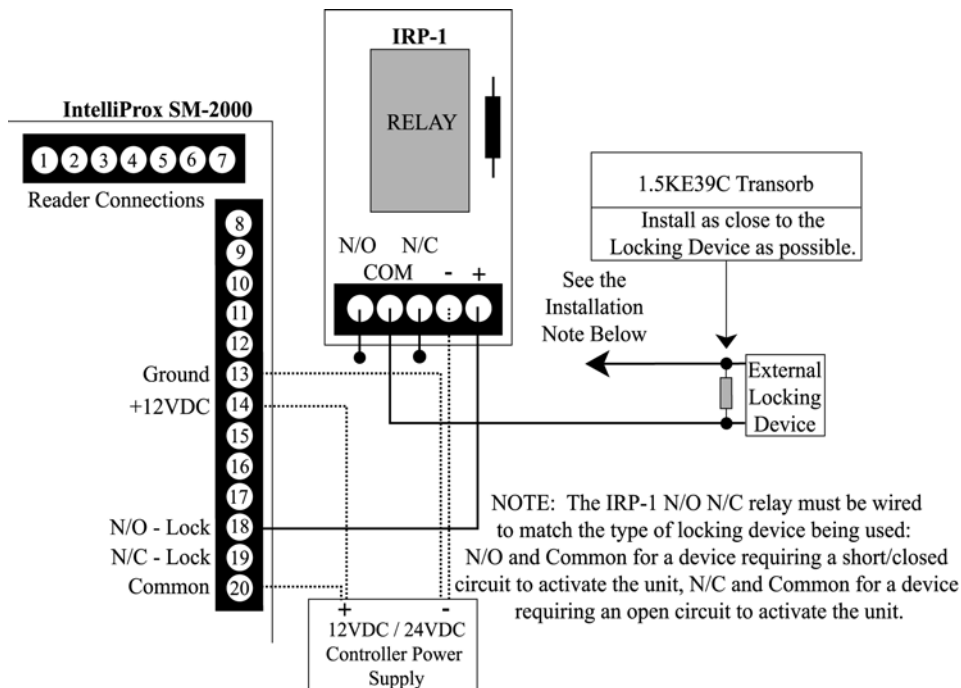
NOTE: The IRP-1 N/O N/C relay output must be wired to match the type of locking device being used: N/O and Common for a device requiring a short/closed circuit to activate the unit, N/C and Common for a device requiring an open circuit to activate the unit.

**Figure 4: Adding an IRP-1 to a Dry-Contact Device - PXL-100 Configuration**

# IRP-1: Isolation Relay Package



**Figure 5: Adding an IRP-1 to an External Locking Device - SM-2000 Configuration**



**Figure 6: Adding an IRP-1 to a Dry-Contact Device - SM-2000 Configuration**