

# LAN-505 Ethernet Communication

## 1.0 Purpose of this Document

This document discusses how to setup, configure, and use the LAN-505 Universal Device Server to provide LAN/WAN Ethernet connectivity between *Doors*<sup>TM</sup> and one or more PXL networks<sup>1</sup>. The following topics are covered:

- Overview
- System Requirements
- LAN-505 Setup
- *Doors*/Workstation Setup
- Using the LAN-505 with Multiple PXL Networks
- Basic Ethernet Troubleshooting

## 2.0 Overview

At Keri Systems, we are always looking for ways to improve our product and provide solutions to the various implementation requests we receive. One of the most asked for requests is “Can you provide low-cost network capabilities to *Doors* and a PXL Network?” Although *Doors* was developed as a stand-alone application, there are a few ways to use *Doors* in a network<sup>2</sup>.

The main limitation when using *Doors* in a network has been that the communication to the PXL network could only come from the host workstation physically connected to the master controller of the PXL network<sup>1</sup>. This prevents other workstations from using *Doors* to update or control the PXL network unless either some sort of third party, remote control software application is used or by sharing the *Doors* folders over a network which places limits on what can be done.

Keri Systems now has a low-cost solution to this problem. The LAN-505 allows the PXL network to be attached to a Local Area Network (LAN) instead of directly to a host workstation. This gives any workstation on a LAN (with the proper authority) the ability to communicate with the PXL network. To do this, two things must happen.

1. On the host workstation, the *Doors* folder must be shared.
2. A shortcut to the *Doors*.EXE program in this folder must be created on each client workstation that needs to be able to run the *Doors* program. Every client workstation with a shortcut to *Doors*.EXE can double-click on the shortcut and start the *Doors* program.

*NOTE: Do NOT install the Doors software on each client workstation; this will create unique databases on each system. By creating a shortcut on each client workstation to the shared kerisys folder on the host workstation, each client workstation is able to use the Doors installation on the host workstation, sharing the original database set.*

---

1. The LAN-505 may be used with a PXL-500/PXL-510 only.  
2. See the [Doors in a Network Environment](#) Application Note for more information – P/N 01867-001.

# LAN-505 Ethernet Communication

In a LAN-505 network, when a host workstation communicates with the access control network, *Doors* converts data sent to the designated serial port into an Ethernet packet, opens an IP socket, and then sends the packet to the designated LAN-505. The LAN-505 receives the packet and sends the data to the PXL network through the LAN-505's serial port (see Figure 1).

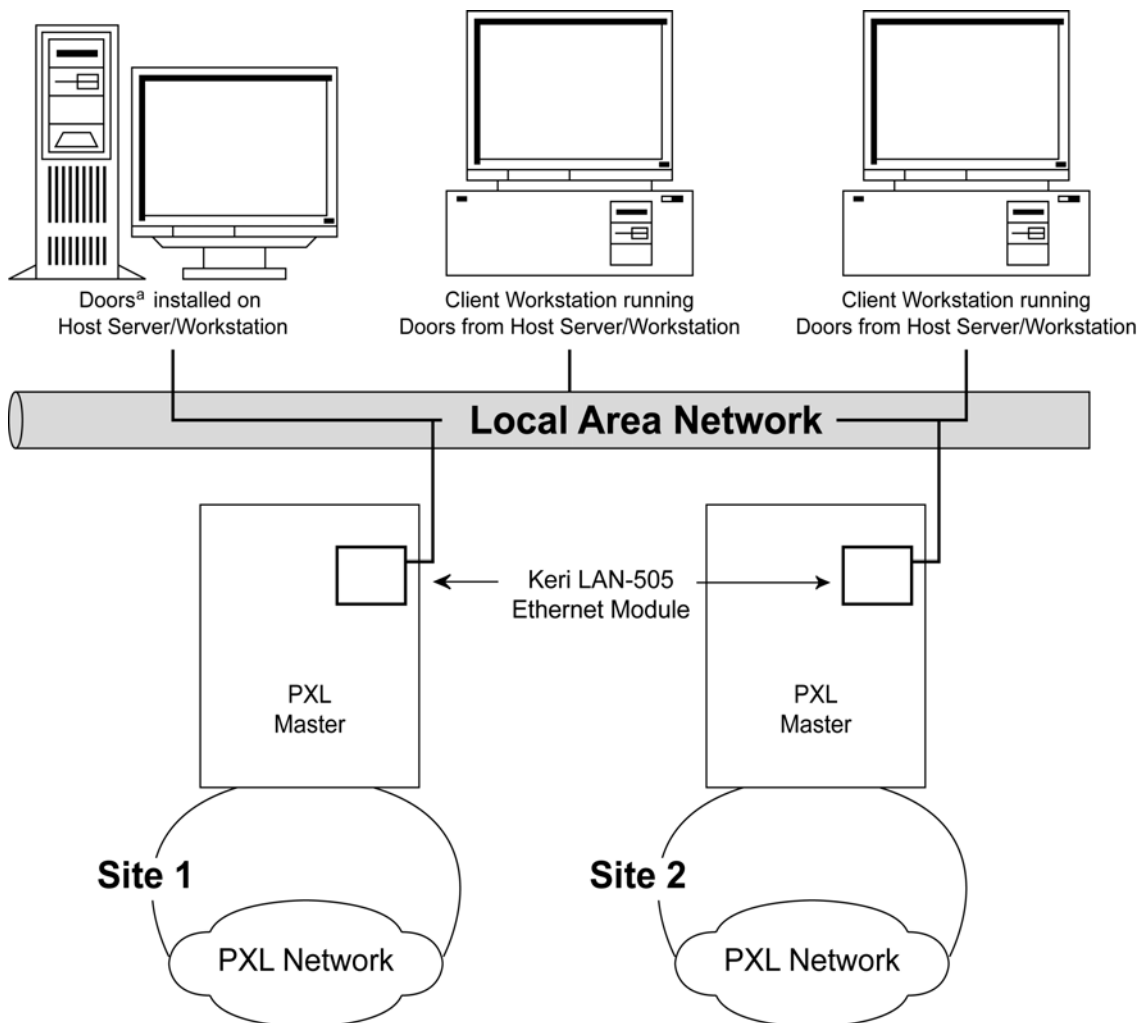

a. For use with a LAN-505 Doors v4.10 or greater must be used.

**Figure 1: Using *Doors* on a LAN Using the LAN-505**

The IP socket identifies which client workstation is communicating with the LAN-505 so that when the access control network communicates with the client workstation, the data is routed back correctly.

When using the LAN-505, the transfer of data through the LAN is transparent to both the *Doors* program and the PXL network. This method of communication between host workstation and access control network is very robust; however there are some special considerations.

# LAN-505 Ethernet Communication

- *Doors* software beginning with version 4.10 supports direct communication to the LAN-505. Refer to the [Doors Users Guide](#) (P/N 01914-100) for *Doors* software configuration information
- Whenever a *Doors* database is opened (i.e. setup users, time zone, access group, controller, door), a copy of that database is saved on the user's client workstation. All changes made by the user are made to that local copy. The original database used by the *Doors* program on the file server or shared folder does not receive these changes until the user clicks on the **SAVE** button, physically overwriting the original database in the file server or shared folder with the newly edited information from the user's client workstation. This is done to protect the original database from being affected if a user decides to cancel any changes being made.
- Although multiple users can simultaneously work in the *Doors* program, only one workstation can communicate with the PXL access control network at a time (whether directly or via remote access software). There is no way to simultaneously control an access control network from more than one workstation. This means that only one user at a time may be downloading information to the network, receiving information from a network, monitoring a network, or manually operating a network. When that user has completed work, that user must use the Net Disconnect command (the Operate > Net Disconnect pull-down menu option) to manually disconnect from the access control network and that user must close the *Doors* program to allow another user to gain access to the access control network. If more than one workstation is connected to the network at the same time, the first workstation to have changes saved will be the only one connected to the network. All other workstations will not have changes saved until the Net Disconnect has been used at the first workstation.

***NOTE: Using shortcuts to download information to the network, receive information from a network, monitor a network, or manually operate a network may corrupt the Doors database (Windows error code 70 or 120). If a shortcut will be used (from a computer that does not have Doors installed), a current backup of the Doors database should be kept.***

- There is no encryption available to hide the data going across the LAN. Ethernet, by its nature, is not secure.
- Only one site (or network) may be monitored at any one time.

# LAN-505 Ethernet Communication

---

## 3.0 System Requirements

Both the server and the client workstations, and the LAN must meet the following system requirements for proper operation of *Doors* and the LAN-505.

- PC compatible computer using a Pentium™-90 or faster microprocessor
- minimum of 16 MB of system RAM
- SVGA color monitor with SVGA graphics card (800 x 600 minimum resolution for use with small fonts and 1024 x 768 minimum resolution for use with large fonts)
- CD-ROM, keyboard, and mouse or other pointing device
- 3.5 inch floppy disk drive or CD-ROM burner (optional for system backup)
- 100 MB of available hard disk space
- 10BaseT (or greater) network card
- twisted-pair network cabling (NOT coax)
- TCP/IP network protocol running in a *Windows* network
- one of the following operating systems
  - *Windows 95™*
  - *Windows 98™*
  - *Windows 2000™*
  - *Windows ME™*
  - *Windows XP™*
  - *Windows NT™*

# LAN-505 Ethernet Communication

## 4.0 LAN-505 Setup

LAN-505 setup is done in three steps.

1. Connect the LAN-505 to the LAN.
2. Set the LAN-505's IP address.
3. Configure the LAN-505.

Once the LAN-505 is setup, the *Doors* program must be configured to communicate with this unit. Please refer to the *Doors Users Guide* (P/N 01914-100) for *Doors* configuration information.

*NOTE: To set up the LAN-505 you must have a technical knowledge of networks and networking in a PC environment. Please consult your System or Network Administrator to resolve any networking issues that might occur.*

### 4.1 Connect the LAN-505 to the LAN

1. Power down the PXL-500/PXL-510 master controller.
2. On the master controller, remove the jumpers from JP6 and JP7 (see Figure 2).
3. Connect the LAN-505's 10/100 Ethernet/MAC port to the LAN port designated for use by the LAN-505.
4. Insert the LAN-505's U6 connector pins (located on the underside of the LAN-505) into the PXL-500's TB13 (see Figure 2 for location of connection).

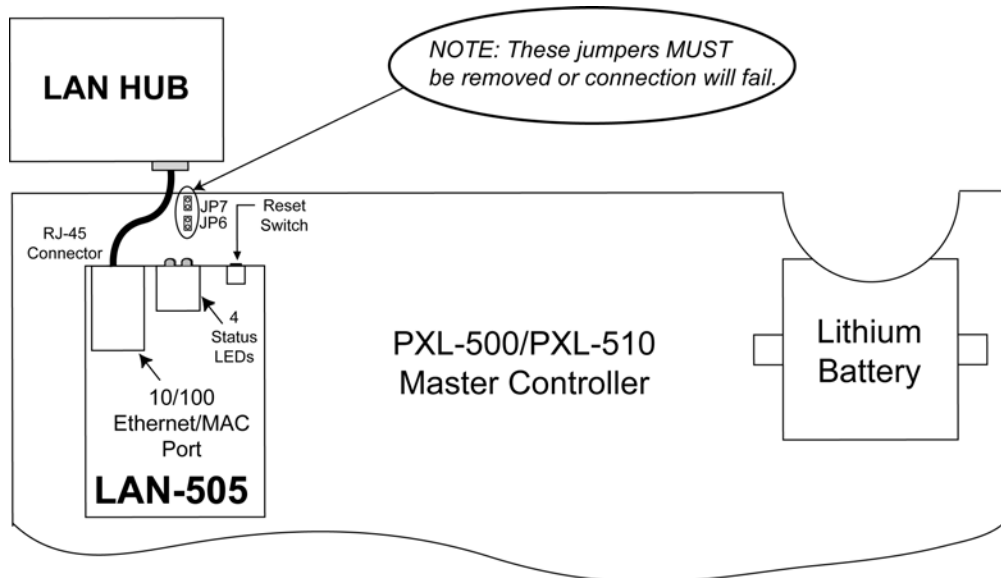

Figure 2: LAN-505 Connection Diagram

# LAN-505 Ethernet Communication

## 4.2 Set the LAN-505's IP Address

Two things must be done before assigning an IP address to a LAN-505 to uniquely identify the LAN-505 on the LAN.

1. Get the Ethernet/MAC address of the LAN-505. On the LAN-505, the Ethernet/MAC address is found on the label placed on the underside of the unit (see Figure 3).
2. Obtain a unique IP address to assign to the LAN-505. The IP address is assigned by the LAN Administrator. Contact the LAN Administrator for this number.

*NOTE: If the LAN-505 is installed on a static network or using cross-over cable, the unit will auto address to 169.254.x.x and a class b subnet 255.255.0.0.*

Once you have this information you are ready to assign an IP address to the LAN-505.

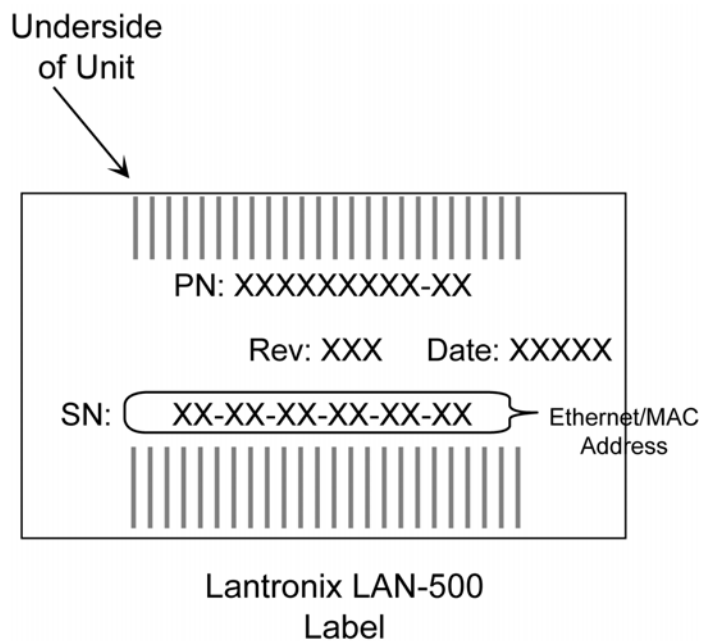

**Figure 3: Locating the Ethernet/MAC Address**

There are two methods that you can use to assign the IP Address to the LAN-505 depending upon the type of LAN-505 access available to you.

- If your host computer has a web browser, you can use the Lantronix DeviceInstaller.
- If a web browser is not available, you can use the operating system's Telnet program.

## 4.2.1 IP Address Assignment Using the Lantronix DeviceInstaller

Setting the IP Address via the Lantronix DeviceInstaller is simple, however to use this method you must first download Microsoft® .NET and the Lantronix DeviceInstaller. The Microsoft® .NET installation and Lantronix DeviceInstaller is located on the *Doors* CD-ROM, or may be downloaded from the following locations:

Microsoft® .NET

<ftp://ftp.lantronix.com/pub/DeviceInstaller/dotnetfx.exe>

Lantronix DeviceInstaller

<ftp://ftp.lantronix.com/pub/DeviceInstaller/v3.6/DeviceInstaller36.zip>

**NOTE:** Using the Lantronix DeviceInstaller to assign the IP address is only possible when the installation takes place on the same LAN segment. If the LAN device is located outside the Local LAN segment, the IP address must be assigned manually (see “IP Address Assignment Using Telnet” on page 19).

### 4.2.1.1 Installation of Microsoft® .NET

The first step to using the Lantronix DeviceInstaller is to download and install Microsoft® .NET.

1. Load the installation CD into the CD-ROM of the host computer. The AutoRun Menu appears (see Figure 4).



**Figure 4: Keri CD-ROM AutoRun Menu**

2. Click on the **Explore the CD-ROM** link. Windows Explorer opens and displays the CD-ROM contents (see Figure 5 on page 8).

# LAN-505 Ethernet Communication

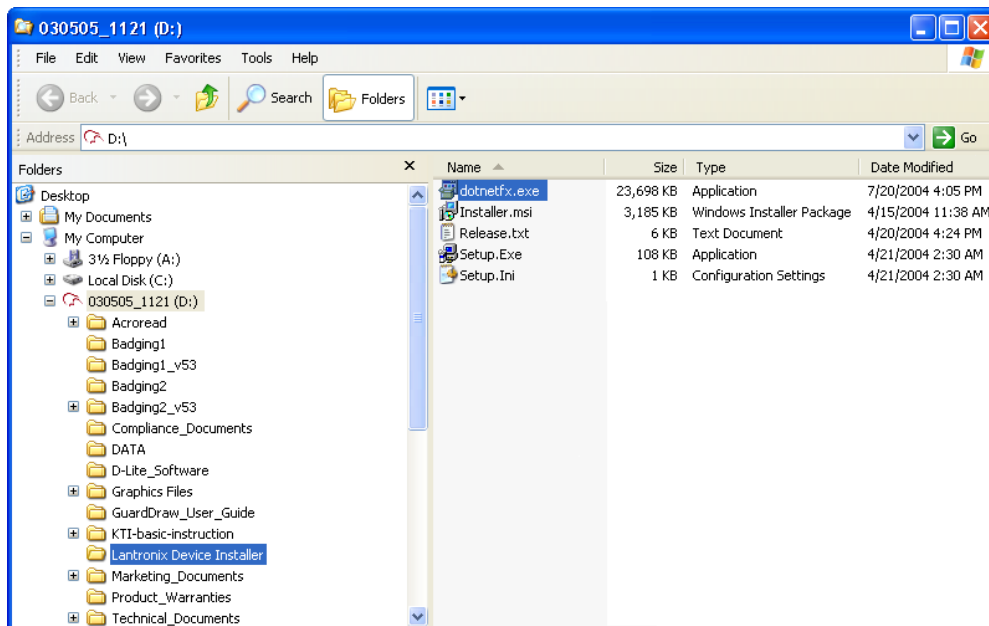

Figure 5: Windows Explorer

3. Double-click on the dotnetfx.exe link. A confirmation window appears asking if the Microsoft .NET Framework package should be installed (see Figure 6).

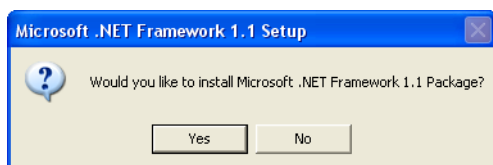

Figure 6: Microsoft .NET Installation Confirmation

4. Click on the  button to begin setup of the installation. A window appears showing the progress of the setup (see Figure 7).

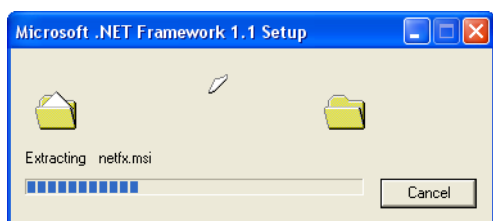
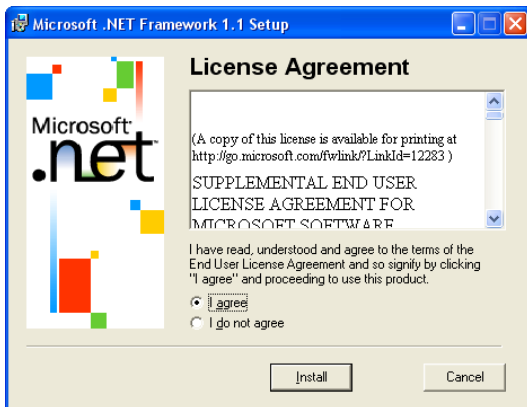



Figure 7: Microsoft .NET Setup In Progress

5. Once the setup is complete, a license agreement appears (see Figure 8).



**Figure 8: Microsoft .NET Installation License Agreement**

6. Use the scroll bar on the right side of the window to review the .NET license agreement. After viewing the agreement, click on the “I agree” radio button and then click on the  button.
7. Microsoft .NET begins installation (see Figure 9).

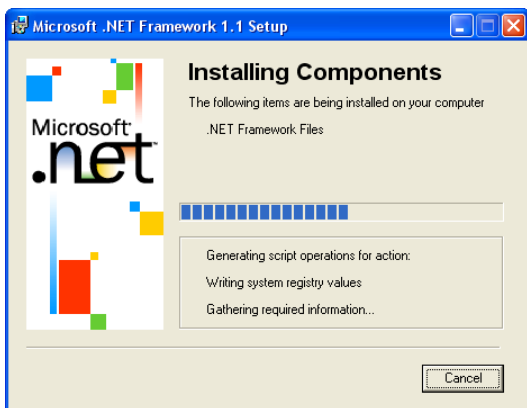

**Figure 9: Microsoft .NET Installation Progress**

8. When the installation is complete, a window appears (see Figure 10). Click on the  button.

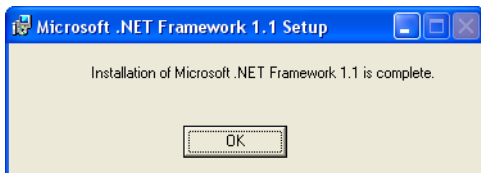

**Figure 10: Installation Complete**

# LAN-505 Ethernet Communication

## 4.2.1.2 Installing the Lantronix Device Installer...

Once Microsoft® .NET has been installed, the next step is to install the Lantronix DeviceInstaller.

1. Load the installation CD into the CD-ROM of the host computer. The AutoRun Menu appears (see Figure 4 on page 7).
2. Click on the **Explore the CD-ROM** link. Windows Explorer opens and displays the CD-ROM contents (see Figure 11).

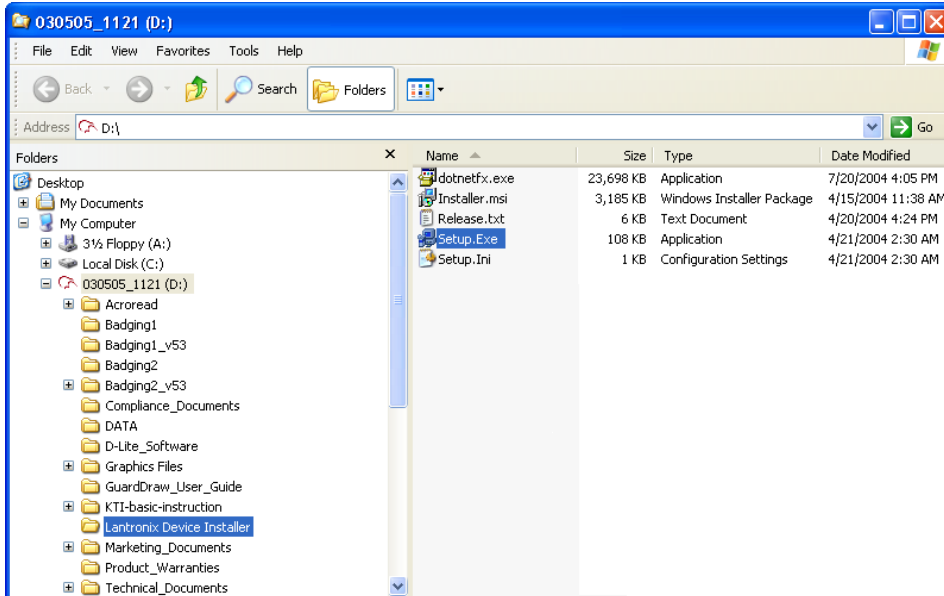



Figure 11: Windows Explorer - DeviceInstaller Setup.exe

3. Double-click on the  Setup.exe link. (see Figure 6). The Welcome to the DeviceInstaller Setup Wizard window appears (see Figure 12).

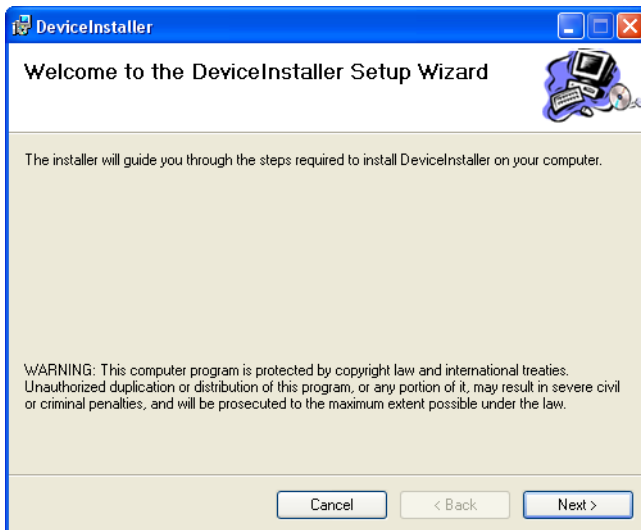
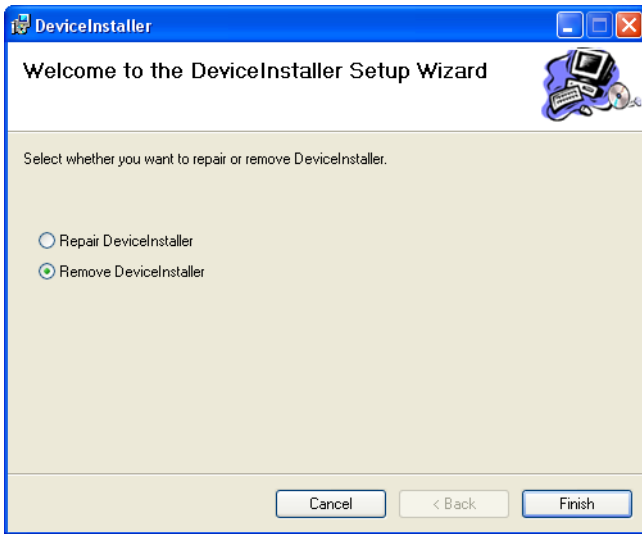

Figure 12: DeviceInstaller Setup Wizard

# LAN-505 Ethernet Communication

4. If a DeviceInstaller is already installed on the system, a different window will appear allowing the repair or removal of the installed software (see Figure 13).



**Figure 13: Alternate DeviceInstaller Setup Wizard Welcome Window**

5. Continuing on from Figure 12 for a new installation, click on the **Next >** button to begin the installation process. The Select Destination Location window appears (see Figure 14).

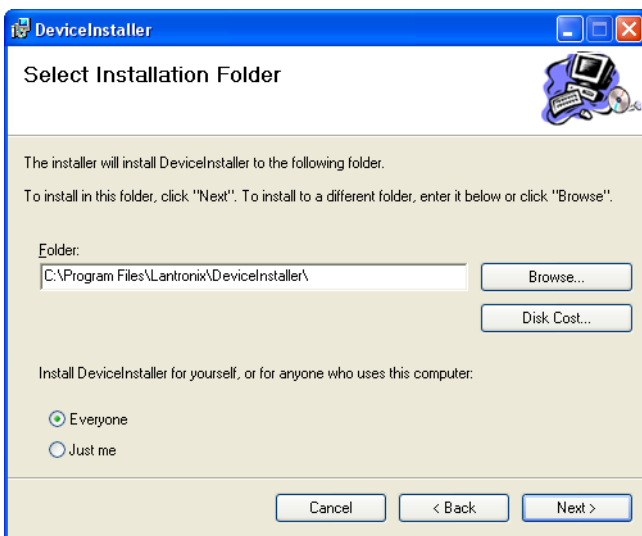
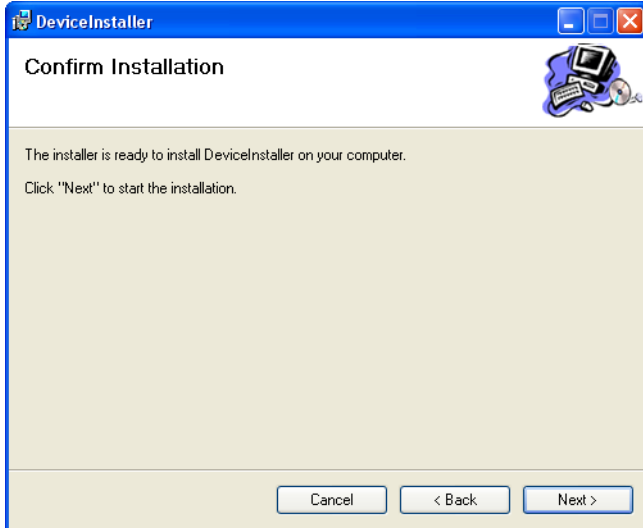

**Figure 14: Select Destination Folder**

6. In most instances, the default folder is the best place for installing the DeviceInstaller. If a different directory must be used, click on the **Browse...** button, navigate to the directory to which the DeviceInstaller should be installed, and then click on the **OK** button.

# LAN-505 Ethernet Communication

7. Decide whether everyone who uses the computer with DeviceInstaller on it should have access to the DeviceInstaller or only the person logged on during this first installation. Select the Everyone radio button if everyone should have access to the DeviceInstaller, or select the Just Me radio button for only the person currently logged on.
8. Click on the  button. A confirm installation window appears (see Figure 15).



**Figure 15: Confirm Installation of DeviceInstaller**

9. To begin the DeviceInstaller installation, click on the  button. An installation progress window appears (see Figure 16).

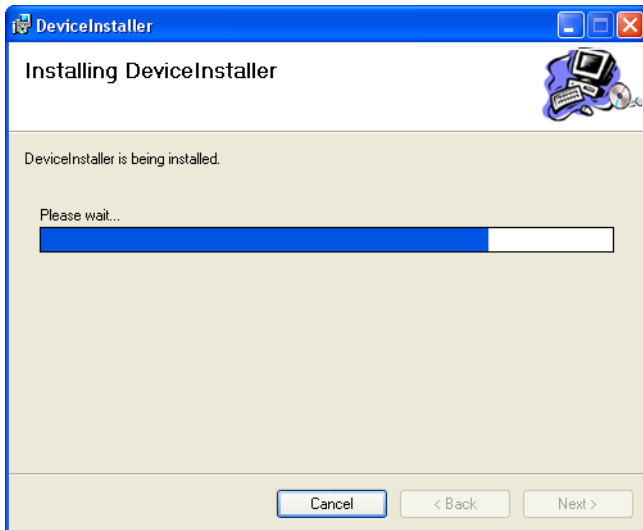

**Figure 16: Installation Progress Window**

10. An Installation Complete window will appear when the DeviceInstaller has been successfully installed (see Figure 17 on page 13).

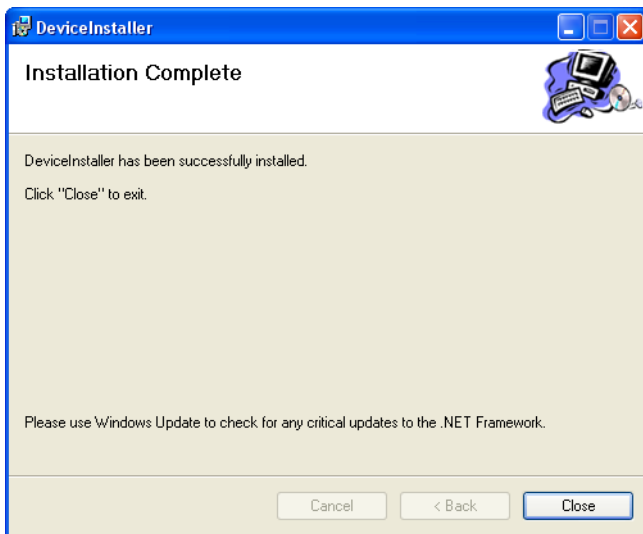

**Figure 17: Installation Complete Window**

11. Click on the  button to exit the installation window.
12. You are now ready to assign the IP address.

# LAN-505 Ethernet Communication

## 4.2.1.3 Assigning the IP Address using DeviceInstaller

1. From the Windows Taskbar, click on Start > All Programs > Lantronix > DeviceInstaller > DeviceInstaller to start the configuration program. The DeviceInstaller program opens (see Figure 18).

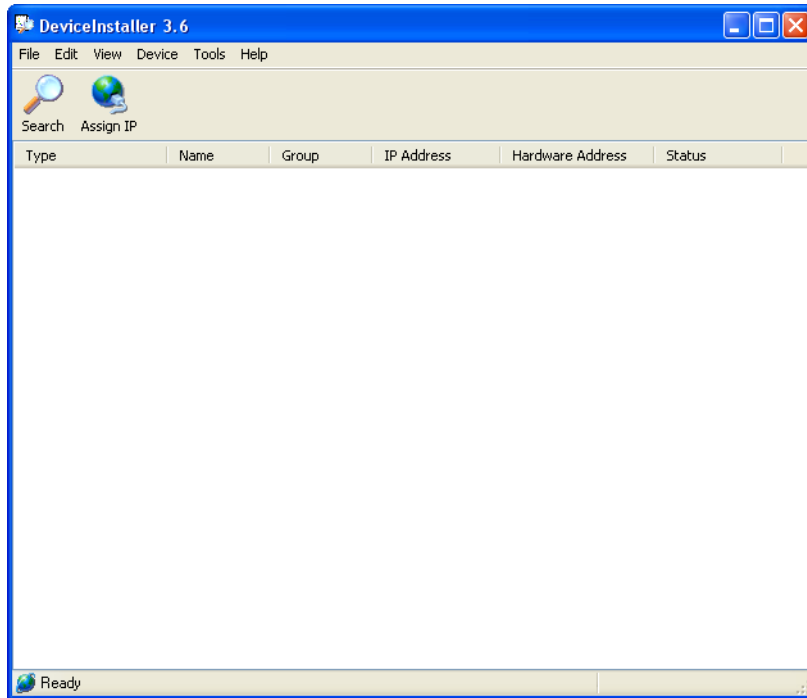



Figure 18: The DeviceInstaller Program Window

2. Click on  Search to locate the LAN-505. An IP address needs to be set information window appears (see Figure 19).

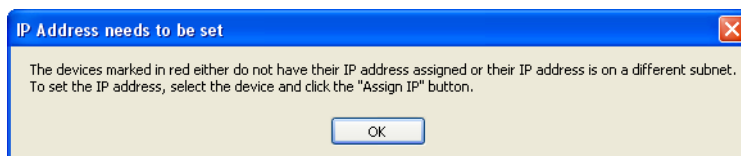



Figure 19: IP Address Needs to be Set

3. Click on the  button. A list of devices is displayed showing IP address, hardware address and device status (see Figure 20 on page 15).

# LAN-505 Ethernet Communication

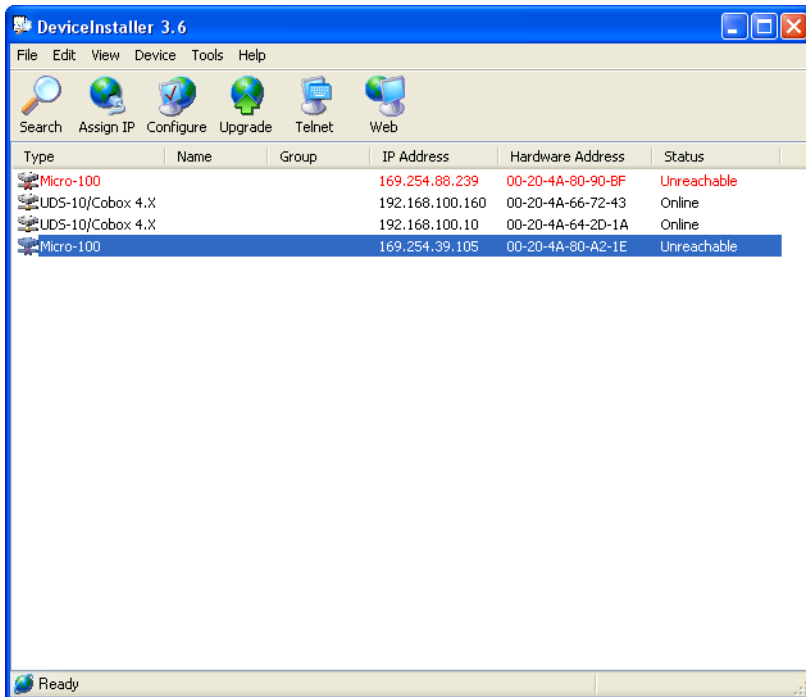



Figure 20: Device Listing Window

4. Locate and select the LAN-505 to be assigned an address by selecting the device with a hardware address that matches the one assigned the LAN-505 (the hardware address is found on a sticker placed on the backside of the LAN-505).

*NOTE: The LAN-505 will not appear if it is not properly connected to the LAN. If the LAN-505 is not listed here, check all connections and try the search button again.*

5. Click on  to assign an IP address to the LAN-505. The Assignment Method Window appears (see Figure 21 on page 16).

# LAN-505 Ethernet Communication

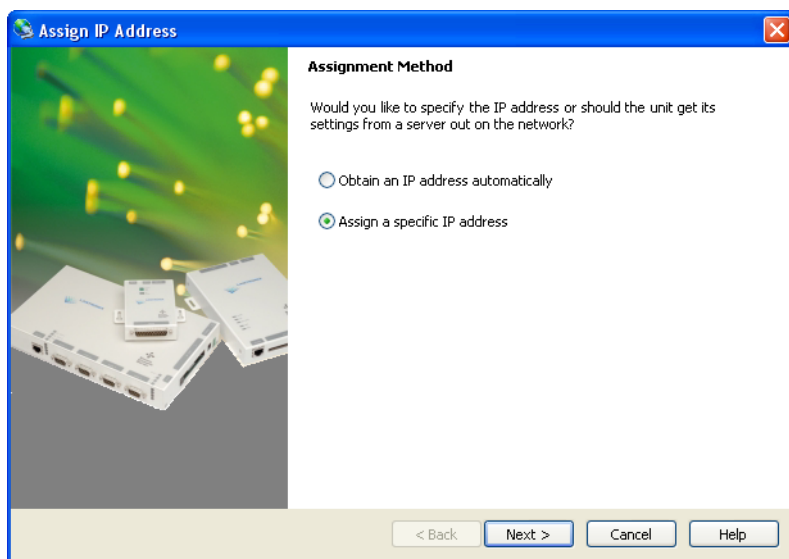



Figure 21: Assignment Method Window

6. Click on the Assign a specific IP address radio button, then click on the  button. The IP Settings window appears (see Figure 22).

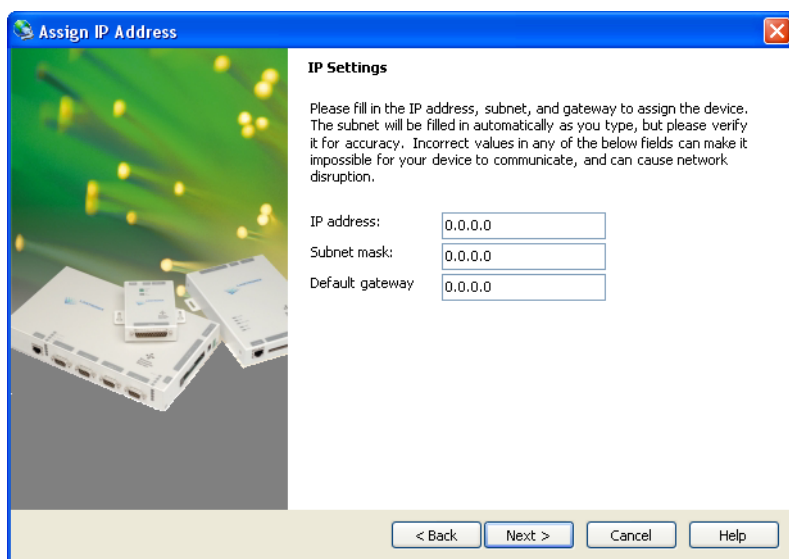
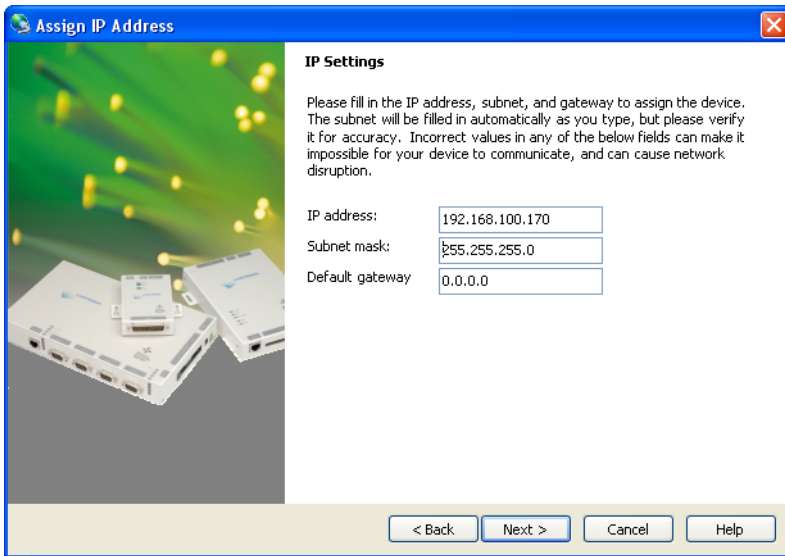

Figure 22: IP Settings Window

7. Click in the "IP Address" field and enter the IP address to be used with the LAN-505.
8. Click in the "Subnet mask" field. The Subnet mask is automatically updated to match the IP address entered (see Figure 23 on page 17).



**Figure 23: IP Settings Window - Completed**

- Click on the  button. If the entered IP Address is in use by another device, an error window appears (see Figure 24). Click the  button to clear the window, verify the IP Address is correct and there is no conflict with any existing devices/IP Addresses on the network, and start again from Step 2 on page 14.

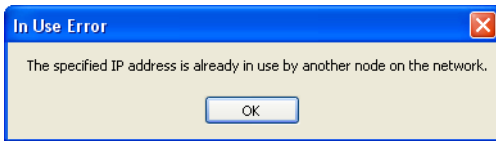

**Figure 24: IP Address Already in Use Error**

- Another possible error is if the LAN-505 does not respond. This is indicative of some type of communication error. Verify the **Ethernet** Address is correct, verify the network cabling is correct, and start again from Step 2 on page 14.

*NOTE: If the LAN-505 continues to not respond, follow the directions beginning in Section 4.2.2 on page 19 to assign the IP address using Telnet.*

# LAN-505 Ethernet Communication

11. If the IP Address is not in use and the unit responds, the Assignment Window appears (see Figure 25).

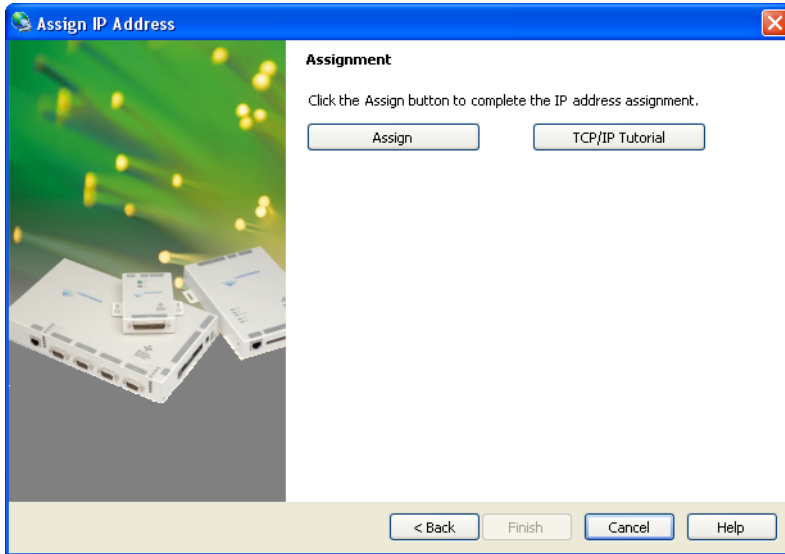

**Figure 25: Assignment Window**

12. Click on the  button. The IP Address assignment begins. This process may take up to a minute. Once the process is completed, the window will display “Completely successfully” at the bottom of the window (see Figure 26).

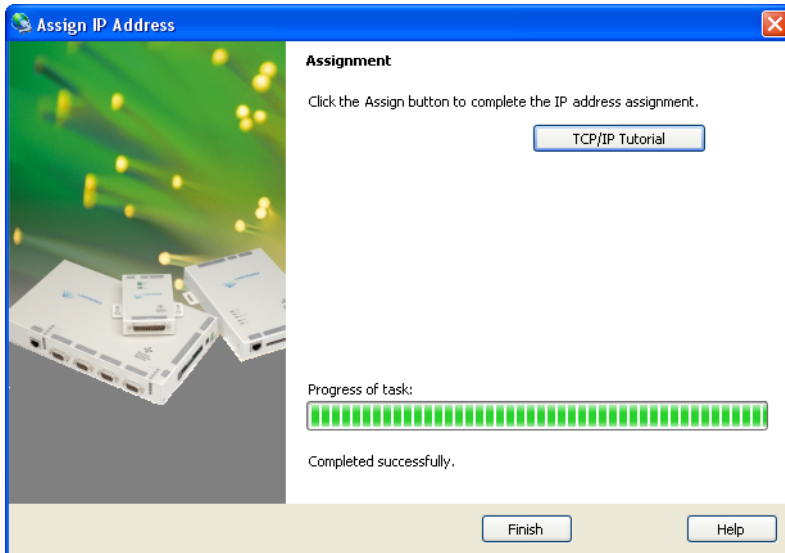

**Figure 26: IP Address Assignment Successful**

13. Click  to close the DeviceInstaller window.

# LAN-505 Ethernet Communication

## 4.2.2 IP Address Assignment Using Telnet

The LAN-505 takes its IP address from the first TCP/IP packet directed to that unit via the unit's Ethernet/MAC address. Once the first packet with the IP address has been sent, Telnet is used to permanently set this IP address in the unit.

1. From the DeviceInstaller page (see Figure 20 on page 15), click on the  button or open a DOS box.
2. Check the contents of the ARP table; the table must have at least one IP address entry and that entry **cannot** be the host workstation's IP address.

At the DOS prompt type the following to verify the contents of the ARP table:

```
- c:\>arp -a <Enter>
```

If the table displays one or more non-host workstation IP addresses (see Figure 27), skip to Step 3.

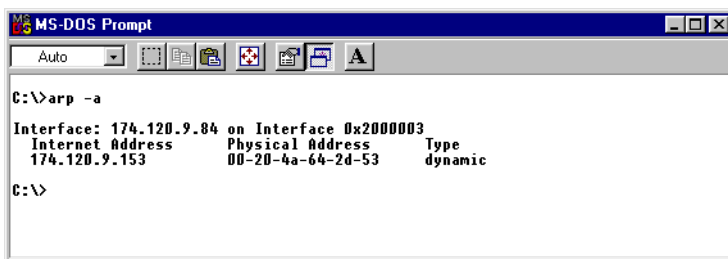

Figure 27: ARP Table Contents

If the table is empty a “No ARP Entries Found” message is displayed. To create an entry in the ARP table, ping the IP address of another device or workstation on the LAN (this IP address **cannot** be the IP address of the host workstation).

```
- c:\>ping <other IP Address> <Enter>
```

For example:

```
- c:\>ping 174.120.9.153 <Enter>
```

After the device with this IP address replies, this IP address is entered into the ARP table.

# LAN-505 Ethernet Communication

3. Send the LAN-505's IP address to the LAN-505.

At the DOS prompt, type the following to send the LAN-505's IP address to the LAN-505 (see Figure 28):

```
- c:\>arp -s <LAN-505 IP address> <LAN-505 Ethernet/MAC address> <Enter>
```

For example:

```
- c:\>arp -s 174.120.9.115 00-20-4A-24-89-67 <Enter>
```

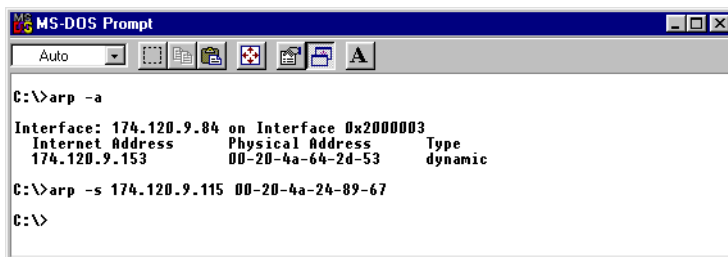

**Figure 28: Send IP Address Via ARP Command**

*NOTE: The ARP command does not report whether or not this command is completed successfully.*

4. Open a Telnet connection to Port 1 on the LAN-505. A Telnet “Connection Failed” screen appears, but since this Telnet connection is the first TCP/IP packet sent to the LAN-505, the LAN-505 enters that IP address into its server configuration table.

At the DOS prompt type the following to make the Port 1 Telnet connection to the LAN-505:

```
- c:\>telnet <LAN-505 IP address> 1 <Enter> – a Telnet “Connection Failed” screen appears
```

For example:

```
- c:\>telnet 174.120.9.115 1 <Enter> – a Telnet “Connection Failed” screen appears
```

# LAN-505 Ethernet Communication

5. Close that Telnet window and open a new Telnet connection to Port 9999 on the LAN-505.

At the DOS prompt type the following to make the Port 9999 Telnet connection to the LAN-505:

```
- c:\>telnet <LAN-505 IP address> 9999 <Enter>
```

For example:

```
- c:\>telnet 174.120.9.115 9999 <Enter>
```

The following screen appears:

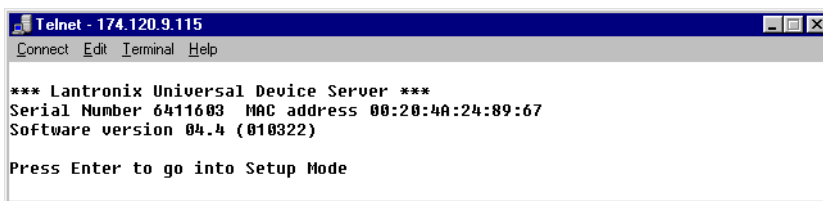
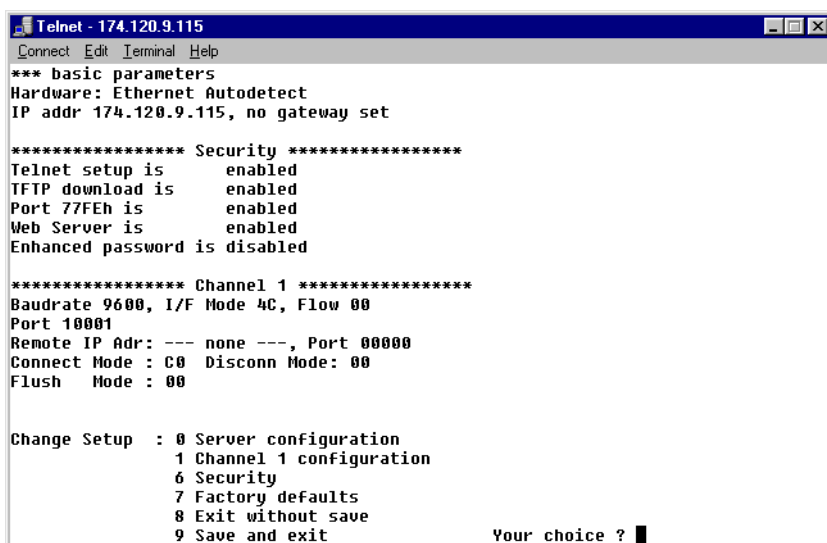

**Figure 29: Telnet Sign-on Screen**

6. Press <Enter> to go into the LAN-505 Setup mode as soon as the Telnet sign-on screen appears (see Figure 29). There is a two to three second delay in which you must press <Enter> before the Telnet session automatically closes. If the Telnet session closes before you enter Setup mode (if a “Connection to host lost” message appears), simply click the  box to clear the connection lost message and repeat the Telnet connection command in Step 5.
7. Once Telnet connects with the LAN-505 all current configuration information is displayed and the cursor is placed at the “Your choice” field (see Figure 30 on page 22). Verify the IP address displayed at the top of the Telnet window and also listed under the unit’s basic parameters is the IP address you assigned to the unit.

If the IP address is not correct, press 8 <Enter> to close the Telnet window and then repeat this procedure beginning with Step 3.

# LAN-505 Ethernet Communication



```
Telnet - 174.120.9.115
Connect Edit Terminal Help
*** basic parameters
Hardware: Ethernet Autodetect
IP addr 174.120.9.115, no gateway set

***** Security *****
Telnet setup is      enabled
TFTP download is    enabled
Port 77FEh is       enabled
Web Server is       enabled
Enhanced password is disabled

***** Channel 1 *****
Baudrate 9600, I/F Mode 4C, Flow 00
Port 10001
Remote IP Addr: --- none ---, Port 00000
Connect Mode : C0  Disconn Mode: 00
Flush  Mode : 00

Change Setup : 0 Server configuration
                1 Channel 1 configuration
                6 Security
                7 Factory defaults
                8 Exit without save
                9 Save and exit
                Your choice ? █
```

Figure 30: Configuration Parameter Entry Screen

- Press 9 <Enter> to save the assigned LAN-505 IP address. A “Connection to host lost” message appears. Click the  box to clear the connection lost message, then close the Telnet window and close the DOS box. The IP address is now entered into the LAN-505’s configuration table.

# LAN-505 Ethernet Communication

## 4.3 Resetting or Rebooting a LAN-505

Resetting a LAN-505 restores all serial port parameters to the factory default values. Rebooting a LAN-505 restarts the unit should the unit be hung up.

*NOTE: If you need to change an IP address on a LAN-505, this can only be done through the DeviceInstaller program. Simply follow the steps for assigning an IP address (see Section 4.2.1 on page 7). However, Telnet must be used if the IP address is outside of the subnet scheme for the LAN (see Section 4.2.2 on page 19).*

### 4.3.1 Resetting the Unit

Resetting a LAN-505 **must** be done via Telnet.

1. Open a Telnet connection to Port 9999 on the LAN-505.

At the DOS prompt type the following to make the Port 9999 Telnet connection to the LAN-505:

- c:\>telnet <LAN-505 IP address> 9999 <Enter>

For example:

- c:\>telnet 174.120.9.115 9999 <Enter>

The following screen appears:

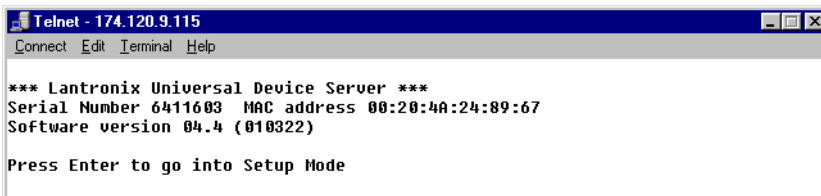

**Figure 31: Enter Telnet**

2. Press <Enter> to go into the LAN-505 Setup mode as soon as the Telnet sign-on screen appears. There is a two to three second delay in which you must press <Enter> before the Telnet session automatically closes. If the Telnet session closes before you enter Setup mode (if a "Connection to host lost" message appears), simply click the  box to clear the message and repeat the Telnet connection command in Step 1.
3. Once Telnet connects with the LAN-505 all current configuration information is displayed and the cursor is placed at the "Your choice" field (see Figure 16 on page 15). The IP address is displayed at the top of the Telnet window and also listed under the unit's basic parameters.

# LAN-505 Ethernet Communication

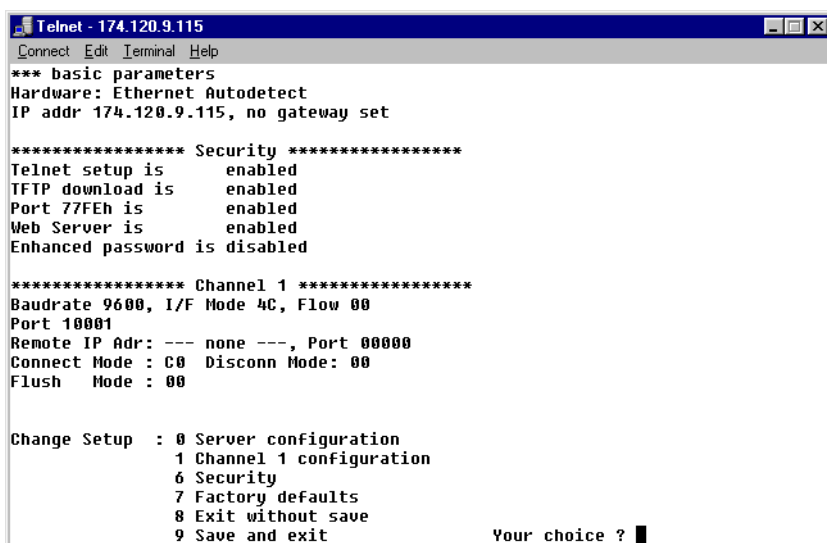

```
Telnet - 174.120.9.115
Connect Edit Terminal Help
*** basic parameters
Hardware: Ethernet Autodetect
IP addr 174.120.9.115, no gateway set

***** Security *****
Telnet setup is      enabled
TFTP download is    enabled
Port 77FEh is       enabled
Web Server is       enabled
Enhanced password is disabled

***** Channel 1 *****
Baudrate 9600, I/F Mode 4C, Flow 00
Port 10001
Remote IP Addr: --- none ---, Port 00000
Connect Mode : C0  Disconn Mode: 00
Flush  Mode : 00

Change Setup : 0 Server configuration
               1 Channel 1 configuration
               6 Security
               7 Factory defaults
               8 Exit without save
               9 Save and exit
Your choice ? █
```

Figure 32: Current LAN-505 Configuration

4. Press 7 <Enter> to reset the LAN-505 to all of its factory default parameters, including an IP Address of - 0 . 0 . 0 . 0.
5. Press 9 <Enter> to save this change and exit the Telnet program.
6. The “Connection to host lost” message appears again. Click the  box to clear the connection lost message, then close the Telnet window and close the DOS box. The IP address is now entered into the LAN-505’s configuration table.

## 4.3.2 Rebooting the Unit

To reboot the unit, use a thin rod (such as an opened paper clip) and press the reboot switch. The reboot switch is inside the unit and is accessed through a small hole in the case (see Figure 2 on page 5). Once pressed, wait 15 to 20 seconds for the unit to complete its reboot cycle.

# LAN-505 Ethernet Communication

## 4.4 Configure the LAN-505

LAN-505 configuration can be done either via a Telnet connection or a web browser connection (provided the LAN-505 has the appropriate firmware revision). The same configuration parameter values apply regardless of configuration method used. This section identifies the configuration parameter values that must be set for proper operation of the LAN-505 with *Doors* and then describes the two configuration processes. Use the configuration process that is easiest for you.

### 4.4.1 Required LAN-505 Configuration Parameters

The primary difference in how configuration parameters are handled between Telnet and web browsing is that several groups of related parameter values that are entered individually by web browsing are bundled together in a hex code and then entered when using Telnet. When entering configuration parameters, if an individual parameter is not called out in the instructions below, the factory default value should be left in place.

### 4.4.2 Configuration via Web Browser

*NOTE: Depending on the version of the Java installed on the computer, the web browser may appear different than shown here or may not appear at all. Check to make sure the current version of Java is installed.*

There are a number of critical parameters to set via web browser. These parameters are identified in this section. All other parameters should be left at their default values.

*NOTE: To configure the LAN-505 via web browser the browser **must** be Java enabled.*

1. From the DeviceInstaller page, click on the  button or open your web browser program and enter the IP address of the LAN-505 at the browser's "Open Page" command. The browser opens to the LAN-505 configuration screen (see Figure 33 on page 26).

# LAN-505 Ethernet Communication

Application Note

LAN-505

<b>Menu</b>	<b>Selected Channel : 1</b>
Unit Configuration	
Server Properties	
<b>Port Properties</b>	
Factory Settings1	
Factory Settings2	
Update Settings	
<b>Select Channel</b>	
<b>Channel1</b>	
Channel2	

<b>Serial Port Settings</b>	
Serial Protocol	RS232
Speed	9600
Character Size	8
Parity	None
Stopbit	1
Flow Control	None
<b>Connect Mode Settings</b>	
UDP Datagram Mode	Disable
UDP Datagram Type	
<a href="#">Change Address Table</a>	
Incoming Connection	Accept unconditional
Response	Nothing (quiet)
Startup	No Active Connection Startup
<b>Dedicated Connection</b>	
Remote IP Address	
Remote Port	
Local Port	10001
<b>Flush Mode Input Buffer (Line to Network)</b>	
On Active Connection	Disable
On Passive Connection	Disable
At Time To Disconnect	Disable
<b>Flush Mode Input Buffer (Network to Line)</b>	
On Active Connection	Disable
On Passive Connection	Disable
At Time To Disconnect	Disable
<b>Packing Algorithm</b>	
Packing Algorithm	Disable
Idle Time	Force Transmit 12ms
Trailing Characters	None
Send Immediate After Sendchars	Disable
Sendchar Define 2-Byte Sequence	Disable
Send Character 01	00
Send Character 02	00
<b>Additional Settings</b>	
Disconnect Mode	Ignore DTR
Check for CTRL-D To Disconnect	Disable
Port Password	Disable
Telnet Mode	Disable
Inactivity Timeout	Enable
Inactivity Timer	0:0
Port Password	

Figure 33: Web Browser LAN-505 Configuration Screen

# LAN-505 Ethernet Communication

- Click on the **Unit Configuration** button. The current unit configuration parameters are displayed (see Figure 34).

The screenshot shows a web interface for configuring a LAN-505 device. On the left is a 'Menu' with buttons for 'Unit Configuration', 'Server Properties', 'Port Properties', 'Factory Settings1', 'Factory Settings2', 'Update Settings', and 'Select Channel'. Under 'Select Channel', 'Channel1' is selected. The main area is titled 'Selected Channel : 1' and is divided into two sections: 'Server Configuration' and 'Port Configuration'. Each section contains several text input fields with their current values.

Selected Channel : 1	
<b>Server Configuration</b>	
Product	Universal Device Server
Model	Ethernet 2 Channel
Firmware Version	V5.50
Hardware Address	00-20-4A-80-A2-1E
IP Address	192.168.100.171
Subnet Mask	255.255.255.0
Gateway Address	0.0.0.0
<b>Port Configuration</b>	
Local Port Number	10001
Remote Port Number	
Serial Port Speed	9600
Flow Control	00
Interface Mode	4C
Connect Mode	C0
Disconnect Mode	00
Flush Mode	00
Pack Control	00
UDP Datagram Type	Not Supported By These Settings

Figure 34: Review Unit Configuration Screen

- The information in this screen is the same information presented via Telnet (see Figure 37 on page 30).
- Click on the **Server Properties** button. Server properties information is now displayed (see Figure 35).

The screenshot shows the 'Set Server Properties' screen. The 'Menu' on the left has 'Server Properties' selected. The main area is titled 'Server Properties' and contains four text input fields with their current values.

Server Properties	
IP Address	192.168.100.171
Subnet Mask	255.255.255.0
Gateway Address	0.0.0.0
Telnet Password	XXXX

Figure 35: Set Server Properties Screen

# LAN-505 Ethernet Communication

5. The IP address displayed must match the IP address of the LAN-505 being configured. None of the information in this screen should be changed.
6. Click on the  button to return to the Port Properties page (see Figure 33 on page 26).
7. Verify the following parameters are set to the specified values. If any of these parameters are incorrect, depending upon the field, you have two options for entering the appropriate configuration value.
  - select the correct value from a drop-down list of entries
  - type in the correct value

Verify the following values. Parameters not called out in the following list should be left at their default values.

#### Serial Port Settings to Verify

- Serial Protocol = RS232
- Speed = 9600
- Character Size = 8
- Parity = None
- Stop Bit = 1
- Flow Control = None

#### Connect Mode Settings to Verify

- Incoming Connection = Accept Unconditional
- Response = Nothing (Quiet)
- Startup = No Active Startup

#### Dedicated Connection Settings to Verify

- Local Port = 10001

#### Additional Settings

- Disconnect Mode = Ignore DTR

8. Once all these parameters have been verified/entered, click the  button. The parameter information is sent to the LAN-505 and the LAN-505 is rebooted to have these new values take effect. Once the LAN-505 has rebooted the unit configuration screen reappears (see Figure 34 on page 27). The LAN-505 is now ready for use.

# LAN-505 Ethernet Communication

## 4.4.3 Configuration via Telnet

There are only two critical parameters to set via Telnet (I/F Mode and Connect Mode); all other parameters should be left at their default values.

1. Open a DOS box and open a Telnet connection to Port 9999 on the LAN-505.

At the DOS prompt type the following to make the Port 9999 Telnet connection to the LAN-505:

```
- c:\>telnet <LAN-505 IP address> 9999 <Enter>
```

For example:

```
- c:\>telnet 174.120.9.115 9999 <Enter>
```

2. Press <Enter> to go into the LAN-505 Setup mode as soon as the Telnet sign-on screen appears. There is a two to three second delay in which you must press <Enter> before the Telnet session automatically closes. If the Telnet session closes before you enter Setup mode (if a “Connection to host lost” message appears), simply click the  box to clear the connection lost message and repeat the Telnet connection command in Step 1.
3. Once Telnet connects with the LAN-505 all current configuration information is displayed and the cursor is placed at the “Your choice” field (see Figure 32 on page 24).
4. Press 1 <Enter> to enter the Channel 1 Configuration values. The first configuration parameter is displayed (see Figure 36 on page 29).

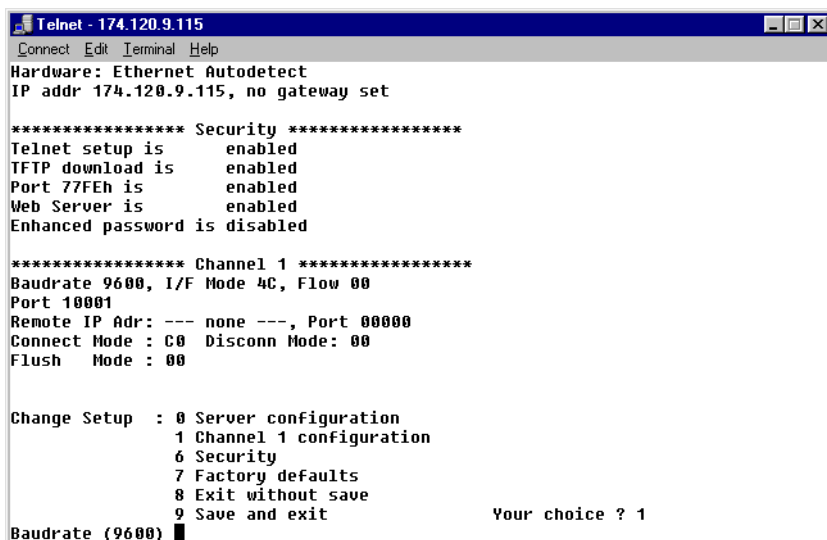

Figure 36: The First Channel 1 Configuration Parameters

# LAN-505 Ethernet Communication

5. If a configuration value needs to be changed, type the new value and the original value is overwritten. Every time <Enter> is pressed, the displayed configuration value is accepted and the next parameter is displayed.
6. Press <Enter> until the I/F Mode parameter is displayed. This value must be **4C** for proper communication between *Doors* and the LAN-505. If this value is not **4C**, type **4C** to overwrite the original value.
7. Press <Enter> until the Connect Mode parameter is displayed. This value must be **C0** for proper communication between *Doors* and the LAN-505. If this value is not **C0**, type **C0** to overwrite the original value.

Once all parameters have been displayed, the Change Setup menu appears. Verify the I/F Mode and Connect Mode parameters have been set to the correct values (see Figure 37 on page 30).

```

Telnet - 174.120.9.115
Connect Edit Terminal Help
1 Channel 1 configuration
6 Security
7 Factory defaults
8 Exit without save
9 Save and exit          Your choice ? 1

Baudrate (9600)
I/F Mode (4C) ?
Flow (00) ?
Port No (10001) ?
ConnectMode (C0) ?
Remote IP Address : (000) .(000) .(000) .(000)
Remote Port (00000) ?
DisConnMode (00) ?
FlushMode (00) ?
DisConnTime ( 00:00) ?:
SendChar 1 (00) ?
SendChar 2 (00) ?

Change Setup : 0 Server configuration
               1 Channel 1 configuration
               6 Security
               7 Factory defaults
               8 Exit without save
               9 Save and exit          Your choice ? 1
  
```

**Figure 37: Correct Channel 1 Configuration Parameters**

8. Press 9 <Enter> to save the assigned Channel 1 configuration parameters. A “Connection to host lost” message appears. Click the box to clear the connection lost message, then close the Telnet window and close the DOS box. The Channel 1 configuration parameters are now entered into the LAN-505’s configuration table.

*NOTE: The Remote Site Port Number and the Remote Site TCP/IP Address settings in the Doors program must be set to match the values of the LAN-505. These settings are found under the Setup System > Network Config tab in Doors. The default remote site port number for all LAN-505 units is 10001; the corresponding Remote Site Port Number in the Doors program must be set to 10001 to match the local port address of the LAN-505. The IP address for each LAN-505 is assigned by the LAN Administrator and is programmed into the unit using the instructions provided in Section 4.2 on page 6; the corresponding Remote Site TCP/IP Address in the Doors program must be set to match the IP address of the LAN-505.*

## 5.0 Using *Doors* Databases over a Network

Whenever a *Doors* database is opened (i.e. cardholder, time zone, access group, controller, door), a copy of that database is saved on the user's workstation. All changes made by the user are made to that local copy. The original database used by the *Doors* program on the file server

or shared folder does not receive these changes until the user clicks on the  button, physically overwriting the original database in the file server or shared folder with the newly edited information from the user's workstation. This is done to protect the original database from being affected if a user decides to cancel any changes being made.

What this means is that there can be database change conflicts if multiple users edit the same database simultaneously. There are two situations in which this can occur.

1. There are no notifications to indicate a database has been changed since the last time a user opened that database. If User-A and User-B both have the same database open and User-B saves changes to that database, User-A must close the database and then reopen it to see the changes made by User-B.
2. Suppose User-A and User-B have the same database open and both are making changes to that database. If User-A saves one set of changes and then User-B saves a different set of changes, the changes made by User-B (the last set of changes saved) will overwrite the changes made by User-A.

For these reasons, Keri Systems strongly recommends that only one user/workstation be allowed to view or modify a database at a time. Although multiple users can simultaneously work in the *Doors* program, only one workstation can communicate with the access control network at a time (using a direct connection or via remote control software). There is no way to simultaneously control an access control network from more than one workstation. This means that only one user at a time may be downloading information to the network, receiving information from a network, monitoring a network, or manually operating a network. When that user has completed work, that user must use the Net Disconnect command (the Operate > Net Disconnect pull-down menu option) to manually disconnect from the access control network and that user must close the *Doors* program to allow another user to gain access to the access control network.

# LAN-505 Ethernet Communication

---

## 6.0 Using the LAN-505 with Multiple PXL Networks

*Doors* can be used in “Sites” mode. Sites mode allows the user to manage multiple PXL-250 networks from one installation of *Doors*. The connection to a site is usually made via modem and each site has its own phone number. However, Sites mode can be done using LAN-505s in place of the modems. In this case, each site has its own IP address.

*NOTE: If you decide to use LAN-505s to communicate with multiple sites, **all** sites must be able to support 10/100 mps transfers. You cannot have some sites communicate via LAN and other sites communicate via modem, and you cannot configure the system for switching between the two communication methods.*

The complete process for configuring *Doors* for operation in TCP/IP Sites mode is described in the *Doors Users Guide – Multiple Site Control Section* (P/N 01821-002). Please refer to this document for multiple site TCP/IP configuration information.

## 7.0 Ethernet Troubleshooting Guide

This section provides some basic troubleshooting information should you have trouble connecting to a LAN-505.

*NOTE: This section assumes you have a working knowledge of computer networks. For the troubleshooting process, you should consult with the system or network administrator.*

### 7.1 Verify the TCP/IP Settings in the *Doors* Program

1. Check the IP address and port number (see Figure 38).
  - The IP address in the *Doors* program should match the IP address programmed into the LAN-505 unit.
  - By default, the Server's Ethernet Port Number is set to 10021 and should not be changed unless it conflicts with another device on the host workstation. Please consult your system or network administrator.
  - By default, the Remote Site Port Number is set to 3001. This value **must be changed** to 10001. It should not be changed unless instructed to do so by the system or network administrator.

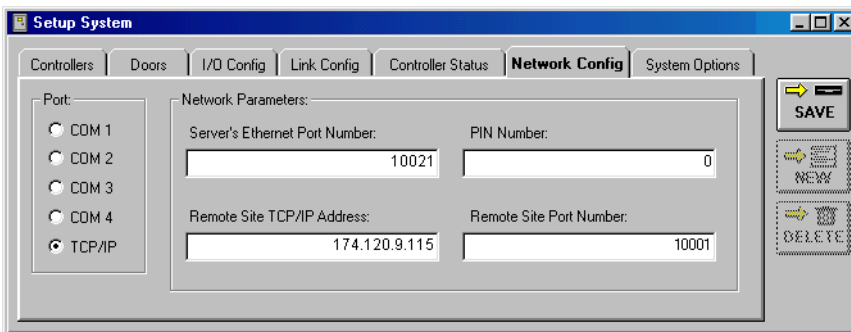



Figure 38: *Doors* TCP/IP Settings

2. Once all the information has been verified as being correct, click on the  button.
3. You may need to close and then re-open the *Doors* program for the changes to take place.

# LAN-505 Ethernet Communication

## 7.2 Verify the LAN-505 Settings

1. There are two ways to verify the LAN-505 settings. Refer to the Lantronix Reference Manual for detailed instructions on using each method.

- Telnet - channel 1 configuration commands
- HTTP web browser utility - server properties, port properties

Review the displayed configuration for the LAN-505. Verify the LAN-505 settings per the instructions in Section 4.4 on page 25.

## 7.3 Verify the LAN-505 is Online

1. Ping the IP address of the LAN-505. If the ping fails, that means a communication connection cannot be made. Possible reasons are:

- There is no power to the LAN-505 unit.
- The IP address was not programmed properly.
- Another device on the network has that same IP address.
- The workstation has not been granted access to that segment of the network.

Contact the system or network administrator to resolve these issues.

## 7.4 Contact Lantronix Technical Support

If the LAN device is set properly and the device pings successfully, but communication is still not happening, check the PXL unit to make sure the pins are removed from JP6 and JP7 (see Figure 2 on page 5 for location of the pins).

1. If you continue to have problems connecting, detailed information is provided by Lantronix. Please refer to the Lantronix Support web site at the following URL.

<http://www.lantronix.com/support/>

**Table 1: Lantronix Part Description**

Keri Systems, Inc.	Lantronix Equivalent
LAN-505	Micro 100