

# RPB-200: RF Receiver

## The RPB-200 RF Receiver

The RPB-200 can be used with the PXL-250W or the PXL-100 with an OB-7. It provides a range of up to 50 feet when used in conjunction with a standard hard wire antenna and either mini or standard transmitter cards. There are no switches or jumpers to set; simply install the enclosure, make the wiring connections, and the unit is ready for use.

*NOTE: This document provides the instructions for connecting the RPB-200 to the PXL-250W Tiger Controller or the PXL-100 Smart Controller. Please refer to the installation instructions provided by the RPB-200's manufacturer for instructions on enclosure mounting and for providing power to the RPB-200.*

## 1.0 Dimensions

### 1.1 Enclosure

- 5.00 inches High x 5.00 inches Wide x 2.00 inches Deep
- 12.7 cm High x 12.7 cm Wide x 5.1 cm Deep

### 1.2 Antenna

- 11 inches High
- 28 cm High

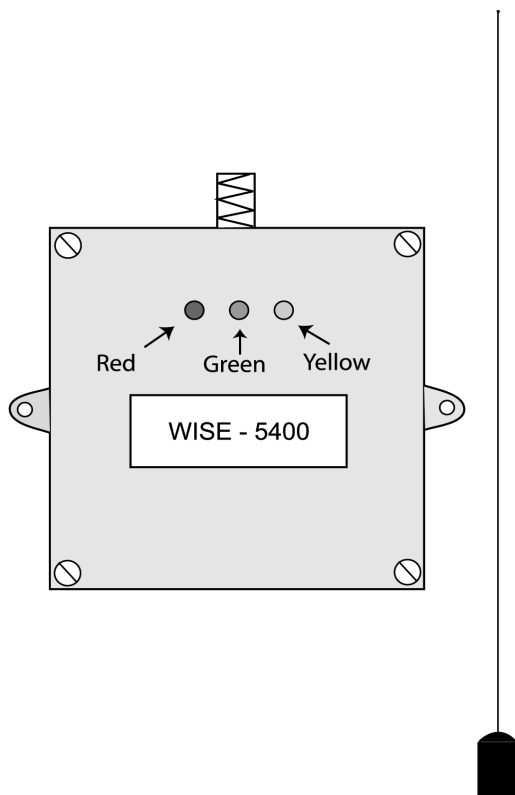

Figure 1: RPB-200 RF Receiver

# RPB-200: RF Receiver

## 2.0 Connections

The connection between the PXL controller and the RPB-200 is made through a 7 conductor, shielded, stranded, AWG 24 wire cable (such as Belden 9537 or a larger gauge).

Before running a cable to the RPB-200 you must drill a 1/4 inch diameter hole in the case of the RPB-200 to accommodate the cable. After the cable has been connected to the RPB-200, the cable/hole can be sealed with a silicone/RTV type sealer.

### 2.1 Connecting to the RPB-200

The cable connects to the terminal strip on the RF receiver board, pins 1 through 8 (excluding pins 3 and 6). The cable shield is not connected at the RPB-200.

### 2.2 Connecting to the PXL-250W

For an "A" reader connection, the cable connects to TB5 pins 1 through 7 (excluding pin 2). For a "B" reader connection, the cable connects to TB6 pins 1 through 7 (excluding pin 2).

**RPB-200 Cable Connections**

Pin #	Function	Wire Color
1	Ground	Black
—	—	—
2	Power	Red
3	no connection	—
4	Red LED	Brown
5	Green LED	Orange
6	Yellow LED	—
7	Data 1	White
8	Data 0	Green

**Connecting to the PXL-250W at TB5/TB6**

Pin #	Function	Wire Color
4	Ground	Black
4	Shield	Silver
3	12V Power	Red
2	not used	—
6	Red LED	Brown
5	Green LED	Orange
—	—	—
7	Data 1	White
1	Data 0	Green

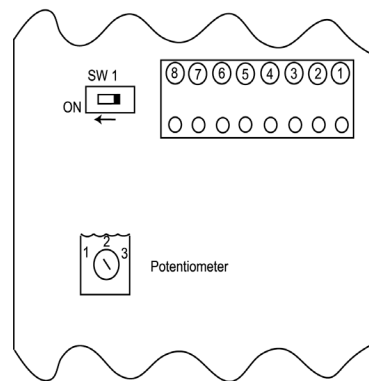

**Figure 2: RPB-200 Connections**

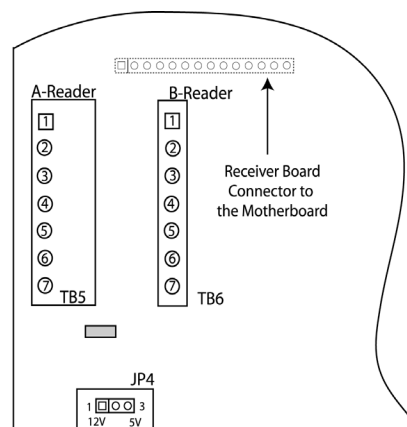

**Figure 3: PXL-250W Connections**

# RPB-200: RF Receiver

## 2.3 Connecting to the Design 5 PXL-100

For the RPB-200 to work with a PXL-100, the PXL-100 must have an OB-7 Wiegand Interface option board installed. The cable connects to J1 on the OB-7, pins 1 and 2; and J2 on the OB-7, pins 1, 2, 5, and 6.

### 2.3.1 Connecting to the PXL-100 @ OB-7, J1

Pin #	OB-7 PCB Marking	Function	Wire Color
1	0V	Ground	Black
1	0V	Shield	Silver
2	12V	12V Power	Red
3	–	–	–
4	–	–	–
5	–	–	–
6	–	–	–

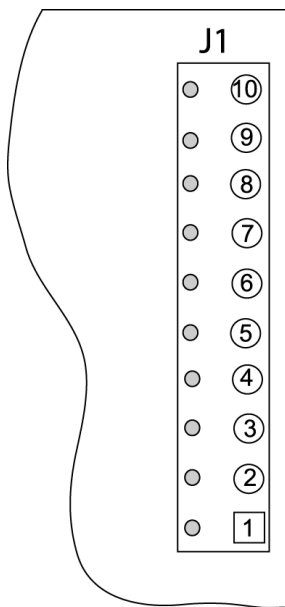
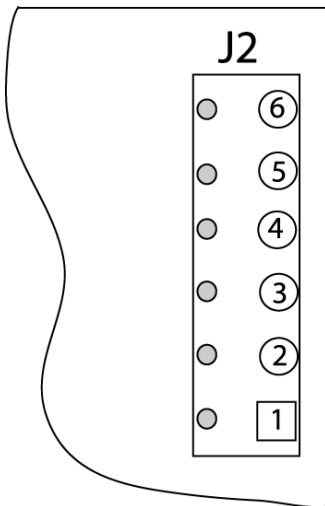

Figure 4: PXL-100/J1 Connections on the OB-7

# RPB-200: RF Receiver

## 2.3.2 Connecting to the PXL-100 @ OB-7, J2

Pin #	OB-7 PCB Marking	Function	Wire Color
1	LED	Red LED	Brown
2	BEEPER	not used	–
3	–	–	–
4	–	–	–
4	–	–	–
5	M IP B	Data 1	White
6	M IP A	Data 0	Green



**Figure 5: PXL-100/OB-7 Connections**

*NOTE: Please contact customer support at Keri Systems for information regarding connecting an RPB-200 to a Design 4 PXL-100. A Design 4 PXL-100 can be identified by the location of its power connection made at the middle of the left edge of the printed circuit board.*

# RPB-200: RF Receiver

## 3.0 Testing and Changing Receiver Range

### 3.1 Testing Receiver Range

You may want to test the receiver range.

1. Switch SW1 on the RPB-200 to the "ON" position (see Figure 2 on page 2).
2. Activate a transmitter card within range of the receiver.
3. If the receiver is functioning properly and the transmitter card has been activated within range, the yellow LED on the receiver will flash once.
4. Repeat the process moving away from the receiver. When the yellow LED does not flash, you have moved outside of the receiver's range.

### 3.2 Changing Receiver Range

If the receiver range is set at a distance either too near or too far, you may change the distance.

1. To increase the receiver range distance, turn the potentiometer clockwise (see Figure 2 on page 2).
2. To decrease the receiver range distance, turn the potentiometer counter-clockwise (see Figure 2 on page 2).
3. Repeat steps 1-3 in Testing Receiver Range, until you have found the range that will work best for you.

*NOTE: When you have the receiver range set at the distance you want, be sure to switch SW1 back to the OFF position.*

## 4.0 Installation Verification

If desired, following installation, receiver operation can be verified within the Doors program. Perform the following steps to verify receiver operation.

1. Enter the Doors program.
2. Click on the Operate ⇒ Start Monitor pull-down menu option.
3. Click on the Monitor button.
4. Click on the View Window 1 button (its default definition is to show all events that occur).
5. Activate a transmitter card within the range of the receiver.
6. An "Unknown Key" message will appear in the monitor view window, verifying the key was read and its data was transferred to the controller.

# RPB-200: RF Receiver

## 5.0 Enrollment Procedure

Once installation is verified and the receiver range has been set, you may begin enrolling transmitter cards. Enrolling transmitter cards is accomplished the same as enrolling cards (see Setup Cards in the Doors32 Users Guide – P/N 01821-002).

- When presenting to the reader for card enrollment, the receiver is used as the main reader. To present the transmitter card for enrolling, activate the transmitter card within range of the receiver.
- The card number, to be used for block enrolling, may be found on the label of the transmitter card. An example of where the information may be located on the transmitter card is shown in Figure 6.

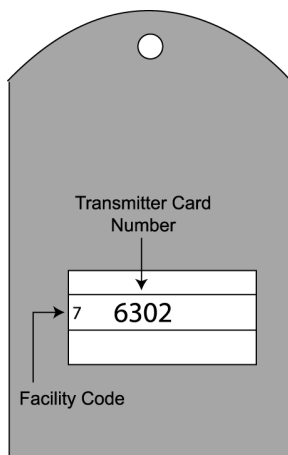

**Figure 6: Transmitter Card Number**

# RPB-200: RF Receiver

## 6.0 Troubleshooting the Receiver Installation

Problem	Probable Cause	Corrective Action
The controller does not recognize the RPB-200.	1. One or more of the receiver's wiring connections are incorrect.	<ul style="list-style-type: none"> <li>Power down the controller and the receiver and verify the wiring connections are correct per the instructions provided in the Connections section on page 2.</li> </ul>
	2. Insufficient power is being provided to the RPB-200.	<ul style="list-style-type: none"> <li>Verify the power supply voltage and wiring for the RPB-200 is correct (refer to the RPB manual provided with the RPB unit).</li> </ul>
	3. The battery in the transmitter card is weak or dead.	<ul style="list-style-type: none"> <li>Verify battery strength or replace the battery.</li> </ul>
	4. PXL-100 ONLY – JP9 on the OB-7 is installed.	<ul style="list-style-type: none"> <li>Refer to the OB-7 Quick Start Guide and verify there is not a jumper across JP9.</li> </ul>
The RPB-200 is recognizing the transmitter card, but not showing up on the software.	1. Data 0 and Data 1 are reversed.	<ul style="list-style-type: none"> <li>Switch Data 0 and Data 1 positions.</li> </ul>
The RPB-200 has a short receive range.	1. The RPB-200 range adjustment potentiometer should be increased.	<ul style="list-style-type: none"> <li>Refer to the Receiver Installation sheet provided by the Receiver's manufacturer for range adjustment instructions.</li> </ul>
	2. The antenna is shielded by metal.	<ul style="list-style-type: none"> <li>Relocate the enclosure or the antenna away from metal surfaces.</li> </ul>
	3. The battery in the transmitter card is weak or dead.	<ul style="list-style-type: none"> <li>Verify battery strength or replace the battery.</li> </ul>

# *RPB-200: RF Receiver*

---

**Quick Start Guide**

**RPB-200**

This page is intentionally left blank.