

SB-293 Satellite Board

This quick start guide is made up of a specification sheet, basic installation drawings and information, and short descriptions of key terms and concepts. For comprehensive information regarding the SB-293 Satellite Board, please refer to the Technical Reference Manual (P/N 01836-004).

1.0 Specifications

Unit Dimensions

- PXL-250 controller PCB with an SB-293 Satellite Board
 - 7.25 inches high by 6.00 inches wide by 1.75 inches deep, including wiring connectors
 - (18.45 cm by 15.25 cm by 4.45 cm)
- PXL-250 controller PCB with an SB-293 Satellite Board and an LCD-1 Alpha/Numeric Display
 - 8.10 inches high by 6.00 inches wide by 1.75 inches deep, including wiring connectors
 - (20.60 cm by 15.25 cm by 4.45 cm)
- Enclosure
 - 9.70 inches high by 8.20 inches wide by 2.60 inches deep
 - (24.65 cm by 20.85 cm by 6.60 cm)

Operating Temperature/Humidity Range

- 0°F to 140°F (-18°C to 60°C)
- 0% to 90% Relative Humidity, non-condensing

Controller with Satellite Board Power Requirements

- 12 VDC @ 1 Amp

Current Draw

- maximum current draw 270 mA for a controller plus reader current draw (refer to Table 1 for Reader current draw)
- 120 mA max for a PXL-250 Controller
- 150 mA max for an SB-293 Satellite Board

Table 1: Reader Current Draw

	Reader Type				
	MS-3000	MS-4000	MS-5000	MS-7000	MS-9000
Current Draw	50 mA	50 mA	100 mA	200 mA	200 mA

Output Relay Contact Rating

- 1 Amp @ 24 VDC

Input Device Configuration

- Door Sense normally closed
- Request to Exit normally open
- Global Unlock normally open, or
- Auxiliary RTE A-Door normally open

SB-293 Satellite Board

2.0 Cable Requirements

- two conductor, stranded, AWG 22 or a larger gauge for all input/output connections

NOTE: The Lock Output relay may require a heavier gauge of wire depending upon the current demands of the lock and the length of the lock wiring run.

3.0 When Installing Satellite Boards

DO

- route cables in accessible areas for ease of maintenance
- add transient suppression across electric devices attached to a satellite board output
- use an isolation relay (Keri Systems P/N IRP-1) if attaching to a parking gate, a turnstile, or any application using a large electric motor
- for a single door application, install the door's reader to the TB-5, "A" reader connection on the controller
- for a two door application, install the primary door's reader to the TB-5, "A" reader connection on the controller and install the secondary door's reader to the TB-6, "B" reader connection on the controller

DO NOT

- stretch or over-tension cables
- route cables over sharp objects
- let cables or wires get tangled

4.0 Jumper Setting

JP12 - Configures the Satellite Board (see Figure 1)

- Jumper across JP12, pins 1 and 2, configures the Satellite board for general purpose inputs and outputs.
- NO jumper across JP12 configures the Satellite board for second door control with additional inputs and outputs. When the Satellite board is configured for second door control, the primary door must be connected to the "A" reader (TB-5 on the PXL-250 controller board) and the secondary door must be connected to the "B" reader (TB-6 on the controller board).

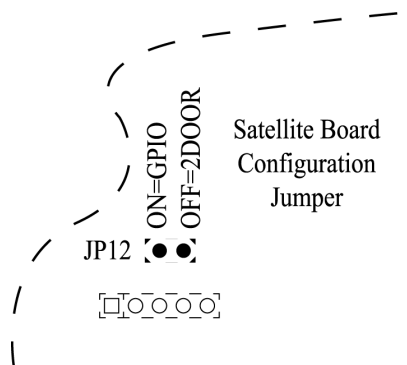

Figure 1: Setting JP12

SB-293 Satellite Board

5.0 Board Installation

Perform the following steps to install an SB-293 Satellite board on a PXL-250 controller (see Figure 2).

1. Turn the controller's power OFF.
2. Line up the upper left-hand corner of the Satellite PCB with the controller PCB.
3. Line up the stand-offs in the top two corners of the Satellite PCB with corresponding mounting holes in the controller PCB (see Figure 2).
4. Align the Satellite Board to Motherboard connector pins (J2 and J3).
5. Gently press the two boards together with each stand-off into its mounting hole and with the connector pins meshing together.
6. Turn the controller's power ON.

If the J2 to P2 connector pins have been meshed together properly the LED on the SB-293 turns green (see Figure 4 on page 4).

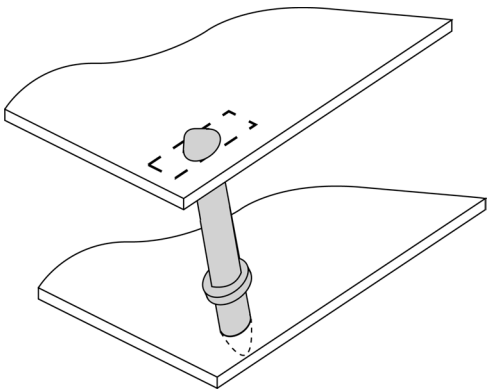

Figure 2: Stand-off Installation

6.0 Connecting Wires - Removing a Terminal Block

Strip away 1/4 inch of insulation and place the wire in the appropriate slot.

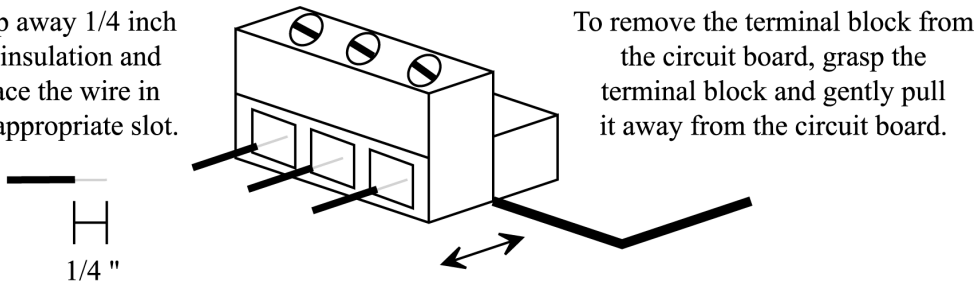

Figure 3: Connecting Wires to Terminal Blocks

SB-293 Satellite Board

7.0 The SB-293 Satellite Board Wiring Connections

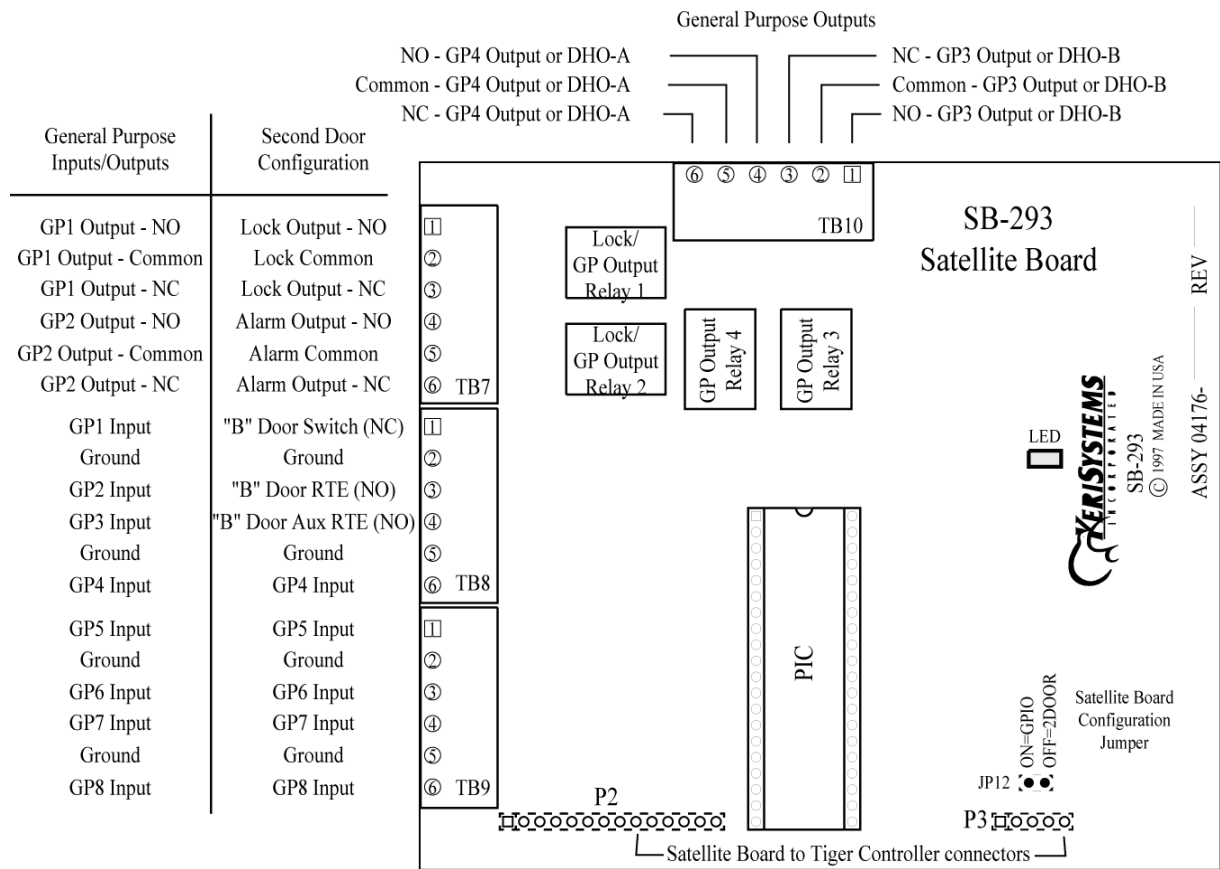

Figure 4: The SB-293 Satellite Board

SB-293 Satellite Board

7.1 Two Door Configuration Connections

This configuration assumes JP12 is **OFF**, configuring the Satellite board for Two-Door control.

7.1.1 Output Relays

Please refer to Figure 4 on page 4 for output relay wiring locations.

Table 2: Output Relays

TB-7/TB-10 Relay Outputs	Description
TB-7 – Pin 1	lock output – normally open line
TB-7 – Pin 2	common/ground
TB-7 – Pin 3	lock output – normally closed line
TB-7 – Pin 4	alarm output – normally open line
TB-7 – Pin 5	common/ground
TB-7 – Pin 6	alarm output – normally closed line
TB-10 – Pin 1	GPO 3/DHO-B ^a – normally open line
TB-10 – Pin 2	common/ground
TB-10 – Pin 3	GPO 3/DHO-B ^a – normally closed line
TB-10 – Pin 4	GPO 4/DHO-A ^a – normally open line
TB-10 – Pin 5	common/ground
TB-10 – Pin 6	GPO 4/DHO-A ^a – normally closed line

- a. The Door Held Open (DHO) alarm feature is not available in 16-bit *Doors* software applications.

See page 6 for a sample Fail-Safe Door Lock Output Relay drawing.

See page 6 for a sample Fail-Secure Door Lock Output Relay drawing.

See page 6 for a sample Alarm Output Relay drawing.

See page 7 for a sample Door Held Open – A-Door Relay drawing.

See page 7 for a sample Door Held Open – B-Door Relay drawing.

See page 8 for a sample General Purpose Normally-Open Output Relay drawing.

See page 8 for a sample General Purpose Normally-Closed Output Relay drawing.

SB-293 Satellite Board

7.1.1.1 Fail-Safe Door Lock Output Relay

In a fail-safe application, if the power fails, the door is unlocked (see page 16 for information about fail-safe lock applications).

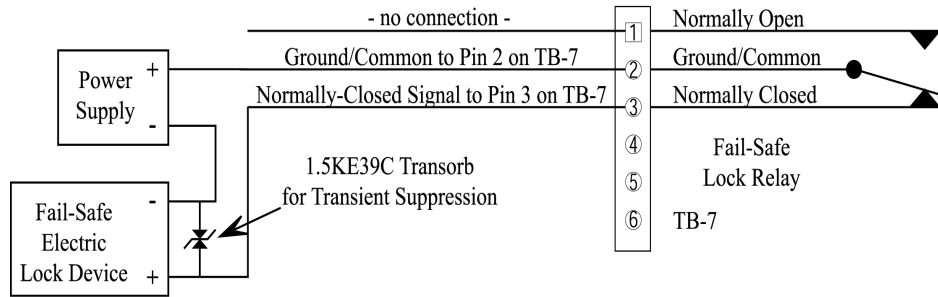

Figure 5: Fail-Safe Door Lock Output Relay

7.1.1.2 Fail-Secure Door Lock Output Relay

In a fail-secure application, if the power fails, the door is locked (see page 16 for information about fail-secure lock applications).

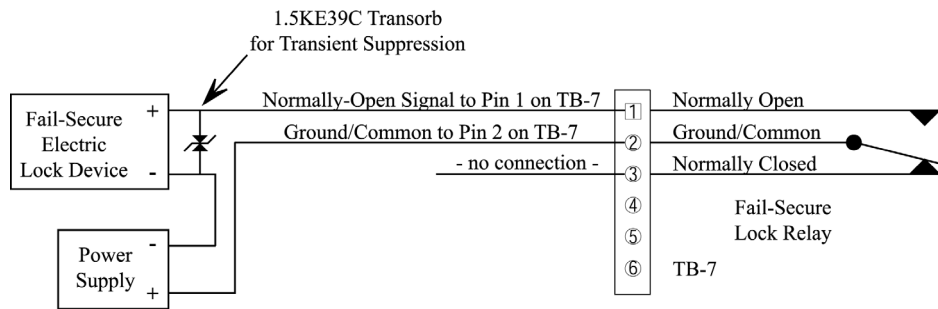

Figure 6: Fail-Secure Door Lock Output Relay

7.1.1.3 Alarm Output Relay

An alarm condition on the controller closes the normally open line, sounding an alarm.

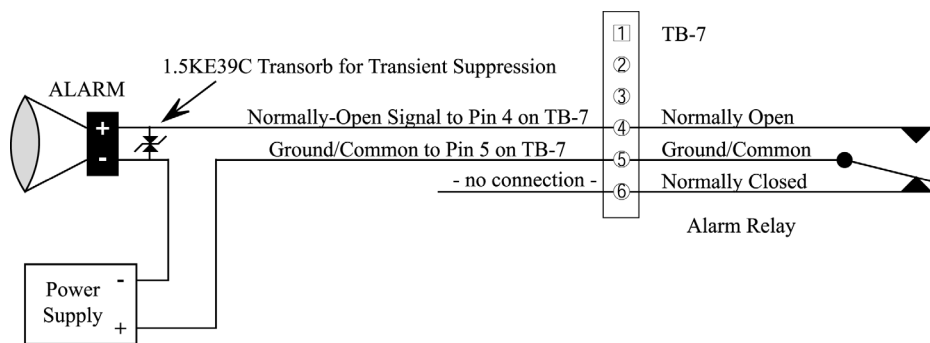

Figure 7: Alarm Output Relay

SB-293 Satellite Board

7.1.1.4 Door Held Open Alarm Output Relay

These instructions apply if the enhanced alarm out annunciation feature in the *Doors* software has configured these outputs for door held open annunciation. The DHO alarm feature is not available in 16-bit *Doors* software applications. If you are not using the DHO feature, skip to the General-Purpose Outputs sections on page 8.

An alarm condition on the controller closes the normally open line, sounding an alarm. The following figure is for the A-door.

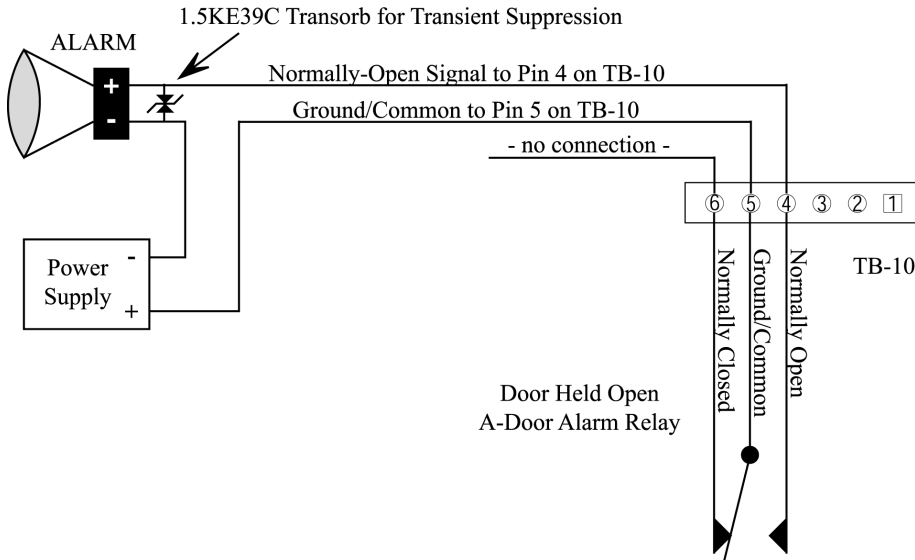

Figure 8: Door Held Open Alarm – A-Door

The following figure is for the B-door.

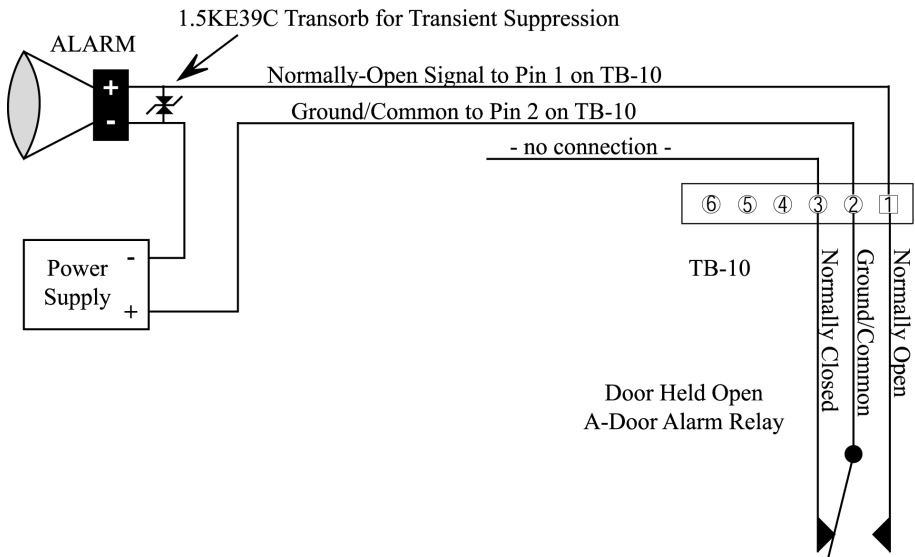

Figure 9: Door Held Open Alarm – B-Door

SB-293 Satellite Board

7.1.1.5 General Purpose Outputs - Normally Open Relay Connection

In the following application, an event causes programming in the controller to close the normally-open line, temporarily turning on a video camera.

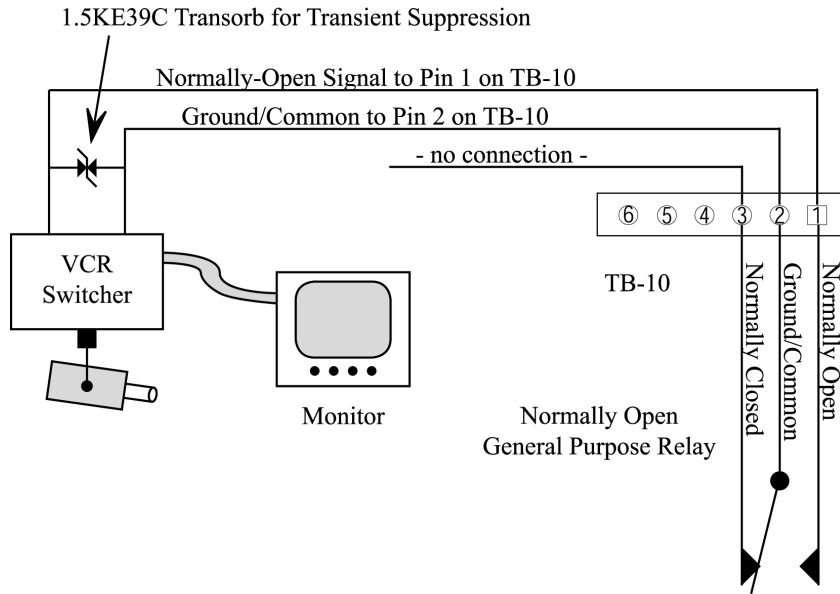

Figure 10: General Purpose Output – Normally Open Relay

7.1.1.6 General Purpose Outputs - Normally Closed Relay Connection

In the following application, an event causes programming in the controller to open the normally-closed line, temporarily turning off a sensor device.

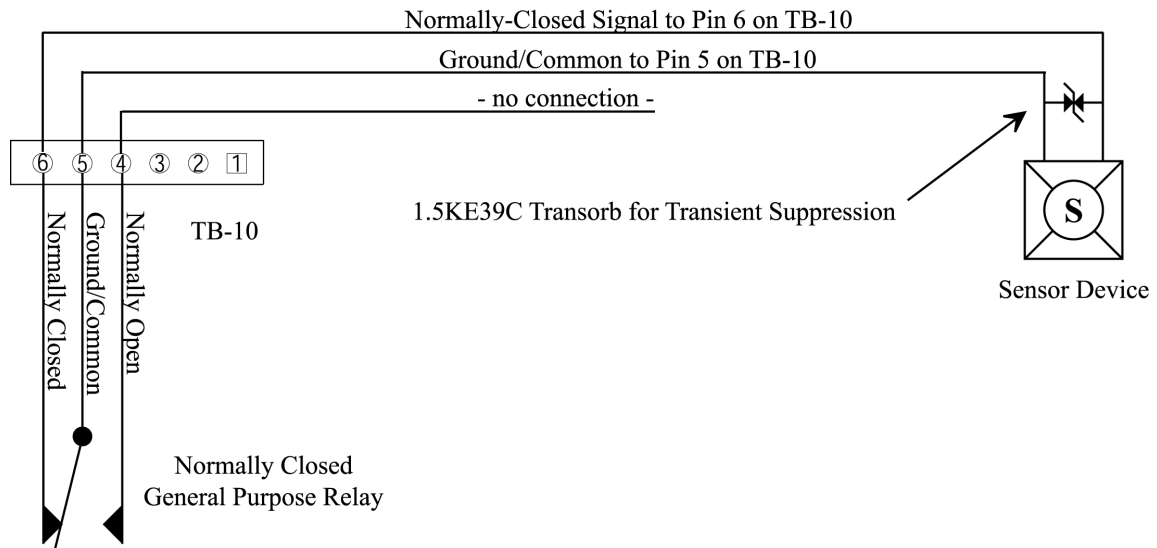

Figure 11: General Purpose Output – Normally Closed Relay

SB-293 Satellite Board

7.1.2 Inputs Table

Please refer to Figure 4 on page 4 for output relay wiring locations.

Table 3: Inputs

TB-8/TB-9 Inputs	Description
TB-8 – Pin 1	door status switch input – normally closed
TB-8 – Pin 2	common/ground
TB-8 – Pin 3	RTE input – normally open
TB-8 – Pin 4	GPI 3 input ^a / AUX RTE-B ^b input – normally open
TB-8 – Pin 5	common/ground
TB-8 – Pin 6	GPI 4 input ^a
TB-9 – Pin 1	GPI 5 input ^a
TB-9 – Pin 2	common/ground
TB-9 – Pin 3	GPI 6 input ^a
TB-9 – Pin 4	GPI 7 input ^a
TB-9 – Pin 5	common/ground
TB-9 – Pin 6	GPI 8 input ^a

- a. General Purpose inputs can accept either a normally closed or normally open signal. The type of signal depends upon the type of input device. The *Doors* software is then programmed to accept that type of input.
- b. The Auxiliary RTE input feature is not available in 16-bit *Doors* software applications.

- See page 10 for a sample Door Status Switch Input drawing.
- See page 10 for a sample Request to Exit (RTE) Input drawing.
- See page 10 for a sample Auxiliary RTE Input drawing.
- See page 11 for a sample General Purpose Input drawing.

SB-293 Satellite Board

7.1.2.1 Door Status Switch Input

A door status switch opens and closes as the door is opened and closed.

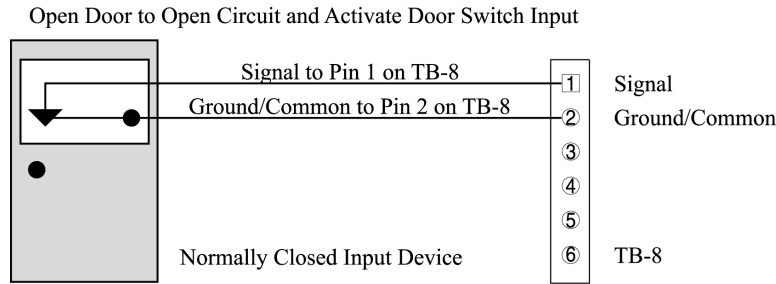

Figure 12: Door Status Switch Input

NOTE: If a door switch is not installed, a jumper must be installed across pins 1 and 2 of TB8 to prevent a continuous door open alarm from being reported by the controller.

7.1.2.2 Request to Exit (RTE) Input

In an RTE circuit a user presses a switch (completing the circuit) to inform the controller that the user wishes to exit through the door associated with that controller.

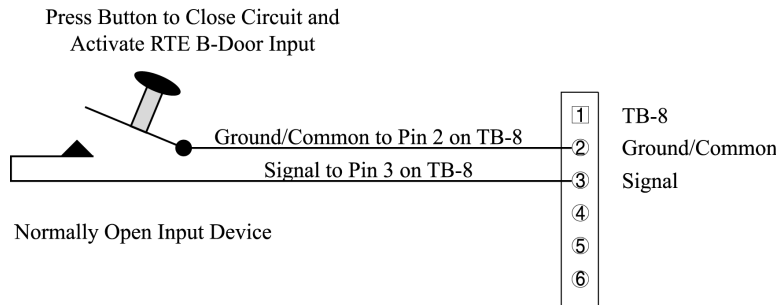

Figure 13: Request to Exit Input

7.1.2.3 Auxiliary Request to Exit (RTE) Input

In an auxiliary RTE circuit a user presses a switch (completing the circuit) to inform the controller that the user wishes to exit through the door associated with that controller. The Auxiliary RTE input feature is not available in 16-bit *Doors* software applications.

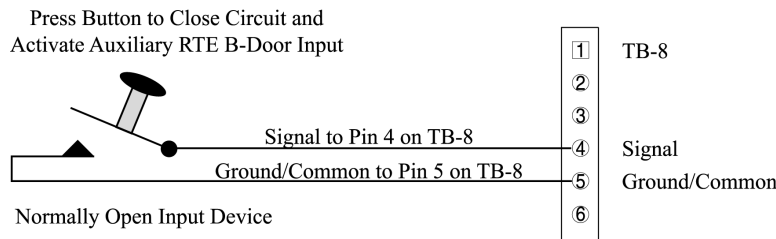

Figure 14: Auxiliary Request to Exit Input

SB-293 Satellite Board

7.1.2.4 General Purpose Inputs

For the application in Figure 15, a circuit is opened to create an input event at the controller.

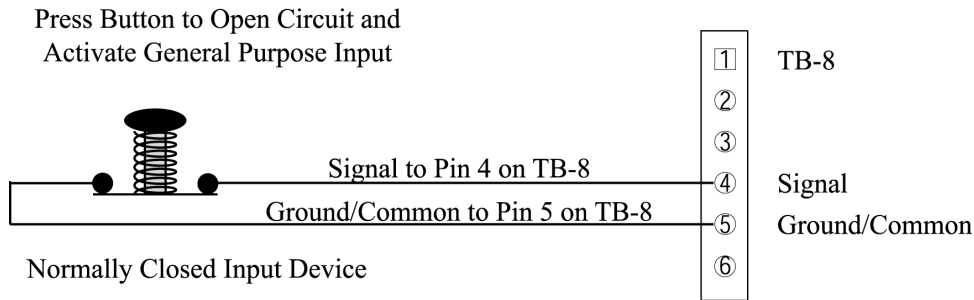

Figure 15: General Purpose Input

For the application in Figure 16, the motion detector senses motion and closes a circuit to create an input event at the controller.

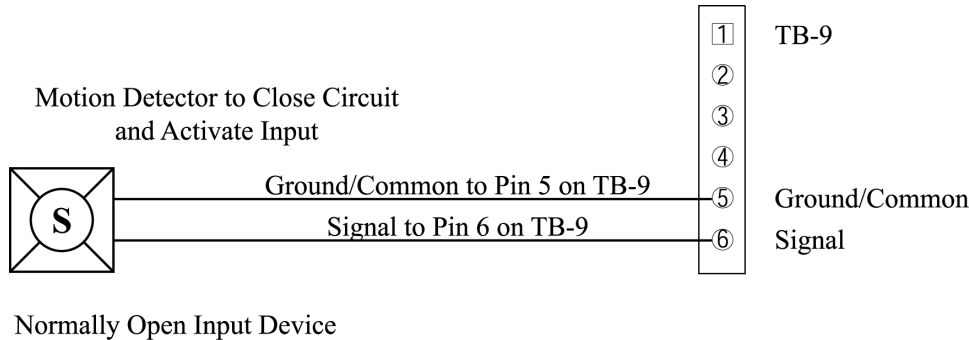

Figure 16: General Purpose Input

SB-293 Satellite Board

7.2 General Purpose Input/Output Configuration Connections for *Doors*

This configuration assumes JP12 is ON configuring the Satellite board for general purpose inputs and outputs.

7.2.1 Output Relays Table

Please refer to Figure 4 on page 4 for output relay wiring locations.

Table 4: Output Relays

TB-7/TB-10 Relay Outputs	Description
TB-7 – Pin 1	GPO 1 – normally open line
TB-7 – Pin 2	common/ground
TB-7 – Pin 3	GPO 1 – normally closed line
TB-7 – Pin 4	GPO 2 – normally open line
TB-7 – Pin 5	common/ground
TB-7 – Pin 6	GPO 2 – normally closed line
TB-10 – Pin 1	GPO 3 – normally open line
TB-10 – Pin 2	common/ground
TB-10 – Pin 3	GPO 3 – normally closed line
TB-10 – Pin 4	GPO 4 – normally open line
TB-10 – Pin 5	common/ground
TB-10 – Pin 6	GPO 4 – normally closed line

- See page 13 for a sample General Purpose Normally-Closed Relay drawing.
- See page 13 for a sample General Purpose Normally-Open Relay drawing.

SB-293 Satellite Board

7.2.1.1 General Purpose Outputs - Normally Closed Relay Connection

In the following application, an event causes programming in the controller to open the normally-closed line, temporarily turning off a sensor device.

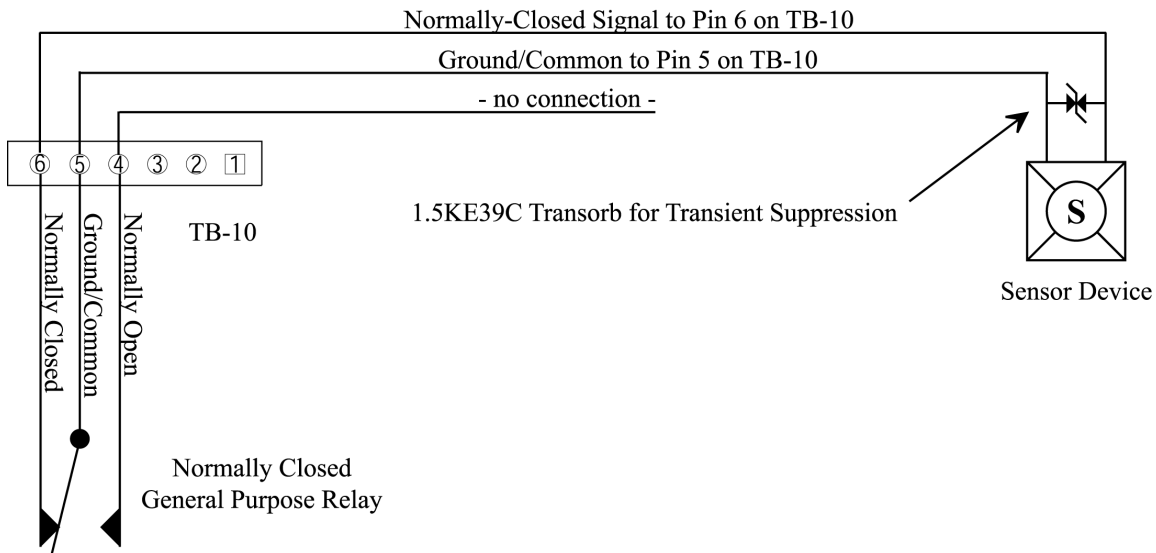

Figure 17: General Purpose Output – Normally Closed Relay

7.2.1.2 General Purpose Outputs - Normally Open Relay Connection

In the following application, an event causes programming in the controller to close the normally-open line, temporarily turning on a video camera.

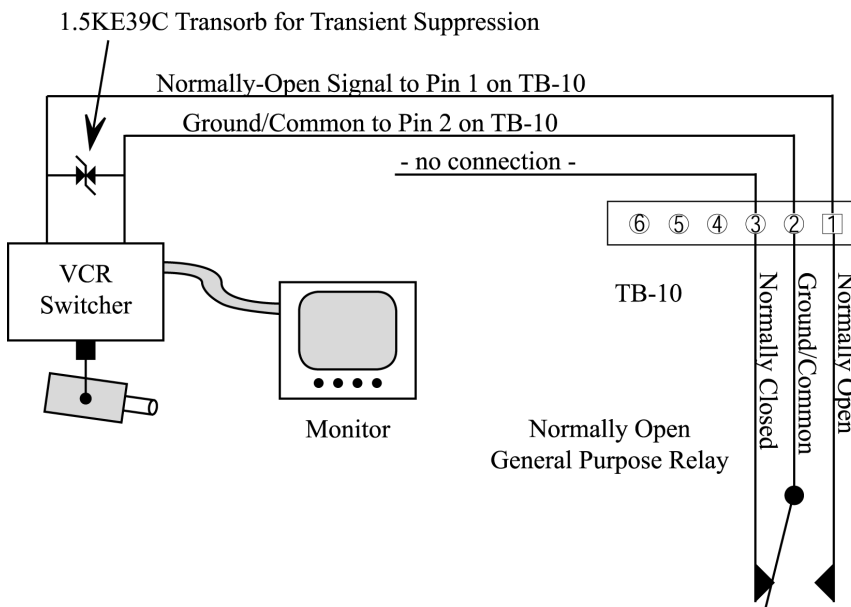

Figure 18: General Purpose Output – Normally Open Relay

SB-293 Satellite Board

7.2.2 Inputs Table

Please refer to Figure 4 on page 4 for input wiring locations.

Table 5: Inputs Table

TB-8/TB-9 Inputs	Description
TB-8 – Pin 1	GPI 1 ^a
TB-8 – Pin 2	common/ground
TB-8 – Pin 3	GPI 2 ^a
TB-8 – Pin 4	GPI 3 ^a
TB-8 – Pin 5	common/ground
TB-8 – Pin 6	GPI 4 ^a
TB-9 – Pin 1	GPI 5 ^a
TB-9 – Pin 2	common/ground
TB-9 – Pin 3	GPI 6 ^a
TB-9 – Pin 4	GPI 7 ^a
TB-9 – Pin 5	common/ground
TB-9 – Pin 6	GPI 8 ^a

a. General Purpose inputs can accept either a normally closed or normally open signal. The type of signal depends upon the type of input device. The *Doors* software is then programmed to accept that type of input.

- See page 15 for a sample General Purpose Input drawing.

SB-293 Satellite Board

7.2.3 General Purpose Inputs

For the application in Figure 19, a circuit is opened to create an input event at the controller.

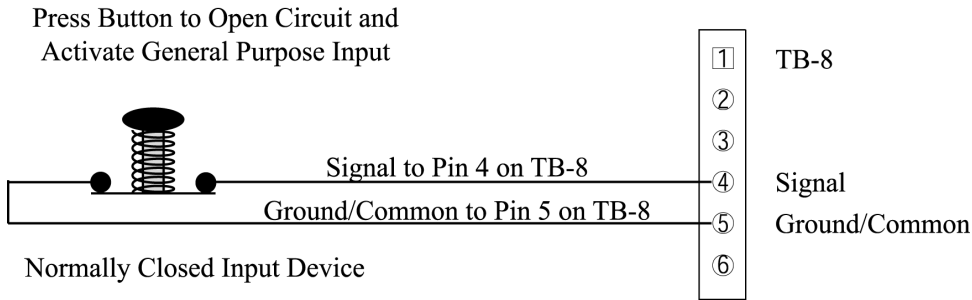

Figure 19: General Purpose Input

For the application in Figure 20, the motion detector senses motion and closes a circuit to create an input event at the controller.

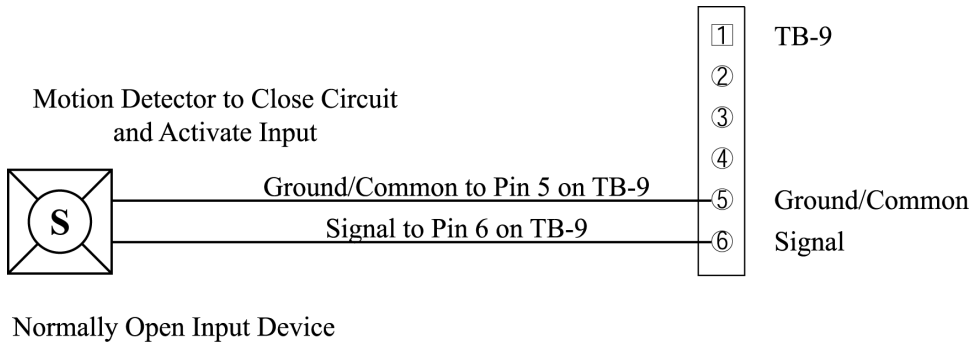

Figure 20: General Purpose Input

SB-293 Satellite Board

8.0 General Information on Inputs

A controller input detects a state change generated by a device outside the controller that may prompt a response from the controller. Input devices that generate a state change may be normally-closed or normally-open. This section provides a brief description of normally-closed versus normally-open inputs.

8.1 Normally-Closed

A normally-closed input device continually keeps a circuit active or complete. A state change is generated when the normally-closed input device is forced open, breaking the circuit. In an access control system, a door switch is a typical example of a normally-closed device. While the door remains closed, the switch remains closed. When someone opens the door, the door switch is opened, breaking the circuit and generating a state change. The controller then responds to the state change and generates an output (such as sounding an alarm if the door is a secure door).

8.2 Normally-Open

A normally-open input device continually leaves a circuit open, or incomplete. A state change is generated when the normally-open input device is forced closed, completing the circuit. In an access control system, a request-to-exit (RTE) button is a typical example of a normally open device. In an access control installation, an RTE button is located on the secure side of a door. While there is no one there pressing the button, the switch remains open. When someone desires to exit through a secure door, they press the RTE button, closing the circuit and generating a state change. The controller then responds to this state change and generates an output (such as unlocking the door to allow egress).

9.0 General Information on Safety versus Security with Door Locks

When installing a door lock there are two things to consider: safety versus security, or should the door be "fail-safe" or "fail-secure."

9.1 Fail-Safe Door Lock

Fail-safe means that if the power should fail at a door (perhaps due to a power outage or equipment failure), the door will automatically unlock allowing entrance or egress. Power is required to keep the door locked. A fail-safe door ensures people will be able to enter and exit a secured area through that door in the case of an emergency. A typical fail-safe application may use a magnetic lock. In this application, the controller energizes the lock relay, causing the lock relay to change its state. In its new state the normally-closed circuit is opened breaking the power to the magnetic lock and allowing the door to be opened.

9.2 Fail-Secure Door Lock

Fail-secure means that if the power should fail at a door (perhaps due to a power outage or equipment failure), the door will automatically lock and not allow entrance, but will continue to allow egress. Power is required to unlock the door. A fail-secure door ensures a secured area remains secure regardless of the situation. A typical fail-secure application may use a door strike. In this application, the controller energizes the lock relay, causing the lock relay to change its state. In its new state the normally-open circuit is closed activating the release mechanism for the door strike on the door to be opened.