

Telebyte 209 Short Haul Modem

This document provides installation instructions for the Telebyte 209 Short Haul Modem (Keri Systems P/N SHM-232). This short haul modem can be used to assist in long-distance, direct, connections between a host computer and an access control network. The Telebyte 209 is fully compatible with PC/AT serial communication ports and requires no external power for its operation.

1.0 Specifications

1.1 Dimensions

0.85 inches High x 1.30 inches Wide x 3.00 inches Long
(2.16 cm H x 3.30 cm W x 7.62 cm L)

1.2 Connector

DB-9F with screw connection terminals

1.3 Cable Run Distance Per Wire Gauge

Using Belden 9502 or its equivalent, see Table 1

Data Rate (KBPS)	Wire Gauge		
	19	24	26
9600 Baud	4.9 Miles	3.1 Miles	1.8 Miles

2.0 Installation

The short haul modems are shipped in pairs. One modem is attached to the master controller on the access control network. The other is attached to the host computer's COM port.

NOTE: Each short haul modem has a small switch allowing the modem to be set for use with either Data Terminal Equipment (DTE) or Data Communication Equipment (DCE) devices. Please ensure that each modem's switch is set correctly.

The switch is used to set the modem to match the type of device it is connected to.

Insert a thin-blade screwdriver into the switch slot and verify the switch is turned completely counter-clockwise for a DTE application or completely clockwise for a DCE application. Applying too much pressure while turning the switch may damage the modem.

NOTE: When a KDP-252 cable is used, make sure the short haul modem switch is set for a DCE application.



Telebyte 209 Short Haul Modem

2.1 Connecting to a PXL-250 Controller

The DB-9 connector on the short haul modem and on the PXL-250 controller are both female. To make the short haul modem to controller connection a DB-9 male-to-male connector is provided (see Figure 1). Set the switch on the short haul modem to the DCE position by gently turning the switch completely counter-clockwise.

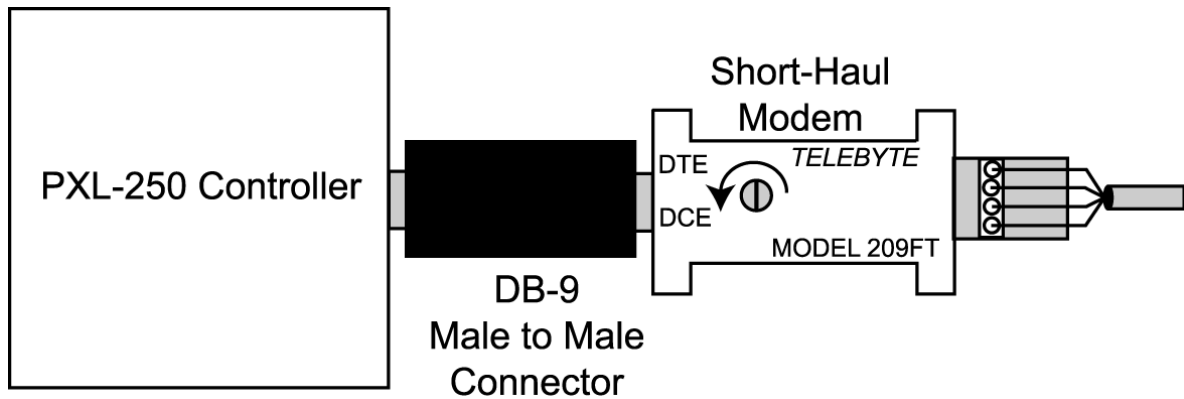

Figure 1: PXL-250 Controller to Short Haul Modem Connection

2.2 Connecting to an EntraGuard Gold Controller

A short haul modem may be used with an EntraGuard Gold master controller however, due to the size of the short haul modem, an extension cable must be made to allow the modem to be located outside of the controller box so the box may close properly.

The DB-9 connector on the short haul modem and on the EntraGuard Gold controller are both female. To make the short haul modem to controller connection two DB-9 male connectors are required and a minimum of 3 conductor cable (length as needed). Set the switch on the short haul modem to the DCE position by gently turning the switch completely counter-clockwise.

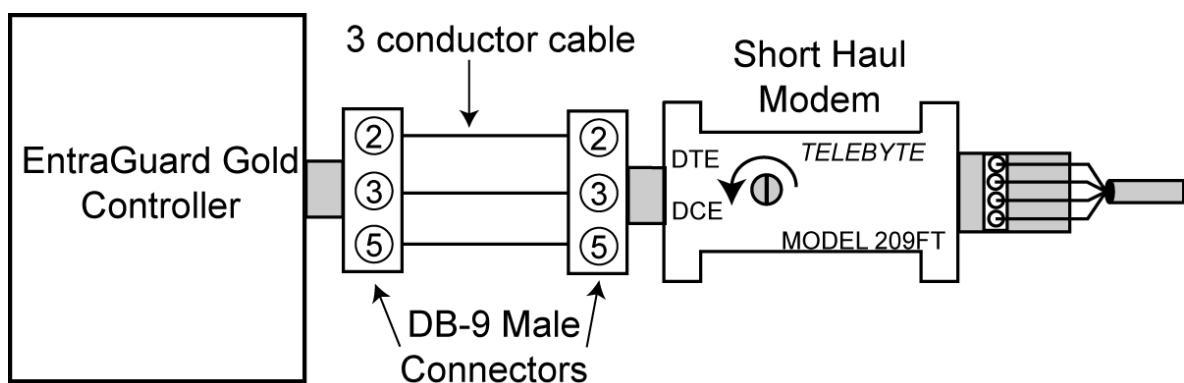

Figure 2: EntraGuard Gold Controller to Short Haul Modem Connection

Telebyte 209 Short Haul Modem

2.3 Connecting to the Host Computer - DB-9 to DB-9

If the host computer's COM port uses a male DB-9 connector the short haul modem can be plugged directly to the COM port (see Figure 2). Set the switch on the short haul modem to the DCE position by gently turning the switch completely counter-clockwise.

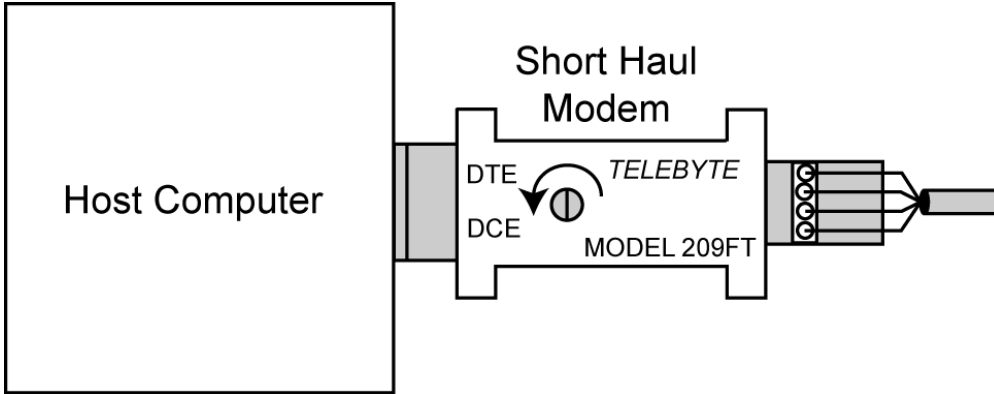

Figure 3: Host Computer to Short Haul Modem Connection

2.4 Connecting to the Host Computer - DB-9 to DB-25

If the host computer's COM port uses a DB-25 connector a DB-25 to DB-9 reduction plug must be used.

2.4.1 Using a "Straight-Through" Reduction Plug

If the reduction plug uses straight-through wiring (pins 2 and 3 on the 25 pin side go straight through to pins 2 and 3 on the 9 pin side) make the connection as shown in Figure 3. Set the switch on the modem to the DTE position by gently turning the switch completely clockwise.

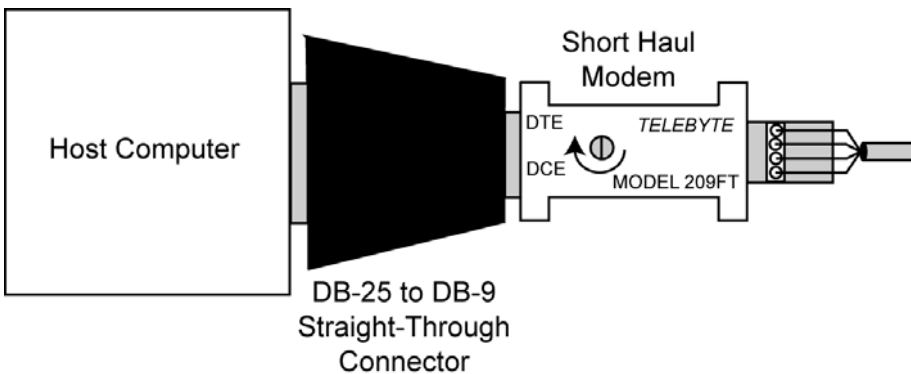

Figure 4: Host Computer to Short Haul Modem Connection Straight-Through Reduction Plug

Telebyte 209 Short Haul Modem

2.4.2 Using a "Twist" Reduction Plug

If the reduction plug uses 2-3 twist wiring (pin 2 on the 25 pin side goes to pin 3 on the 9 pin side and pin 3 on the 25 pin side goes to pin 2 on the 9 pin side) make the connection as shown in Figure 4. Set the switch on the short haul modem to the DCE position by gently turning the switch completely counter-clockwise.

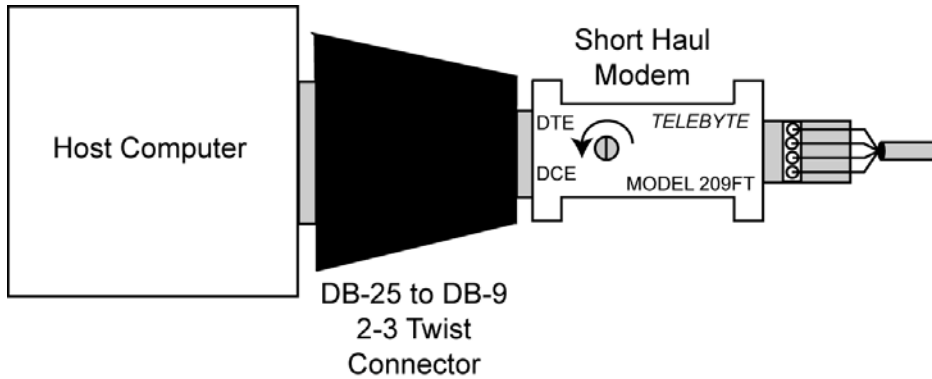

Figure 5: Host Computer to Short Haul Modem Connection 2-3 Twisted Reduction Plug

2.5 Short Haul Modem to Short Haul Modem Wiring

Two sets of twisted pair cables are used to connect the short haul modems. Connect the cable between the two modems as shown in Figure 5. The shield wire is not connected at either end of the cable.

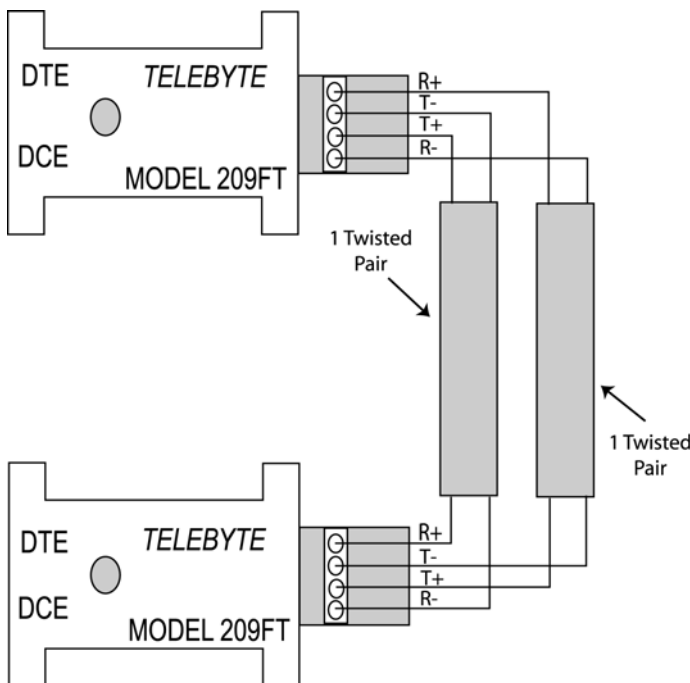

Figure 6: Short Haul Modem to Short Haul Modem Wiring Diagram

End of document.