

# Alarm Relay Board

## Installation Guide

The Alarm Relay Board (ARB) is used to provide external annunciation of controller enclosure and peripheral enclosure tamper events; either an opened enclosure cover or for an enclosure that has been removed from its mounting location (requiring additional installation steps by the Installer). The ARB enables NXT-family and PXL-family controllers to meet UL-294/CSA Class 4812 requirements for annunciation of controller tamper incidents. It is designed to accept standard types of tamper switches. The Installer must supply the external annunciation device (alarm, signal light, etc.).

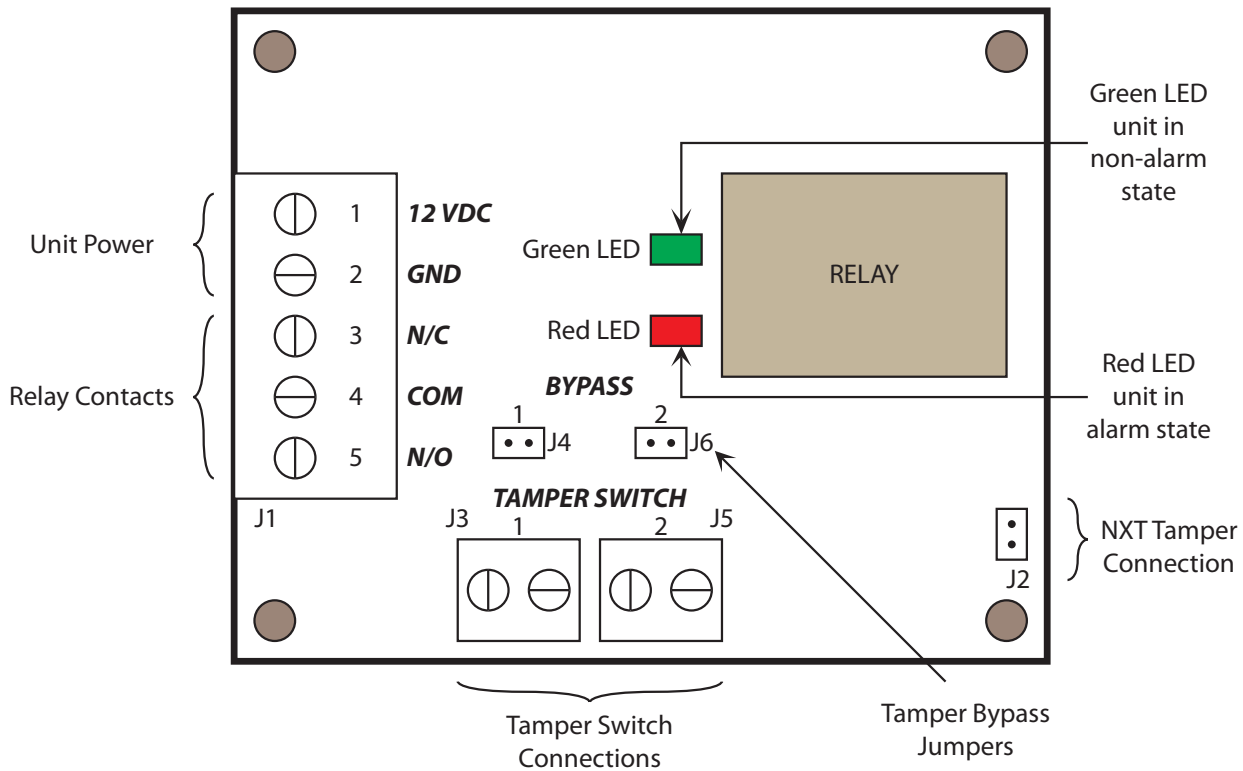

**Figure 1: Alarm Relay Board Diagram**

## 1.0 ARB PCB Installation

The NXT/PXL standard enclosure has a set of four PEMs in the upper-right corner of the enclosure to which the ARB is mounted.

The NXT-4x4 and KPS power supply enclosure has four holes in the upper-right corner of the enclosure. The ARB is mounted in this location using four stand-offs.

## 2.0 Tamper Switch Installation

Keri provides one enclosure tamper switch with each ARB. The switch is typically installed along the edge of the enclosure opposite the enclosure hinge and clear of the enclosure lock (see Figure 2 on page 2).

# Alarm Relay Board

## Installation Guide

---

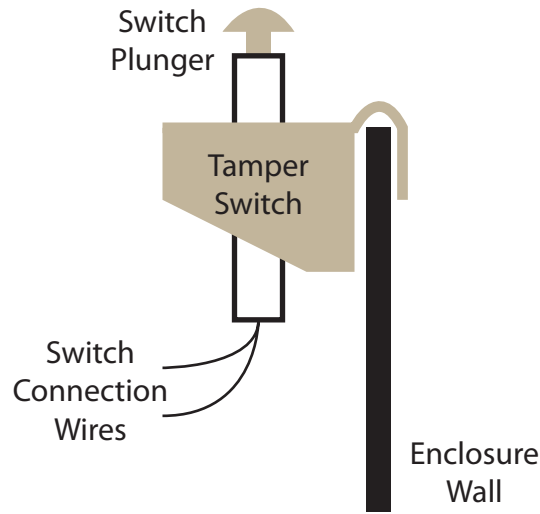

**Figure 2: Tamper Switch Installation**

### 3.0 ARB Wiring Instructions

Refer to Figure 1 on page 1 for all instructions in this Section.

#### Tamper Switches

- provides the input signal for enclosure tamper events – enclosure cover forced open and/or enclosure removed from its mounting location
- uses normally-open switches
- connection is made to either or both J3 and J5 (the switch connections are designed in parallel)
- requires two-conductor, AWG 22 wire

#### Bypass Jumpers

- used if a tamper switch is NOT used in one of the two switch positions (single-switch application)
- factory default is jumpers ON (bypasses both Tamper Switches)
- remove the corresponding jumper when a tamper switch is installed
  - remove Bypass Jumper 1 (J4) for switch position 1 (J3)
  - remove Bypass Jumper 2 (J6) for switch position 2 (J5)

#### Relay Contacts

- completes the circuit for alarm annunciation
- relay changes state as a tamper switch changes state
- Keri does NOT provide the alarm annunciation device
- requires two- or three-conductor, AWG 22 wire depending upon your alarm annunciation device

#### Unit Power

- requires 12 VDC, can be tapped off of the controller's power
- requires two-conductor, AWG 22 wire

# Alarm Relay Board

## Installation Guide

---

### NXT Tamper Connection

- allows the NXT controller to record an Enclosure Tamper event
- requires two-conductor, AWG 22 wire

## 4.0 Unit Operation

The ARB is operational as long as power is supplied to the unit. Two LEDs on the ARB provide unit status.

- Red LED – indicates alarm condition
- Green LED – indicates non-alarm condition

Verify tamper switch operation by toggling the tamper switch(es) and observing the red and green LEDs follow tamper switch state.

### Contact Keri Systems:

Keri USA	Keri UK, Ireland, Europe
2305 Bering Drive San Jose, CA 95131	Unit 17 Park Farm Industrial Estate Ermine Street Buntingford Herts SG9 9AZ UK
Telephone: (800) 260-5265 (408) 435-8400	Telephone: +44 (0) 1763 273 243
Fax: (408) 435-7163	Fax: + 44 (0) 1763 274 106
Web: <a href="http://www.kerisys.com">www.kerisys.com</a>	Web: <a href="http://www.kerisystems.co.uk">www.kerisystems.co.uk</a>
E-mail: <a href="mailto:sales@kerisys.com">sales@kerisys.com</a> <a href="mailto:techsupport@kerisys.com">techsupport@kerisys.com</a>	E-mail: <a href="mailto:sales@kerisystems.co.uk">sales@kerisystems.co.uk</a> <a href="mailto:tech-support@kerisystems.co.uk">tech-support@kerisystems.co.uk</a>

End of document.