

LAN-100 Ethernet Communication

1.0 Purpose Of This Document

This document discusses how to setup, configure and use the LAN-100 to provide LAN/WAN Ethernet connectivity between *Doors*TM and one or more PXL networks.

The following topics are covered:

- Overview
- System Requirements
- LAN-100 Setup
- *Doors*/Workstation Setup
- Using the LAN-100 with Multiple PXL Networks
- Basic Ethernet Troubleshooting

NOTE: The LAN-100 is Keri Systems' part number for the Lantronix MSS-100 Micro Serial Server. Within the Lantronix documentation, all references are made to the MSS-100.

2.0 Overview

At Keri Systems, we are always looking for ways to improve our product and provide solutions to the various implementation requests we receive. One of the most asked for requests is "Can you provide network capabilities to *Doors* and a PXL Network?" Although *Doors* was developed as a stand-alone application, there are several ways to use *Doors* in a network environment (see the [*Doors* in a Network Environment](#) Application Note for more information – P/N 01867-001).

The main limitation when using *Doors* in a network has been that the communication to the PXL network could only come from the computer physically connected to the RS-232 serial port on the master controller of the PXL network (see the [*Doors* in a Network Environment](#) Application Note for more information - P/N 01867-001). This prevents other workstations from using *Doors* to update or control the PXL network unless some sort of third party, remote control software application is used.

Keri Systems now has a solution to this problem. The LAN-100 Micro Serial Server allows the PXL network to be attached to a Local Area Network (LAN) instead of directly to a computer. This gives any workstation on a LAN (with the proper authority) the ability to communicate with the PXL network. To do this, two things must happen.

1. On the server workstation, the *Doors* folder must be shared.
2. At each client workstation that needs to be able to run the *Doors* program, create a shortcut to the *Doors.EXE* program in the shared folder on the server/workstation. Every client workstation with a shortcut to *Doors.EXE* is now able to double-click on the shortcut and start the *Doors* program.



LAN-100 Ethernet Communication

NOTE: Do NOT install the Doors software on each client workstation. By creating a shortcut on each client workstation to the shared kerisys folder on the server/workstation, each client workstation is able to use the Doors installation on the server/workstation.

When a client station communicates with the access control network, *Doors* converts data sent to a serial port into an Ethernet packet, opens an IP socket, and then sends the packet to the designated LAN-100. The LAN-100 receives the packet and sends the data to the PXL network through its serial port (see Figure 1).

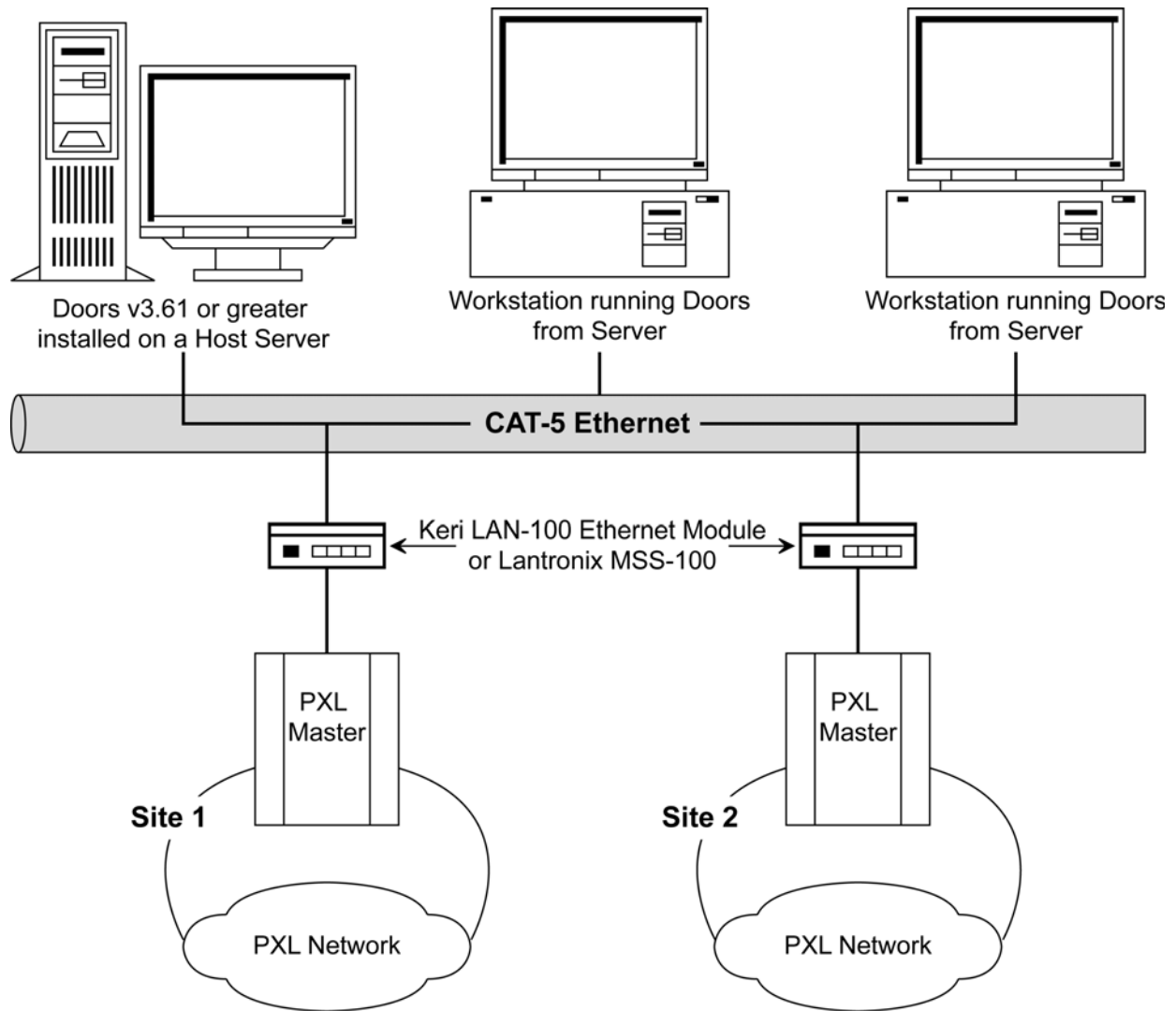

Figure 1 - Using *Doors* on a LAN Using the LAN-100

The IP socket identifies which client workstation is communicating with the LAN-100 so that when the access control network communicates with the client workstation, the data is routed back correctly.

LAN-100 Ethernet Communication

When using the LAN-100, the transfer of data through the LAN is transparent to both the *Doors* program and the PXL network. This method of communication between host computer and access control network is very robust; however there are some special considerations.

- *Doors*, version 3.61 and later, supports direct communication to the LAN-100. Refer to the *Doors Users Guide* (P/N 01914-100) for configuration information. *Doors* revision 3.51 requires the use of Redirector software provided by Lantronix. Contact Keri Systems Technical Support for information regarding LAN-100 configuration via the Redirector software.
- Whenever a *Doors* database is opened (i.e. setup users, time zone, access group, controller, door), a copy of that database is saved on the user's client workstation. All changes made by the user are made to that local copy. The original database used by the *Doors* program on the fileserver or shared folder does not receive these changes until the user clicks on the **SAVE** button, physically overwriting the original database in the fileserver or shared folder with the newly edited information from the user's client workstation. This is done to protect the original database from being affected if a user decides to cancel any changes being made.
- Although multiple users can simultaneously work in the *Doors* program, only one workstation can communicate with the PXL access control network at a time. There is no way to simultaneously control an access control network from more than one workstation. This means that only one user at a time may be downloading information to the network, receiving information from a network, monitoring a network, or manually operating a network. When that user has completed work, that user must use the Net Disconnect command (the Operate > Net Disconnect pull-down menu option) to manually disconnect from the access control network and that user must close the *Doors* program to allow another user to gain access to the access control network.
- There is no encryption available to hide the data going across the LAN. Ethernet, by its nature, is not secure.



LAN-100 Ethernet Communication

3.0 System Requirements

Both the server and the client workstations, and the LAN must meet the following system requirements for proper operation of *Doors* and the LAN-100.

- PC compatible computer using a Pentium™-90 or faster microprocessor
- minimum of 16 MB of system RAM
- SVGA color monitor with SVGA graphics card (800 x 600 minimum resolution for use with small fonts and 1024 x 768 minimum resolution for use with large fonts)
- CD-ROM, keyboard, and mouse or other pointing device
- 3.5 inch floppy disk drive or CD-ROM burner (optional for system backup)
- 100 MB of available hard disk space
- 10BaseT (or greater) network card
- twisted-pair network cabling (NOT coax)
- TCP/IP network protocol running in a *Windows* network
- one of the following operating systems
 - *Windows 95*™
 - *Windows 98*™
 - *Windows 2000*™
 - *Windows ME*™
 - *Windows XP*™ (for *Doors* v3.74 or greater)
 - *Windows NT*™ v4.0 (or greater)¹

1. Keri Systems recommends the use of Windows NT when using the LAN-100 for LAN/WAN Ethernet communication.

LAN-100 Ethernet Communication

4.0 LAN-100 Setup

NOTE: To set up the LAN-100 you must have a technical knowledge of networks and networking in a PC environment. Please consult your system or network administrator to resolve any networking issues that might occur.

LAN-100 setup is done in four steps.

1. Connect the LAN-100 to the LAN.
2. Install EZWebCon software (the LAN-100 configuration software from Lantronix).
3. Assign an IP address to the LAN-100.
4. Configure the LAN-100.

Once all LAN-100s are setup, the *Doors* program must be configured to communicate with these units. Please refer to the *Doors Users Guide* (P/N 01914-100) for configuration information.

NOTE: Steps 3 and 4 must be run for each LAN-100 in the access control network. Each LAN-100 must have a unique IP address.

NOTE: For detailed information on how to configure the LAN-100 refer to the Lantronix MSS-100 Installation Guide on the Lantronix CD-ROM shipped with the LAN-100 unit.

4.1 Connect the LAN-100 to the LAN.

Refer to Figure 2 on page 6 for a connection diagram.

1. Connect the LAN-100's 10/100 Ethernet port to the LAN port designated for use by the LAN-100 using the RJ-45 cable provided with the LAN-100 .
2. Connect the LAN-100's Serial port to the master controller of the PXL access control network using a Keri Systems KDP-251 cable; or make a cable using the pin-out information provided in Table 1 on page 6.
3. Connect the power supply's 5 VDC power jack to the power connection on the LAN-100. Plug the power supply into a 110 VAC socket.



LAN-100 Ethernet Communication

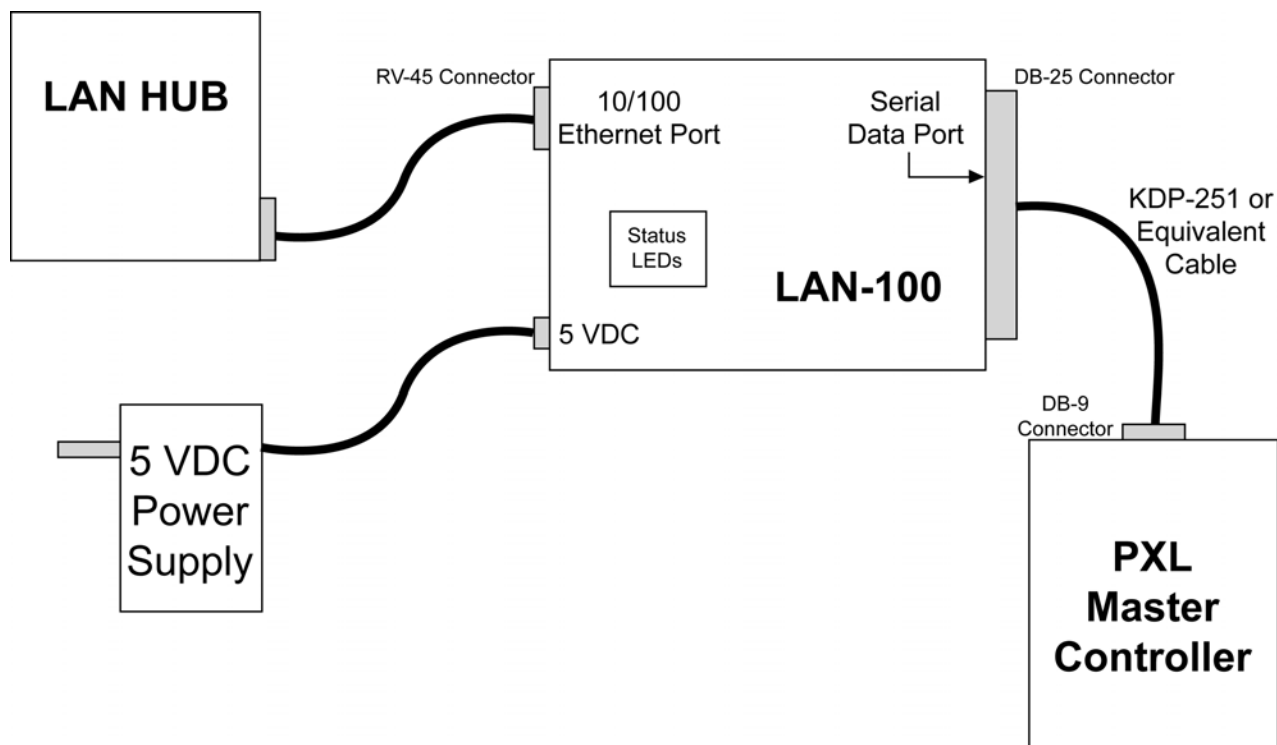

Figure 2 - LAN-100 Connection Diagram

Table 1: KDP-251 Serial Data Cable Wiring

| DB-25F (at the LAN-100) | RS-232 Data Cable Standard Wire Color | DB-9M (at the PXL) |
|------------------------------------|--|-------------------------------|
| Pin 2 – TxD | Green | Pin 2 – RxD |
| Pin 3 – RxD | Red | Pin 3 – TxD |
| Pin 7 – Ground | Black | Pin 5 – Ground |
| Connector Body | Silver (Shield) | no connection |

LAN-100 Ethernet Communication

4.2 Install EZWebCon Software

The LAN-100 is configured through EZWebCon, a program provided with the LAN-100.

NOTE: These instructions refer to version 2.0/1 of the EZWebCon utility program. If you are using an earlier version of this program, the screens will appear somewhat different, but the process for LAN-100 configuration remains the same.

1. Place the Lantronix CD-ROM into the server workstation's CD-ROM tray. Using the autorun feature of the operating system the CD will automatically open its Tools and Support window (see Figure 3). If it does not, browse the CD and locate the **ezwebcon.exe** program. Double-click on the **ezwebcon.exe** program name and the EZWebCon program window opens.

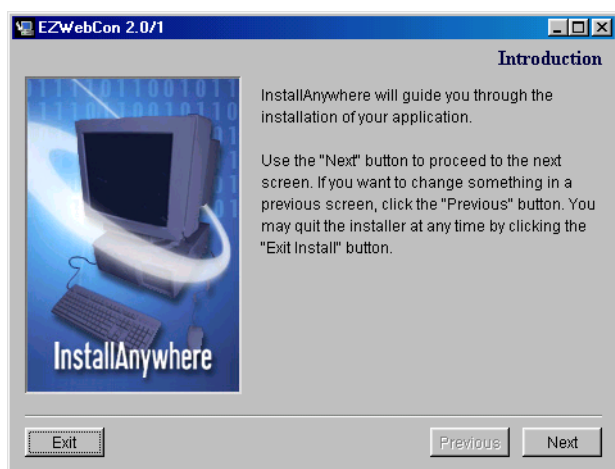



Figure 3 - EZWebCon Software Installation

2. Click on the button and follow the instructions. If necessary, refer to the installation instructions provided in the LAN-100 Users Manual to install the software.

LAN-100 Ethernet Communication

4.3 Assign an IP Address

An IP address must be assigned to the LAN-100 to uniquely identify it on the LAN. Obtain a valid IP address from the LAN Administrator. If the LAN Administrator determines that a subnet address is also necessary, obtain the subnet address from the LAN Administrator as well.

1. Locate and run the EZWebCon program. Either use the Programs > EZWebCon > EZWebCon option from the operating system  button or use Windows Explorer to navigate and double-click on the Program Files > Lantronix > EZWebCon > EZWebCon.exe program listing. The EZWebCon window appears.

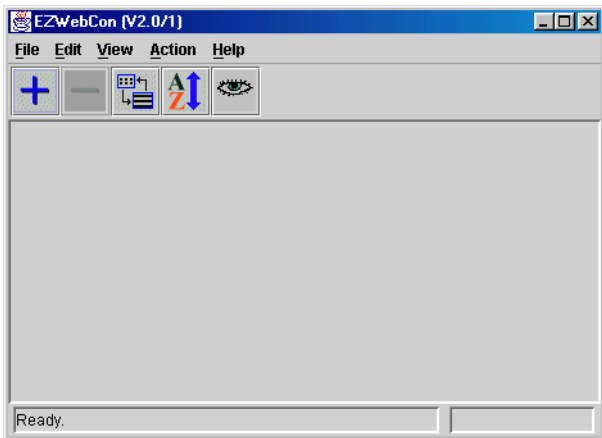

Figure 4 - EZWebCon Window

2. Click on the Action pull-down menu option and a list of possible actions appears.

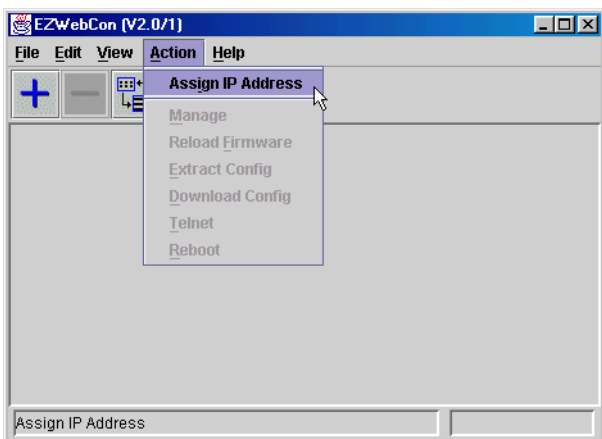

Figure 5 - Enter IP Address Assignment Window

LAN-100 Ethernet Communication

3. Click on the **Assign IP Address** menu option. The Assign IP Address to Server window appears.

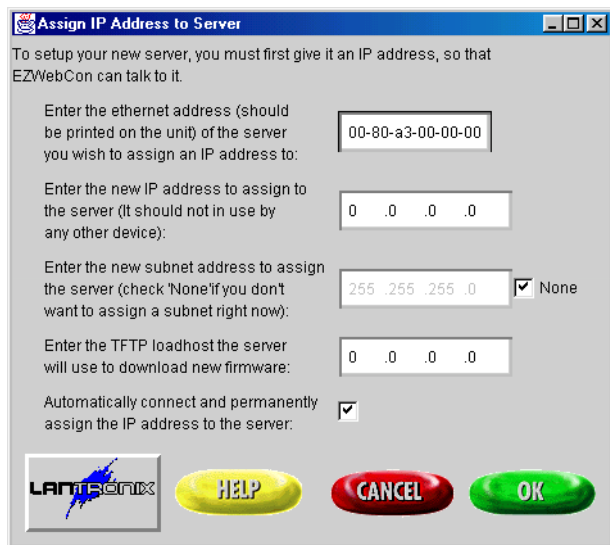



Figure 6 - Assign IP Address to Server Window

4. In the "Enter the Ethernet address" field, enter the Ethernet address. The address is found on the label on the back of the LAN-100 module.
5. In the "Enter the new IP address" field, enter the IP address (obtained from the LAN Administrator) to be assigned to the LAN-100.
6. If the LAN Administrator has determined that a subnet address is necessary, locate the "Enter the new subnet address" field and deselect the None check box (the box should be empty). Now enter the subnet address (obtained from the LAN Administrator) in the "Enter the new subnet address" field.
7. The "Enter the TFTP loadhost" field only applies when downloading new firmware to the LAN-100. It is not used for standard LAN-100 configuration and should be left with its default values.
8. The check box in the "Automatically connect and and permanently assign field" should have a check mark in the box; if not, click in the box and a check mark appears.
9. Click on the  button and the configuration process begins.
10. At some point during the configuration process, the program will ask you to turn on or cycle the power on the LAN-100 server.

LAN-100 Ethernet Communication



Figure 7 - Cycle Server Power

11. Cycle or turn on power to the LAN-100 server. The configuration process recognizes when the server has been reset, sends configuration information, and then informs you when IP address assignment is complete. In this example, IP address 123.456.7.89 has been assigned.

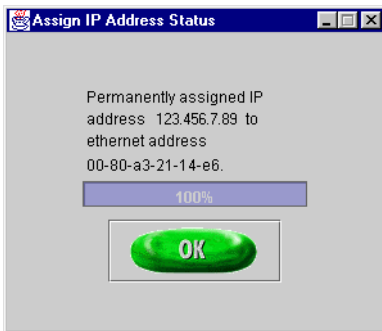



Figure 8 - Completed IP Address Assignment

12. Click on the  button. The LAN-100 IP address has been assigned and the EZWebCon program window reappears.

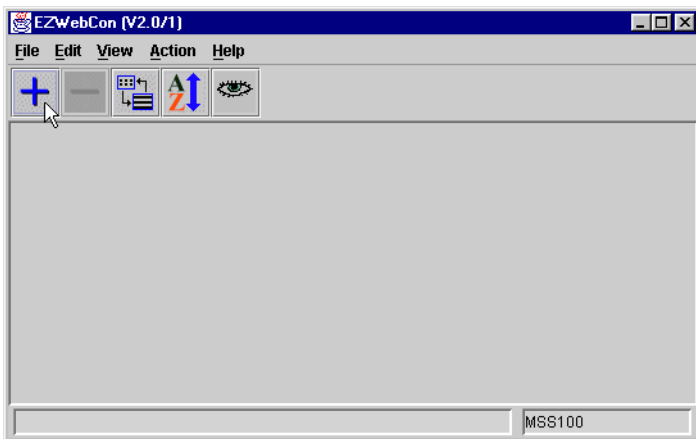

Figure 9 - EZWebCon Program Window

LAN-100 Ethernet Communication

13. Click on the  button and the Add a DNS Name or IP Address window appears. Enter the IP Address of the LAN-100.



Figure 10 - Add LAN-100 IP Address

14. Click on the  button and the EZWebCon program window reappears, displaying the LAN-100 with its IP Address.

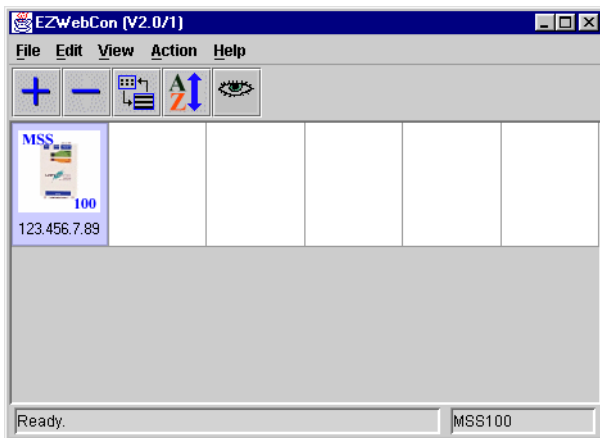



Figure 11 - LAN-100 Ready for Configuration Management

15. Repeat this Section beginning with Step 2 for each LAN-100 that will be connected to the access control network. As each LAN-100 is assigned an address, it will appear in the EZWebCon program window as shown in Figure 11.

LAN-100 Ethernet Communication

4.4 Configure the LAN-100

Now the LAN-100 must be configured with its data transfer parameters.

1. Locate and run the EZWebCon program. Either use the Programs > EZWebCon > EZWebCon option from the operating system  button or use Windows Explorer to navigate and double-click on the Program Files > Lantronix > EZWebCon > EZWebCon.exe program listing. The EZWebCon window appears with any available LAN-100 units displayed (see Figure 11 on page 11).
2. Click on the Action pull-down menu option and a list of possible actions appears.

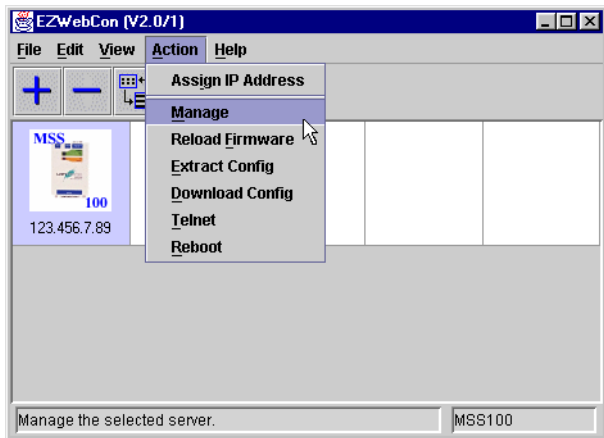

Figure 12 - Enter LAN-100 Configuration Management Menu

3. Click on the **Manage** menu option. The MSS Management window appears.

LAN-100 Ethernet Communication

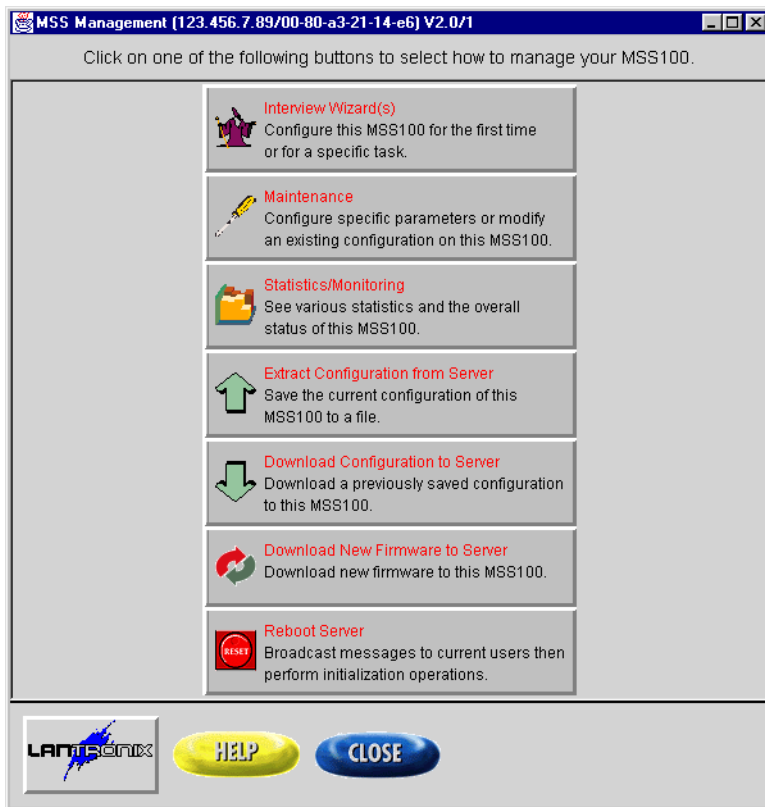

Figure 13 - LAN-100 Configuration Management

4. Locate and click on the  button. The Interview Selection window appears.

LAN-100 Ethernet Communication

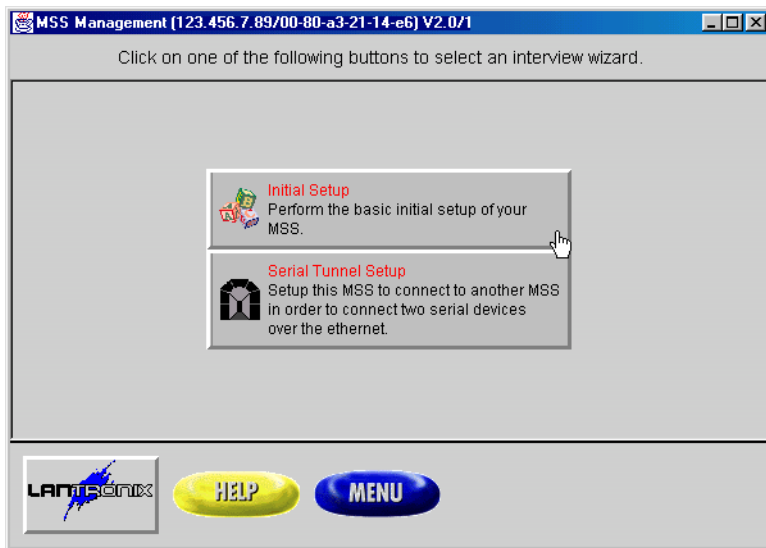

Figure 14 - Interview Selection Window

5. Locate and click on the  button. The Basic LAN-100 Setup Introduction window appears.

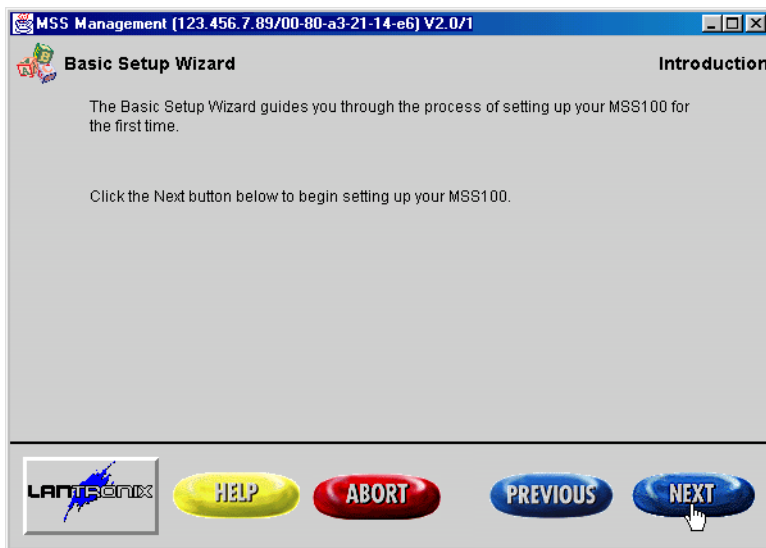

Figure 15 - Basic LAN-100 Setup Introduction Window

LAN-100 Ethernet Communication

6. Click on the  button. The LAN-100 TCP/IP Setup window appears.

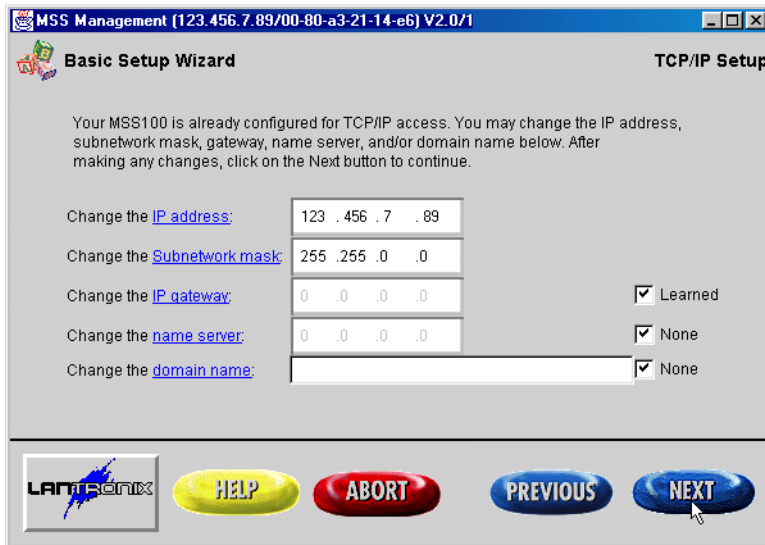



Figure 16 - LAN-100 TCP/IP Setup Window

7. In the "Change the IP address:" field, enter the IP address for the LAN-100.
8. In the "Change the Subnetwork mask:" field, leave the subnetwork mask value. This value will reflect what (if anything) was entered as the subnet address (see page 9).
9. In the "Change the IP gateway:" field, verify the **Learned** check box is selected (there is a check in the box).
10. In the "Change the name server:" field, verify the **None** check box is selected (there is a check in the box).
11. In the "Change the domain name:" field, verify the **None** check box is selected (there is a check in the box).
12. Click on the  button. The NetWare Setup window appears.



LAN-100 Ethernet Communication

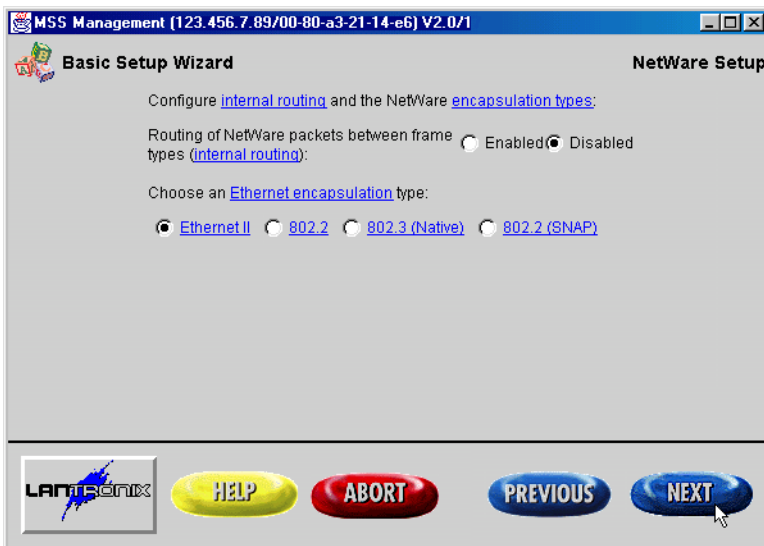



Figure 17 - NetWare Setup Window

13. In the "Routing of NetWare packets between frame types:" field:
 - - If the LAN-100 is to be used in a NetWare environment, verify the **Enabled** radio button is selected.
 - - If the LAN-100 is not in a NetWare environment, verify the **Disabled** radio button is selected.
14. In the "Choose and Ethernet encapsulation type:" field, verify the **Ethernet II** radio button is selected.
15. Click on the  button. The Serial Port Setup window appears.

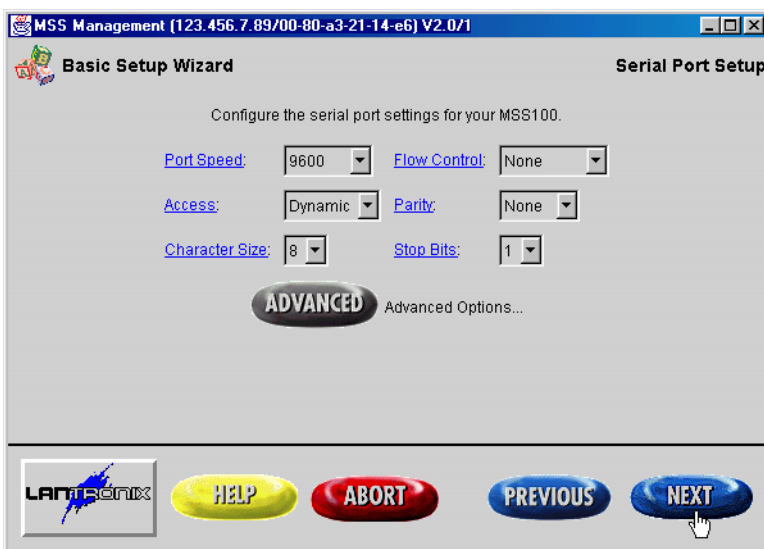

Figure 18 - Serial Port Setup

LAN-100 Ethernet Communication

16. There are six fields that need to be set (see Figure 18 on page 16). Each of the six fields has a pull down menu; click on the down arrow beside each field and a list of available options for that field appears (the Advanced Options should be left at their default values). Click on each pull-down menu, scroll through the list of options and select the option per the following list.

Table 2: Serial Port Setup Options

| | |
|----------------|-----------|
| Port Speed | 9600 baud |
| Access | Dynamic |
| Character Size | 8 |
| Flow Control | None |
| Parity | None |
| Stop Bits | 1 |

17. When complete, click on the  button and the Configuration Interview Complete window appears.

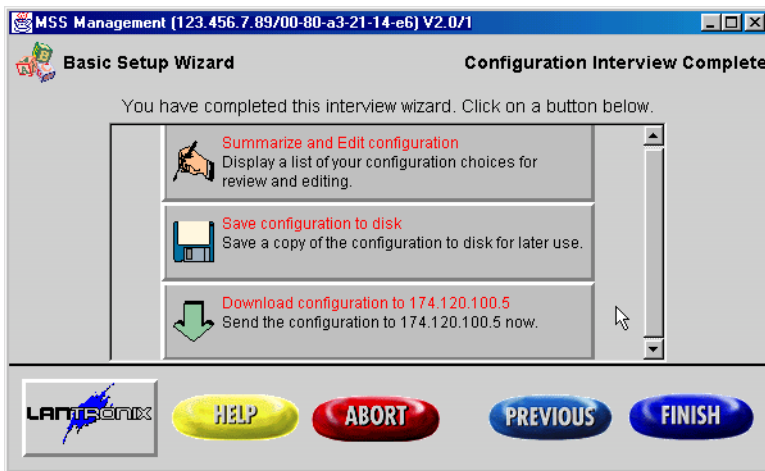

Figure 19 - Configuration Interview Complete Window

18. Click on the "Download configuration to (IP Address)" button. A Reboot Request window appears.

LAN-100 Ethernet Communication

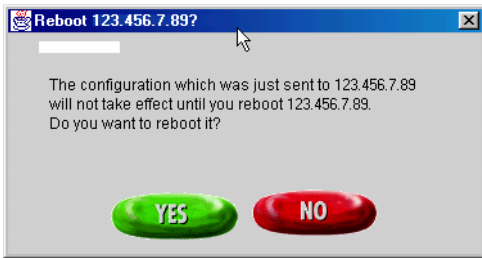



Figure 20 - Reboot Request Window

19. The LAN-100 must be rebooted for all the configuration changes to take effect. Cycle power on the LAN-100 unit and click the  button. When the LAN-100 comes online with all the new configuration information, the following window is displayed.

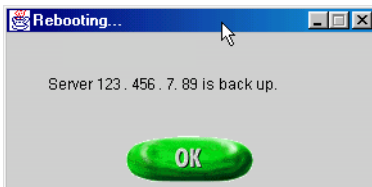

Figure 21 - LAN-100 Back Online

20. Click the  button. The LAT Setup window appears (see Figure 22).

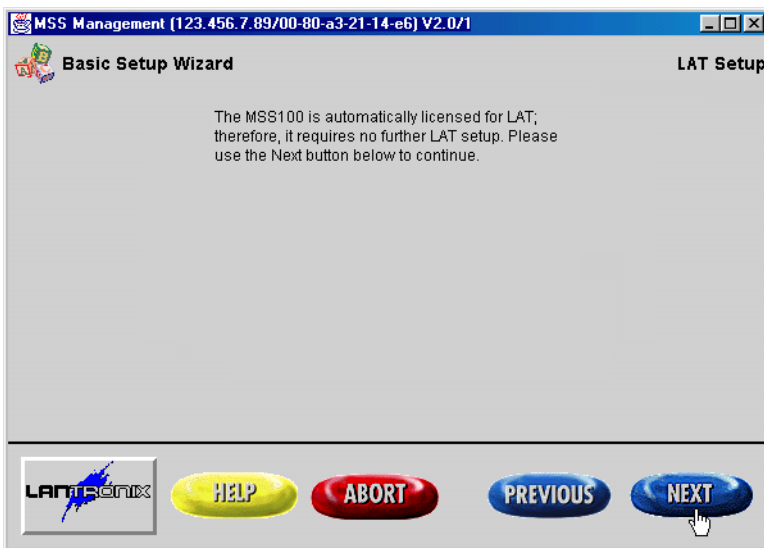

Figure 22 - LAT Setup Window

LAN-100 Ethernet Communication

21. The Setup program recognizes that Local Area Terminal (LAT) setup has already been performed as a part of the LAN-100 configuration process, so no additional setup is necessary.

Click the  button.

22. The LAN-100 is now ready for use.

23. Repeat Section 4.4, beginning with Step 2 on page 12 for every LAN-100 that is attached to the access control network.



LAN-100 Ethernet Communication

5.0 Using The *Doors* Databases

Whenever a *Doors* database is opened (i.e. setup users, time zone, access group, controller, door), a copy of that database is saved on the user's workstation. All changes made by the user are made to that local copy. The original database used by the *Doors* program on the fileserver or shared folder does not receive these changes until the user clicks on the **SAVE** button, physically overwriting the original database in the fileserver or shared folder with the newly edited information from the user's workstation. This is done to protect the original database from being affected if a user decides to cancel any changes being made.

What this means is that there can be database change conflicts if multiple users edit the same database simultaneously. There are two situations in which this can occur.

1. There are no notifications to indicate a database has been changed since the last time a user opened that database. If User-A and User-B both have the same database open and User-B saves changes to that database, User-A must close the database and then reopen it to see the changes made by User-B.
2. Suppose User-A and User-B have the same database open and both are making changes to that database. If User-A saves one set of changes and then User-B saves a different set of changes, the changes made by User-B (the last set of changes saved) will overwrite the changes made by User-A.

For these reasons, Keri Systems strongly recommends that only one user/workstation be allowed to view or modify a database at a time. Although multiple users can simultaneously work in the *Doors* program, only one workstation can communicate with the PXL access control network at a time. There is no way to simultaneously control an access control network from more than one workstation. This means that only one user at a time may be downloading information to the network, receiving information from a network, monitoring a network, or manually operating a network. When that user has completed work, that user must use the Net Disconnect command (the Operate > Net Disconnect pull-down menu option) to manually disconnect from the access control network and that user must close the *Doors* program to allow another user to gain access to the access control network.

LAN-100 Ethernet Communication

6.0 Using The Lan-100 With Multiple PXL Networks

Doors can be used in "Sites" mode. Sites mode allows the user to manage multiple PXL networks from one installation of *Doors*. The connection to a site is usually made via modem and each site has its own phone number. However, Sites mode can be done using LAN-100s in place of the modems. In this case, each site has its own IP address.

NOTE: If you decide to use LAN-100s to communicate with multiple sites, all sites must be converted to LAN-100 communication and all communication must be made through the LAN. You cannot have some sites communicate via LAN and other sites communicate via modem, and you cannot configure the system to be switchable between the two communication methods.

The complete process for configuring *Doors* for operation in TCP/IP Sites mode is described in the *Doors Users Guide, Section 8 – Multiple Sites* (P/N 01914-100). Please refer to this document for multiple site TCP/IP configuration information.



LAN-100 Ethernet Communication

7.0 Ethernet Troubleshooting Guide

This section provides some basic troubleshooting information should you have trouble connecting to a LAN-100.

NOTE: This section assumes you have a working knowledge of computer networks. For the troubleshooting process, you should consult with the system or network administrator.

7.1 Verify the TCP/IP Settings in the *Doors* Program

1. Check the IP address and port number (see Figure 23).
 - The IP address in the *Doors* program should match the IP address programmed into the LAN-100 unit.
 - By default, the Server's Ethernet Port Number is set to 10021 and should not be changed unless it conflicts with another device on the host computer. Please consult your system or network administrator.
 - By default, the Remote Site Port Number is set to 3001 and should not be changed unless instructed to do so by the system or network administrator.

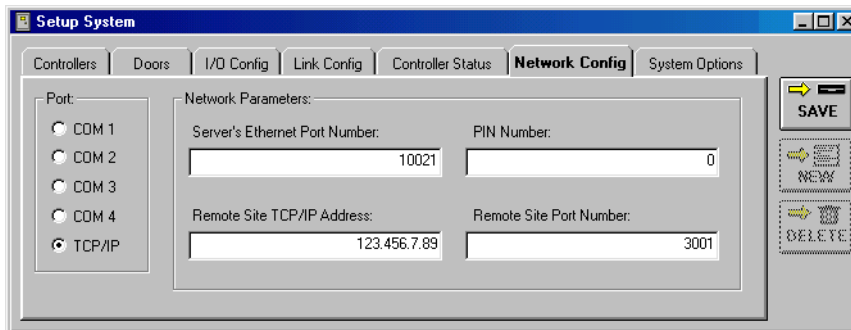



Figure 23 - *Doors* TCP/IP Settings

2. Once all the information has been verified as being correct, click on the  button.
3. You may need to close and then re-open the *Doors* program for any changes to take place.

LAN-100 Ethernet Communication

7.2 Verify the LAN-100 Settings

1. There are three ways to verify the LAN-100 settings. Refer to the Lantronix Reference Manual for detailed instructions on using each method.

NOTE: It is important to remember when searching for information in the Lantronix documentation that the LAN-100 is referred to as the MSS-100.

- EZWebCon utility - maintenance
- Telnet - show port, show server commands
- HTTP web browser utility - server properties, port properties
(http://www.lantronix.com/htmfiles/prodinfo/prodman/manuals/mss_ref/html/r_title.htm)

Review the displayed configuration for the LAN-100. Verify the following LAN-100 settings.

- Access Mode is set to **Dynamic**
- Hardware Flow Control is set to **None**
- Autostart is **Disabled**

7.3 Verify the LAN-100 is Online

1. Ping the IP address of the LAN-100. If the ping fails, that means a communication connection cannot be made. Possible reasons are:
 - There is no power to the LAN-100 unit.
 - The IP address was not programmed properly.
 - Another device on the network has that same IP address.
 - The workstation has not been granted access to that segment of the network.

Contact the system or network administrator to resolve these issues.



LAN-100 Ethernet Communication

7.4 Verify the Serial Port on the LAN-100 is Available

Use Telnet to login on the LAN-100 as the privileged user. Refer to the MSS-100 documentation on the Lantronix CD-ROM for instructions on how to connect using Telnet. Once connected and logged in, enter the following command at the Local 1 prompt to display the port status.

Local 1 >> **Show Port**

1. Verify the Access Mode is set to **Dynamic**.
2. Verify the Connection State is **Idle**. The Connection State is shown in parenthesis beside the Physical Port 1 callout.
 - If the Connection State is **Job Service**, the LAN-100 is being used by another workstation. The Current Session field displays the IP address of the workstation to which the LAN-100 is connected.
 - If the Connection State is **Local**, the master PXL controller is communicating with the LAN-100.
 - Enter the following command at the Local 1>> prompt to logout of the port and change the Connection State to **Idle**.

Local 1 >> **logout**

3. Verify Autostart is **Disabled**.
 - The Autostart character must be either blank or set to **/A1**.
4. Verify DSRLLogout is **Enabled**.

7.5 Contact Lantronix Technical Support

1. If you continue to have problems connecting, detailed information is provided by Lantronix. Please refer to the Lantronix Support web site at the following URL.

<http://www.lantronix.com/support/>