

# Wiegand Elevator Control Panel

Keri has modified its PXL-250W Tiger Controller and SB-293 Satellite Board to tailor a system for Wiegand reader, elevator control applications. The LC-202W Elevator Control Panel is made up of an LC-200W Tiger Controller Board and an SB-200 Satellite Board, together in a standard PXL-250 enclosure. The LC-208W Elevator Control Panel combines four LC-200W panels with four SB-200 Satellite Boards in a rugged enclosure.

The LC-202W provides two floor increments of elevator control at an economical price. Users can mount a single Wiegand Reader inside an elevator cab and connect it to up to 12 LC-202Ws to control floor access for up to 16 floors. Used in conjunction with *Doors32* software, this combination can be a very cost-effective elevator control solution.

The LC-208W provides eight floors of elevator control in a small, integrated package. As with the LC-202W, a single Wiegand Reader is mounted inside an elevator cab and then is connected to the LC-208W, providing controlled access for up to eight floors in a single enclosure.

Any combination of LC-202Ws and LC-208Ws may be combined to control greater than eight floors.



*Check with local authorities when installing Elevator Control panels. Your elevator control application must meet all local and national safety codes. The Main or Lobby Floor cannot have access control applied – all people must be able to exit the elevator at all times on at least one common, ground-level access floor.*

## 1.0 Considerations

To ensure timely operation, the following considerations apply when using *Doors32* software for elevator control.

- One reader in the elevator car controls access for all floors. This reader is attached to all antenna inputs at each controller assigned to a floor. This wiring scheme results in the one reader being responsible for access requests for all floors.
- The reader's read range is reduced, possibly up to 25%, due to the reader signal being shared between multiple controller antenna inputs.
- To ensure the Wiegand reader signal reaches all controllers with good signal strength, a Wiegand Distribution Amplifier (P/N 04197-001) is required.
- The reader's LED and beeper are used to indicate card presentation only, and does not indicate if access has been granted or denied as in a standard access control reader application.



# Wiegand Elevator Control Panel

- User card presentation to the reader is critical. To ensure that all controllers have the opportunity to respond to a card read, the card must be presented to the reader for a greater period of time (perhaps up to 2 seconds depending upon the length of the cable run and the number of controllers attached to the network). This allows all antenna inputs on all controllers the time necessary to respond to the card.

## 2.0 Hardware and Software Operating Requirements

All standard hardware and software requirements for *Doors32* software apply (refer to the Doors32 Users Guide – P/N 01821-002). To support elevator control, the following additional software and firmware requirements must be met.

- The *Doors32* software must be at revision 3.42 or greater.
- The controller firmware must be at revision 6.3.42 or greater.

## 3.0 Specifications

### 3.1 Unit Dimensions

- LC-200W Controller PCB with or without SB-200 Satellite Board
  - 7.00 inches high by 6.00 inches wide by 1.75 inches deep, including wiring connectors
  - (17.78 cm by 15.25 cm by 4.45 cm)
- LC-200W Controller PCB with an LCD-1 Alpha/Numeric Display
  - 8.25 inches high by 6.00 inches wide by 1.75 inches deep, including wiring connectors
  - (20.95 cm by 15.25 cm by 4.45 cm)
- LC-202W Enclosure
  - 9.70 inches high by 8.20 inches wide by 2.60 inches deep
  - (24.64 cm by 20.83 cm by 6.60 cm)
- LC-208W Enclosure
  - 18.50 inches high by 15.25 inches wide by 4.00 inches deep
  - (47.00 cm by 38.75 cm by 10.20 cm)

### 3.2 Operating Temperature and Humidity Range

- 0°F to 140°F (-18°C to 60°C)
- 0% to 90% Relative Humidity, non-condensing

### 3.3 Power Requirements

- 12 VDC @ 750 mA for the LC-202W panel
- 12 VDC @ 3 A for the LC-208W panel

# Wiegand Elevator Control Panel

## 3.4 Current Draw

- 500 mA maximum current draw for a Controller with all options installed (SB-200, LCD-1, and Wiegand reader)
- 120 mA maximum for a LC-200W Controller
- 150 mA maximum for an SB-200 Satellite Board
- refer to the Wiegand readers' product manual for current requirements for the Wiegand Reader

## 3.5 Controller Memory Retention

- 5 year lithium battery backup to support controller RAM and real-time clock

## 3.6 Floor Control Relay Contact Rating

- 1 Amp @ 24 VDC

When connecting to elevator control systems and the floor selection buttons, please verify the elevator system voltages. Most elevator systems operate on DC or AC voltages higher than the 24 VDC @ 1 Amp rating at which Keri Systems' elevator controllers are rated.

Keri Systems recommends establishing a system connection point at which the access control system and elevator control system connect, and to which both the access control company and the elevator company have access. This assists in making the connections between the systems and in allowing for independent system troubleshooting.

- If the system voltages are different (or if you wish to fully protect the access control system from transient voltage spikes), these connections should be made via isolation relays or relay control boards.
- If the system voltages are the same and both systems are fully protected, or if the system connections are made between dry relay contacts, you may only need to use a terminal strip for these connections.

Please consult your local building codes for proper installation requirements and check with local permit departments to verify compliance. Elevator systems have **Life Safety** requirements and may also require a connection to a fire control system.



# Wiegand Elevator Control Panel

## 3.7 Cable Requirements

- RS-232 Serial Cable
  - four conductor, shielded, stranded AWG 24 wire (Belden 9534 or a heavier gauge)
  - 50 foot maximum length (per RS-232 industry specification – greater lengths are not recommended)
- RS-485 Network Cable
  - one twisted, shielded pair of conductors, stranded, AWG 24 wire (Belden 9501 or a heavier gauge)
  - 4,000 foot total network length (per RS-485 industry specification – greater lengths are not recommended)
- Input Power
  - two conductor, stranded, AWG 18 wire (Belden 8461 or a heavier gauge)
  - 200 foot maximum length

*NOTE: On long power cable runs, the cable resistance causes a drop in voltage at the end of the cable run. Be sure your power supply provides 12 VDC at the end of the cable run.*

- Readers to Panel
  - Wiegand Readers require seven conductor, shielded, stranded AWG 24 wire (Belden 9537 or a heavier gauge)
- Panels Daisy-Chained
  - Wiegand Readers require three conductor, shielded, stranded AWG 24 wire (Belden 9533 or a heavier gauge)
- Output Connections
  - two conductor, stranded AWG 22 (Belden 9532 or a heavier gauge)

*NOTE: The Floor Control Relay may require a heavier gauge of wire depending upon the current demands of the elevator panel and the length of the wiring run.*

*NOTE: If plenum cable is required, please reference the Belden equivalent to the cable listed above.*

# Wiegand Elevator Control Panel

## 4.0 Controller Installation

Sections 4.1 and 4.2 are quick lists of things to do and not to do when installing LC-202 and LC-208 panels.

### 4.1 Do

- Plan ahead to meet power and telephone requirements for your system (1 phone line for the host computer and one for each master LC-200W in each network).
- Mount controllers and the distribution amplifier (for LC-202W applications) in environmentally suitable areas – they require protection from weather and from temperature/humidity extremes.
- Mount the controller and the distribution amplifier (for LC-202W applications) at least 3 feet away from the controller's power supply to prevent EMI radiated from the power supply from affecting the controller.
- Use the enclosure as a mounting template to mark drilling holes for permanent mounting.
- Consider mounting requirements - central versus distributed.
  - Central mounting places all controllers in one location, running lengths of cables out to each door to support readers, inputs and outputs.
  - Distributed mounting places each controller near the door it supports running short lengths of cable out to each door, but running a long network communication cable.
- Note the locations of the knockouts in the enclosures and remove the appropriate knockout for the easiest cable routing into the controller.
- Route all controllers in a network in a single, continuous daisy-chain.
- Route cables in accessible areas for ease of maintenance.
- Connect all controllers to a quality earth ground.
- Add transient suppression across electric devices attached to a controller output.
- Verify the controller's supply voltage is 12 VDC – long power line runs cause a drop in voltage at the end of the run.
- Verify proper operation of the host computer's COM port.
- Attach the reader to be used for card enrollment to the master controller (this reader can be used for access control as well as enrollment, but during the enrollment process the door associated with the enrollment reader will not allow access until the enrollment process is complete).

### 4.2 Do Not

- Make modem phone line connections through PBX telephone switching systems - most modems are not compatible with PBX systems leading to disconnection problems with the modem.
- Locate the LC-200W controller near EMI sources - EMI sources can affect the performance of the controller.
- Use switching power supplies - they are EMI sources.
- Route network and reader cables beside power cables - transients on the power cables may be picked-up by network and reader cables.
- Stretch or over-tension cables.



# Wiegand Elevator Control Panel

---

- Route cables over sharp objects.
- Let the cables get tangled.
- Mix LC-200Ws with PXL-100s in the same network.
- Connect earth ground to the network cable shield - the LC-200W automatically connects earth ground to the shield at one point on the network to prevent ground loops.
- Use gender changer plugs when making RS-232 serial communication connections (unless you know it is a "straight-through" plug) - gender changers may have internal wiring changes that can disrupt communications.



# Wiegand Elevator Control Panel

## 5.0 Wiring Connections

Before performing any wiring or connection operations, ensure that controller power is **OFF**. Serious damage to sensitive components on the controller may occur if wiring changes are made while controller power is on.

- Refer to Figure 1 and Figure 2 on page 8 when reviewing the information throughout Section 5.2 beginning on page 10.
- Refer to Figure 3 on page 9 when reviewing the information throughout Section 5.3 beginning on page 16.

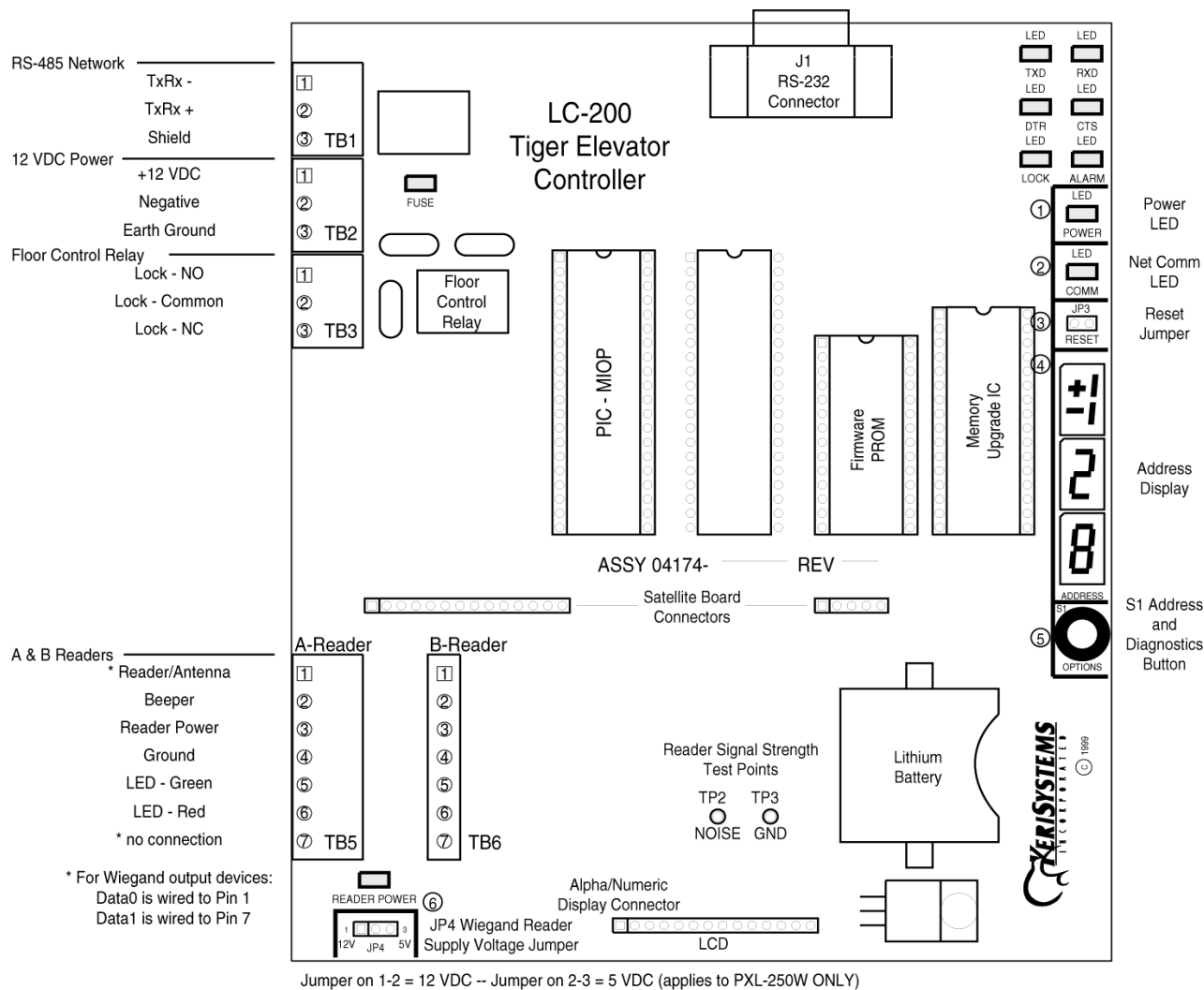

Figure 1: The LC-200W Elevator Controller

# Wiegand Elevator Control Panel

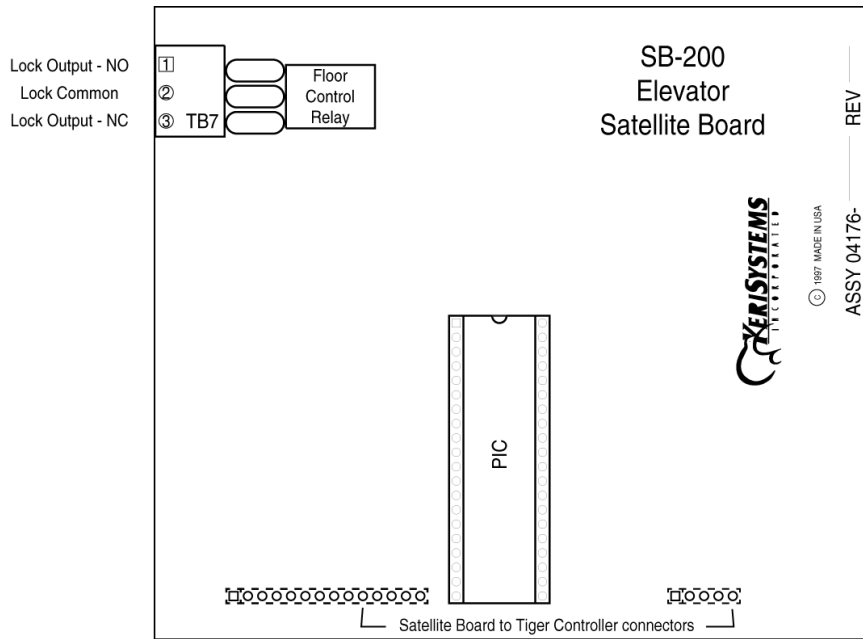
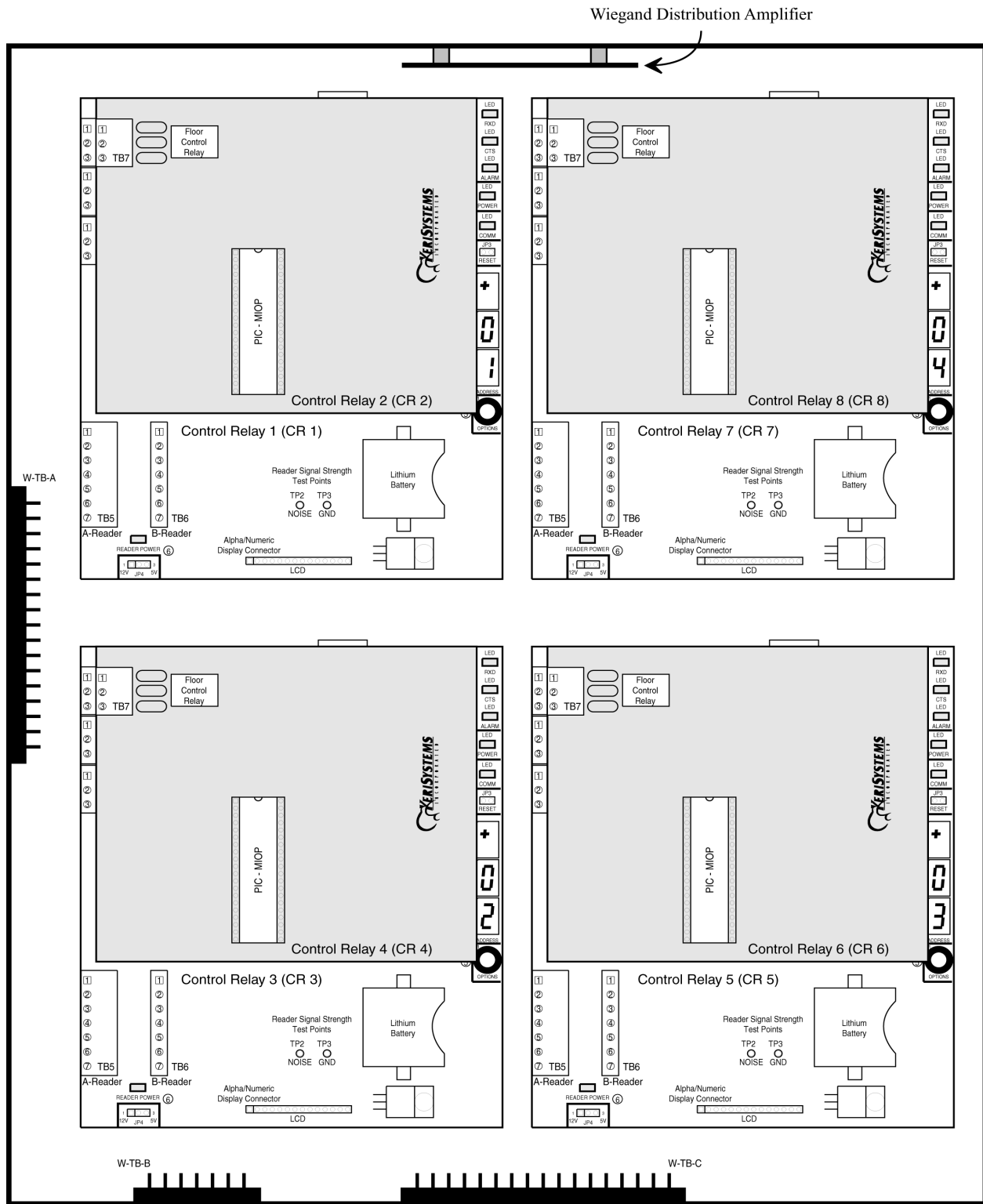

Figure 2: The SB-200 Satellite Board

# Wiegand Elevator Control Panel



**Figure 3: The LC-208W Elevator Control Panel**



# Wiegand Elevator Control Panel

## 5.1 Connecting Wires - Removing Terminal Blocks

Follow the instructions in Figure 4 when connecting wires to the controller or when removing terminal blocks from the controller.

Strip away 1/4 inch of insulation and place the wire in the appropriate slot.

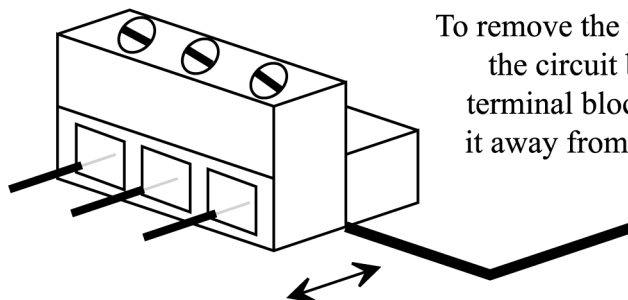

To remove the terminal block from the circuit board, grasp the terminal block and gently pull it away from the circuit board.

**Figure 4: Connecting Wires and Removing Terminal Blocks**

## 5.2 LC-202W Wiring Connections

The following connections are made to install the LS-202W Elevator Control panel (see Figure 3 on page 9).

- Floor Control Relay via W-TB-A
- RS-485 Controller Network via W-TB-B (network out) and W-TB-C (network in)
- Reader/Amplifier Daisy-Chain via TB-B (reader output) and W-TB-C (reader input)
- Earth Ground and Power via TB-C

### 5.2.1 Floor Control Relay

The Floor Control Relay is connected to the door controls at the elevator panel. If a controller has an SB-200 Satellite Board attached to control two floors, connect the lower floor to the A-Floor Control Relay and connect the higher floor to the B-Floor Control Relay. Make the floor control relay connections per the information in Table 1 and Figure 5 on page 11.

**Table 1: Floor Control Relay Connection**

LC-200W TB-3 Pin SB-200 TB-7 Pin	Description
1	Normally-Open
2	Common
3	Normally-Closed

# Wiegand Elevator Control Panel

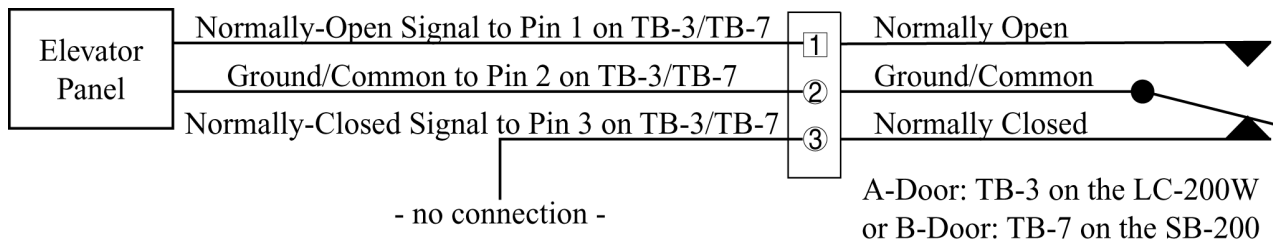

**Figure 5: Floor Control Relay Connection**

## 5.2.2 RS-485 Controller Network

All of the controllers in the elevator network communicate through an RS-485 serial communication network. Per the RS-485 industry specification, this network must be daisy-chained, with a total network cable length of no more than 4,000 feet. Make the RS-485 network connections per the information in Table 2 and Figure 6 on page 12.

*NOTE: Do **NOT** connect earth ground to the RS-485 network cable shield. The LC-200 controller automatically connects earth ground to the shield at one point on the network. This single connection minimizes the effects of ground loops that can affect controller performance.*

**Table 2: RS-485 Controller Network**

TB-1 Pin	Description
1	Tx/Rx Negative
2	Tx/Rx Positive
3	Network Cable Shield

# Wiegand Elevator Control Panel

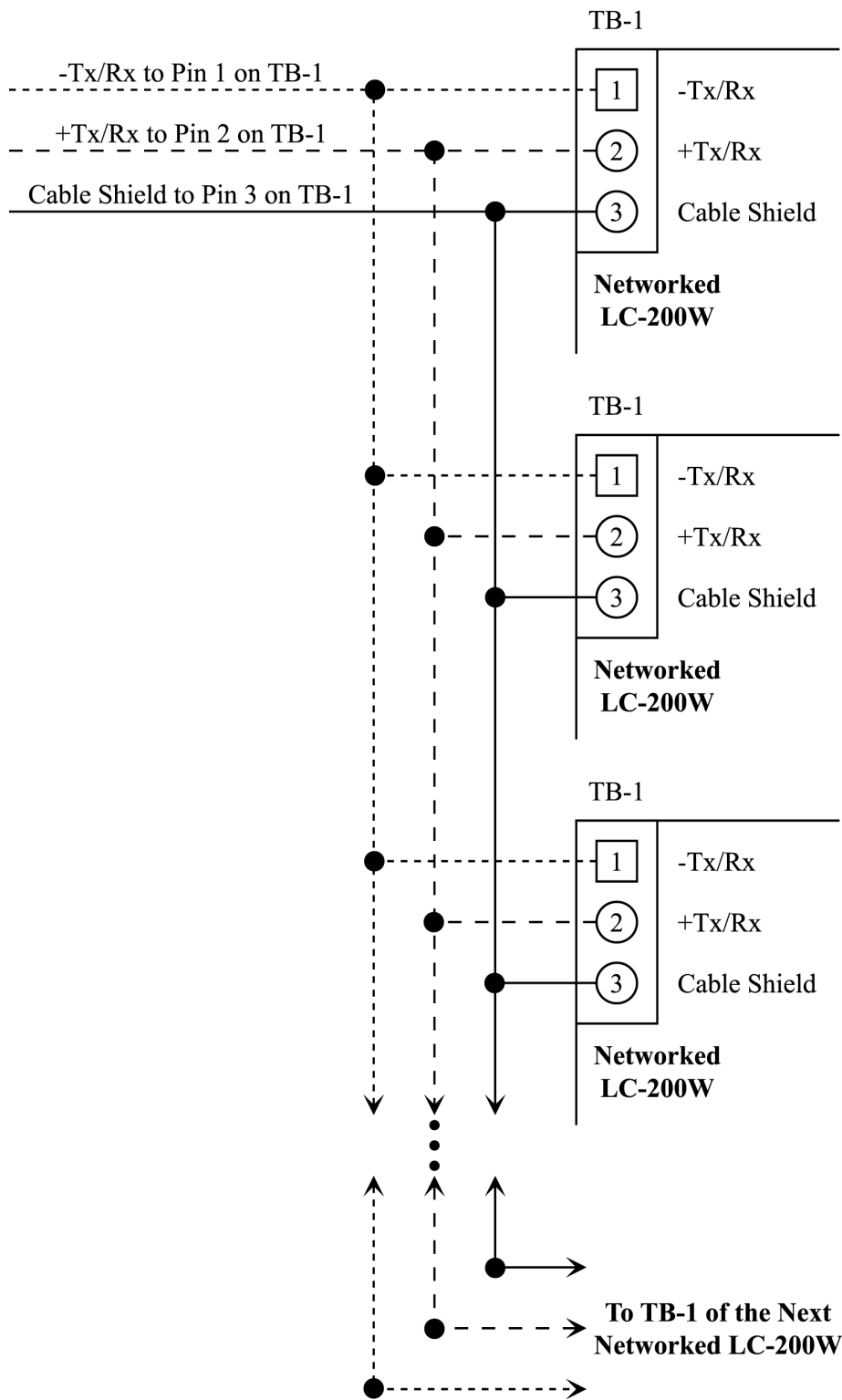
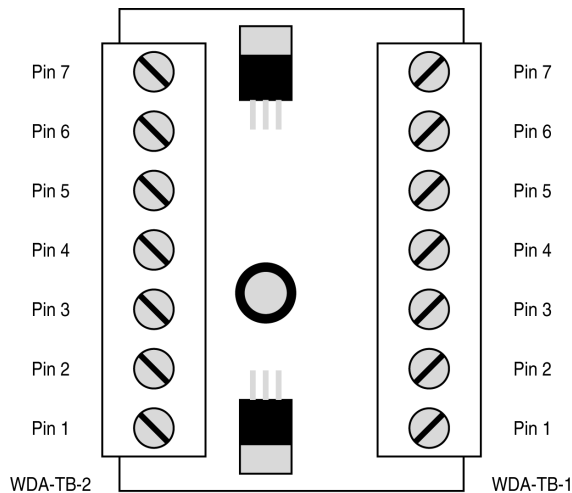

Figure 6: Daisy-Chained RS-485 Controller Network

# Wiegand Elevator Control Panel

## 5.2.3 Reader/Amplifier Daisy-Chain

One Wiegand reader is shared by all elevator control panels in an elevator control application. The Wiegand reader connections are made to the master LC-202W elevator panel, through a Wiegand Distribution Amplifier (P/N 04197-001 – see Figure 7).



**Figure 7: Wiegand Distribution Amplifier**

- Make the Wiegand reader to Distribution Amplifier connections per the information in Table 3 and Figure 8 on page 15.
- Make the Distribution Amplifier to master elevator panel connections per the information in Table 4 and Figure 8 on page 15.

**Table 3: Wiegand Reader to Distribution Amplifier**

Reader	Amplifier WDA-TB-1
Data0	Pin 1
Beeper	Pin 2
Power	Pin 3
Ground and Cable Shield	Pin 4
Green LED (Dual)	Pin 5
Red LED (Single)	Pin 6
Data1	Pin 7

# Wiegand Elevator Control Panel

**Table 4: Distribution Amplifier to Master Elevator Panel**

Amplifier WDA-TB-2	Panel TB-5
Pin 1	Pin 1
Pin 2	Pin 2
Pin 3	Pin 3
Pin 4	Pin 4
Pin 5	Pin 5
Pin 6	Pin 6
Pin 7	Pin 7

All other reader connections to the remaining LC-202W panels are made per the following rules.

1. The reader data lines must be daisy-chained from the master elevator panel to all other elevator panel data inputs – Data 0 to Pin 1 of TB-5 and TB-6 and Data 1 to Pin 7 of TB-5 and TB-6 on the LC-202W panels.
2. The reader ground line must be daisy-chained from the master elevator panel to all other elevator panel antenna grounds to provide a standard ground reference for all panels – Pin 4 of TB-5 and TB-6 on the LC-202W panels.

Make the data line daisy-chain connections per the information in Table 5 and Figure 8 on page 15.

**Table 5: Master Elevator Panel to Slave Elevator Panels**

Master Panel TB-5	Slave Panel TB-5 or TB-6
Pin 1	Pin 1
Pin 4	Pin 4
Pin 7	Pin 7

# Wiegand Elevator Control Panel

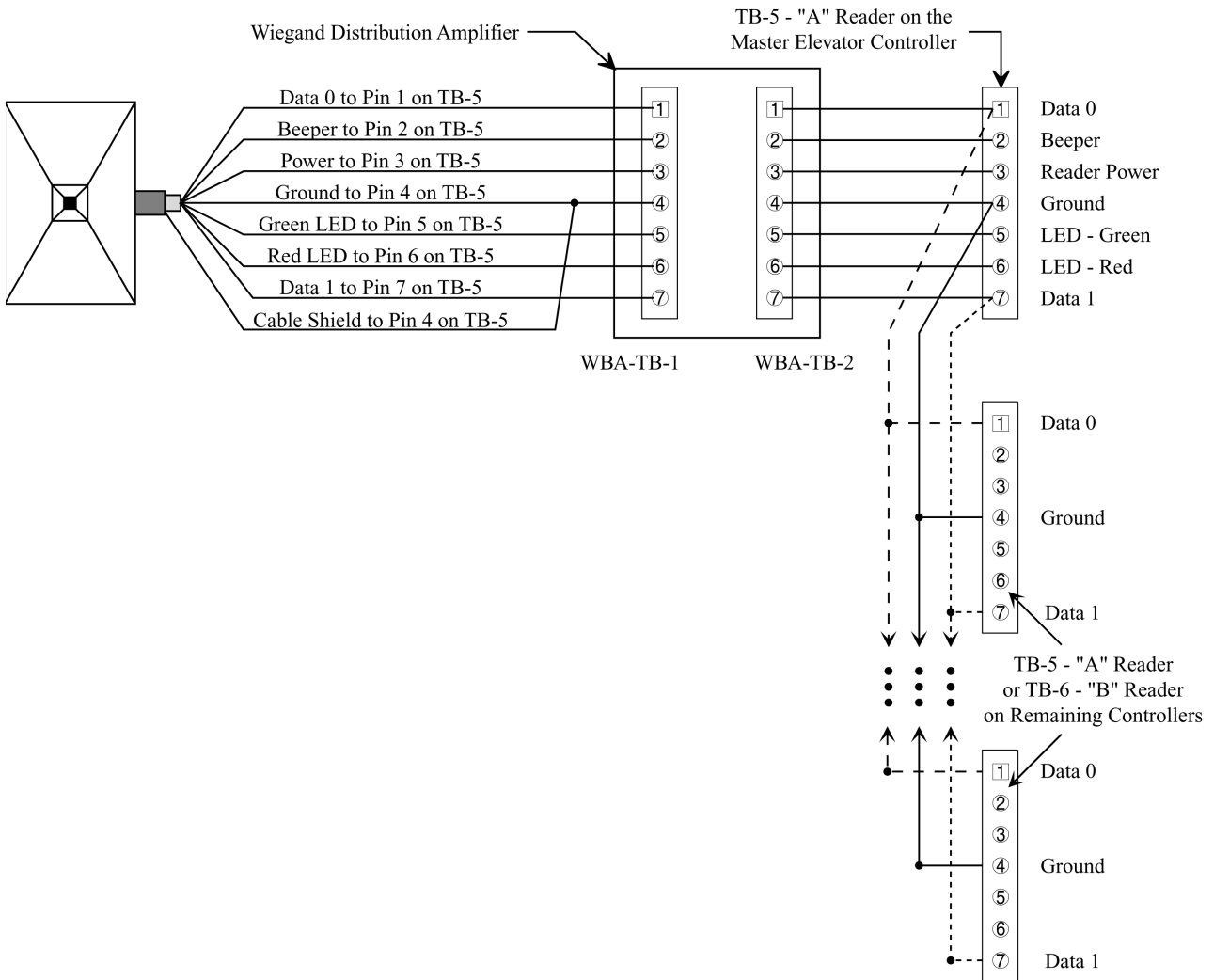

**Figure 8: Daisy-Chained Wiegand Reader Connections**

# Wiegand Elevator Control Panel

## 5.2.4 Earth Ground and Power

The LC-202W panel requires 12 VDC power at 750 mA. You must make a quality earth ground connection to the controller prior to connecting the DC power lines. The earth ground provides protection for the controller and ensures the best possible operating conditions. Possible sources for earth ground are a ground rod, a cold water pipe, a steel building frame, the electrical system ground at the breaker/fuse box, or the telephone system ground. Make the earth ground and power connections per the information in Table 6 and Figure 9.

**Table 6: Earth Ground and Power Connections**

TB-2 Pin	Description
1	+ 12 VDC Power Line
2	- 12 VDC Power Line
3	Earth Ground

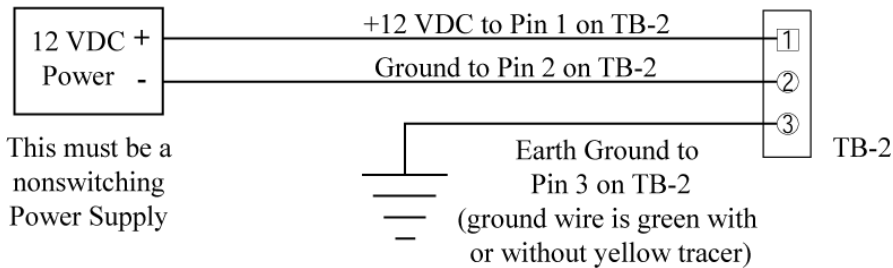

**Figure 9: Earth Ground and Power Connections**

## 5.3 LC-208W Wiring Connections

The connections between the individual LC-200W/SB-200 controllers in the LC-208W Elevator Control panel are already wired. All user connections are brought out to three terminal strips.

- one strip on the left side of the enclosure for all Floor Control Relay connections
- one strip on the bottom right of the enclosure for the controller power, the controller network daisy-chain input, and the Wiegand reader daisy-chain input connections
- one strip on the bottom left of the enclosure for the controller network daisy-chain output and the Wiegand reader daisy-chain output connections

Figure 10 on page 17 provides a diagram of the Wiegand reader terminal strip connections.

# Wiegand Elevator Control Panel

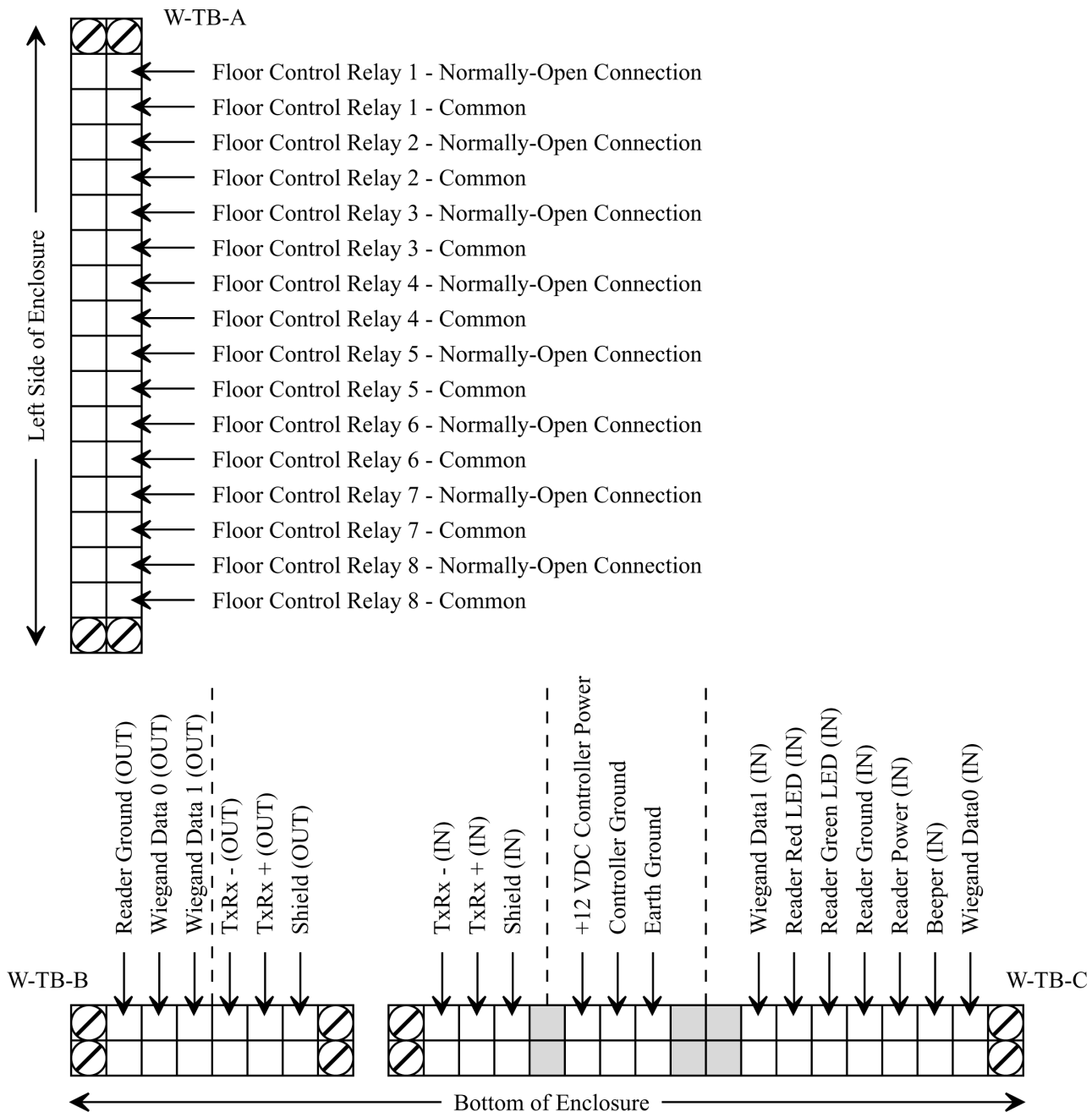

**Figure 10: LC-208W Wiegand Elevator Panel Wiring Connections**

# Wiegand Elevator Control Panel

## 5.4 Wiring Multiple Panels Together

Up to 16 floors can be controlled using a combination of LC-202Ws and LC-208Ws; the first eight floors must be controlled by an LC-208W. Any additional panel combinations of LC-208Ws and LC-202Ws can then be used to reach the desired total.

### 5.4.1 LC-208W/LC-202W Combination

Perform the following wiring instructions to accommodate an elevator application using an LC-208W and one or more LC-202W panels.

1. Make a complete set of connections to the LC-208W panel. Refer to Section 5.3 on page 16 for all connections to the LC-208W.
2. Daisy-chain the Wiegand Data0, Ground, and Data1 reader connections from W-TB-B to the LC-202W panels. Make the connections per the information in Table 7 and Figure 11 on page 19.

**Table 7: LC-208W W-TB-B to LC-202W Panel**

W-TB-B	Connection	LC-202W TB-5/TB-6
Pin 1	Reader Common	Pin 1
Pin 2	Data0	Pin 4
Pin 3	Data1	Pin 7

3. Daisy-chain the RS-485 TxRx+, TxRx-, and Shield network communication connections from the W-TB-B terminal strip on the LC-208W to each of the LC-202W panels. Make the connections per the information in Table 8 and Figure 12 on page 20.

**Table 8: LC-208W to LC-202W Panel  
RS-485 Network Communication Wiring**

W-TB-B	Connection	LC-202W TB-1
Pin 4	TxRx-	Pin 1
Pin 5	TxRx+	Pin 2
Pin 6	Shield	Pin 3

4. Refer to Section 5.2.4 on page 16 for the LC-202W panel power connections.
5. Refer to Section 5.2.1 on page 10 for the LC-202W floor relay connections.

# Wiegand Elevator Control Panel

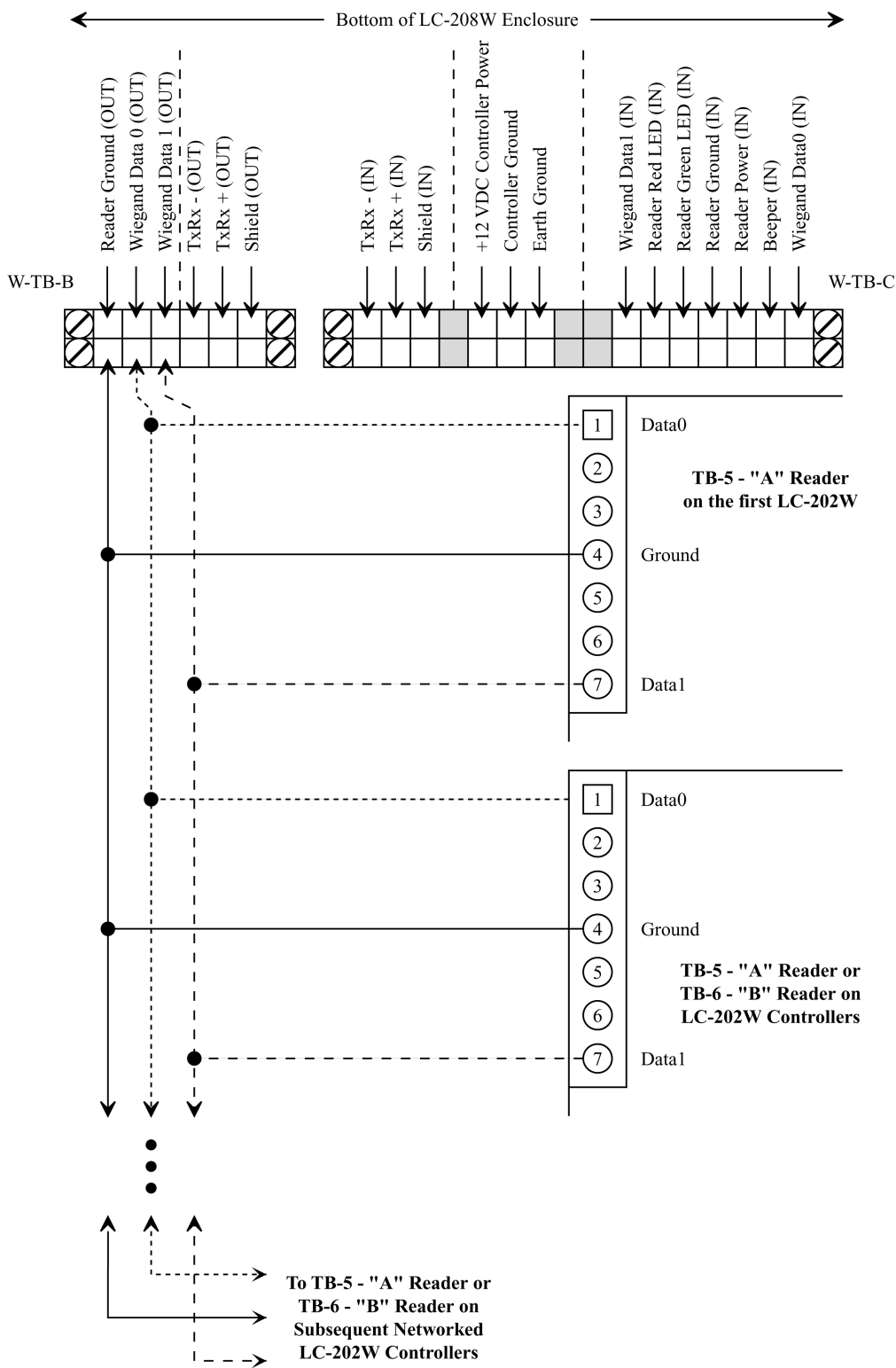

**Figure 11: LC-208W Panel to LC-202W Wiegand Reader Wiring Connections**



# Wiegand Elevator Control Panel

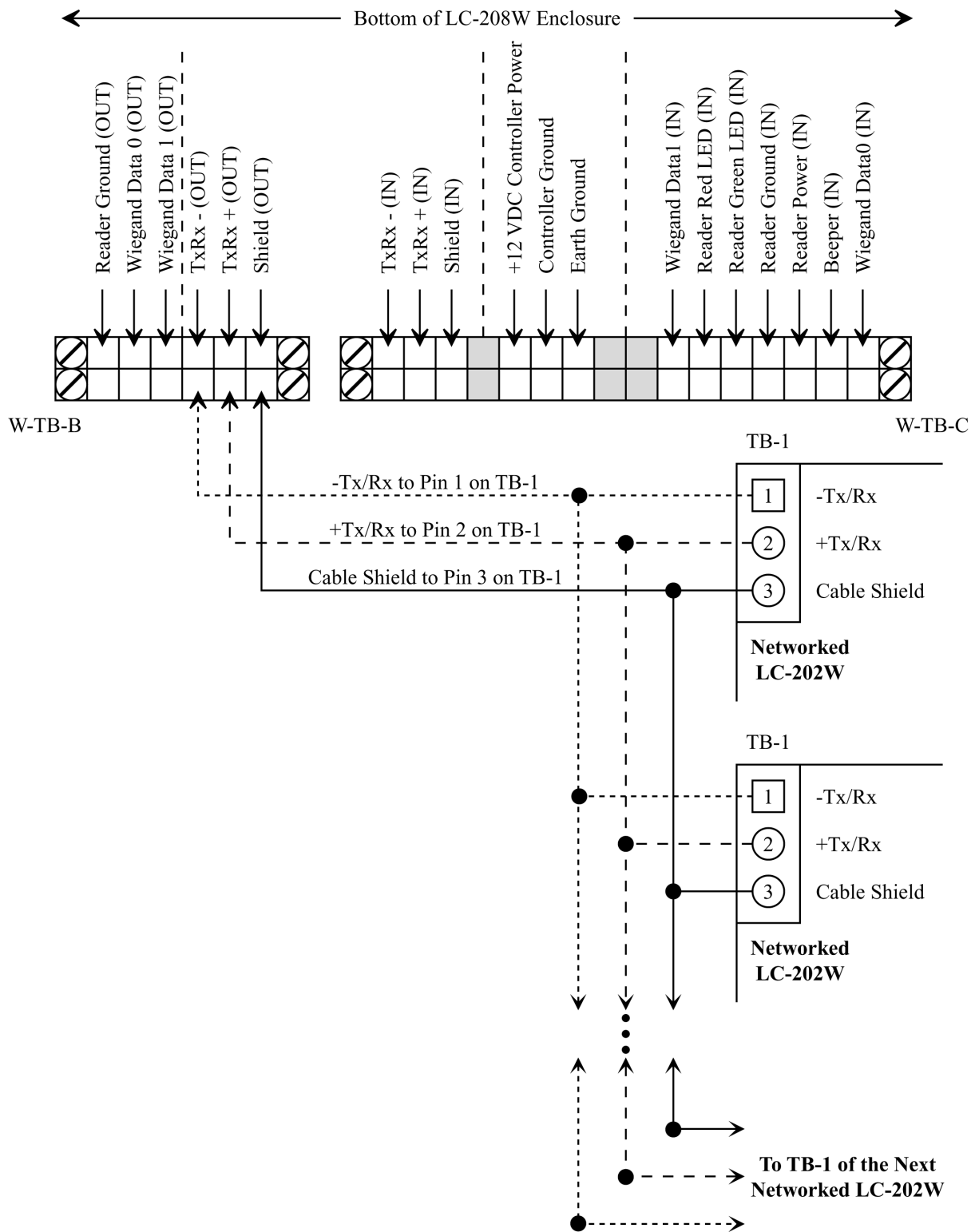

**Figure 12: LC-208W to LC-202W Panel Network Communication Wiring**

# Wiegand Elevator Control Panel

## 5.4.2 LC-208W/LC-208W Combination

Perform the following wiring instructions to accommodate an elevator application using two LC-208W panels (up to 16 floors).

1. Make a complete set of connections to the first LC-208W panel. Refer to Section 5.3 on page 16 for all connections to the LC-208W.
2. Daisy-chain the Data0, Ground, and Data1 reader connections from W-TB-B of the second LC-208W panel to W-TB-C of the first LC-208W panel. Make the connections per the information in Table 9 and Figure 13 on page 22.

**Table 9: LC-208W to LC-208W Panel Wiring Connections**

W-TB-B of Second Panel	W-TB-C of First Panel
Reader Ground (OUT)	Reader Ground (IN)
Data0 (OUT)	Data0 (IN)
Data1 (OUT)	Data1 (IN)

3. Daisy-chain the TxRx+, TxRx-, and Shield Network Communication connections from W-TB-B of the second LC-208W panel to W-TB-C of the first LC-208W panel. Make the connections per the information in Table 10 and Figure 14 on page 23.

**Table 10: LC-208W to LC-208W Panel Network Communication Wiring**

W-TB-B of Second Panel	W-TB-C of First Panel
TxRx - (OUT)	TxRx - (IN)
TxRx + (OUT)	TxRx + (IN)
Shield (OUT)	Shield (IN)

4. The floor/relay connections for the second LC-208W are made according to the floor/panel association. Refer to Section 5.3 on page 16 for all floor/relay connections to the LC-208W. Power connections are made per the instructions in Section 5.2.4 on page 16.



# Wiegand Elevator Control Panel

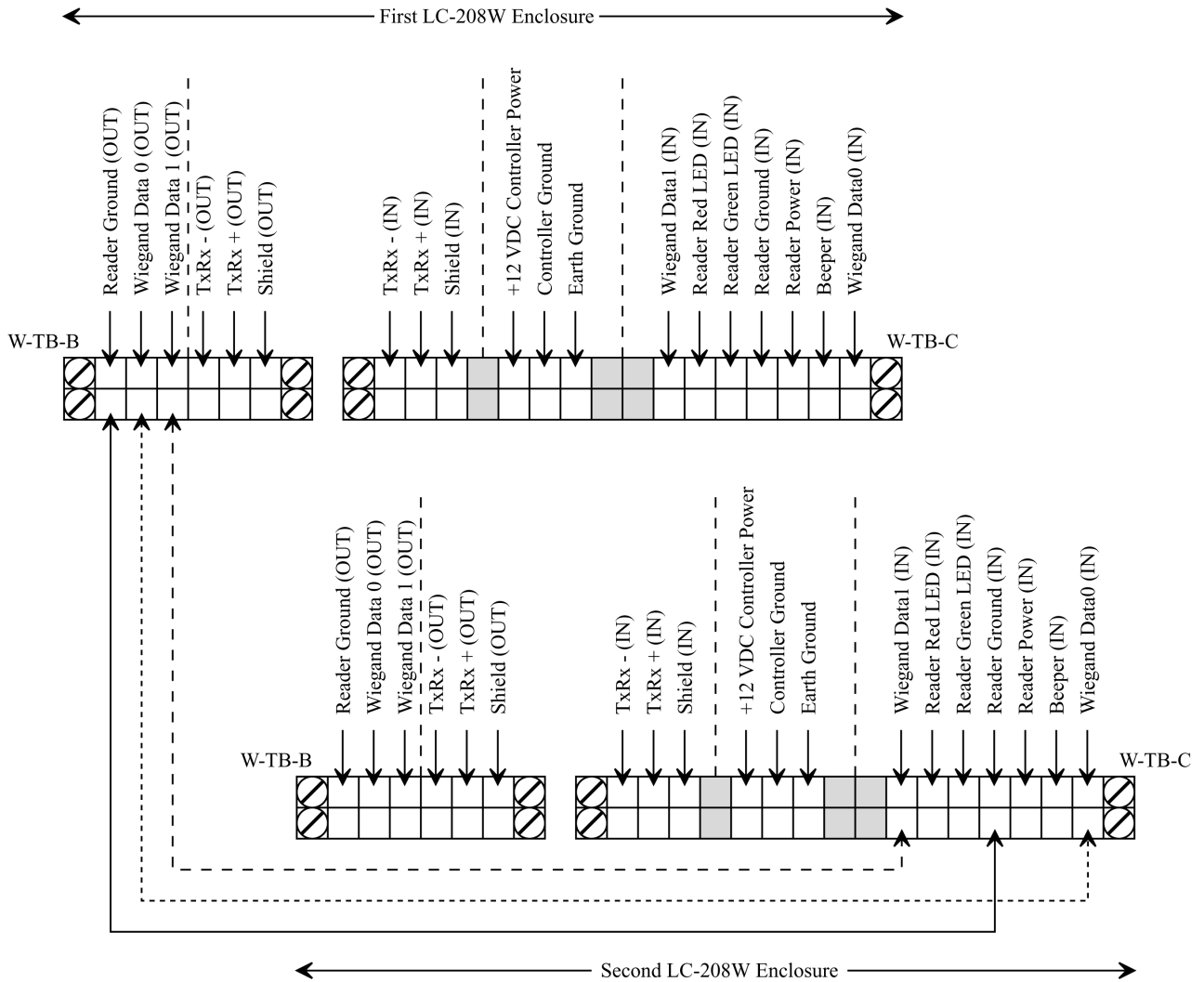

**Figure 13: LC-208W to LC-208W Reader Wiring Connections**

# Wiegand Elevator Control Panel

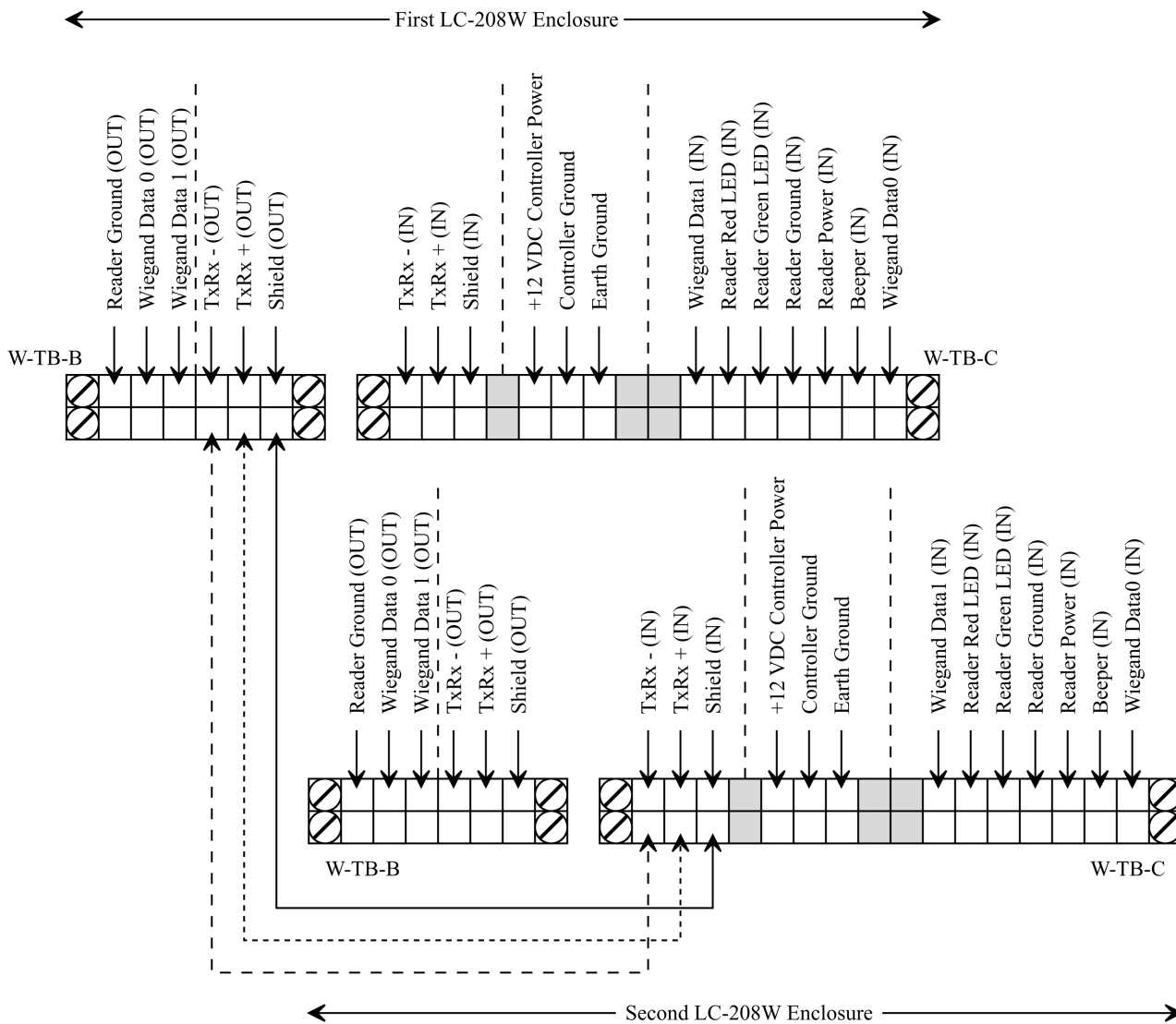

**Figure 14: LC-208W to LC-208W Panel Communication Wiring**

*NOTE: The floor/panel numbering for the second LC-208W will be from 9 to 16 (not 1 to 8 as shown in Figure 10 on page 17). Based on the way these panels are wired, the top left controller in the first panel (see Figure 3 on page 9) must be the master controller, and must be assigned address 1. All other controllers, including the top left controller in the second panel must have a unique address (typically addresses 5 through 8).*

# Wiegand Elevator Control Panel

## 5.5 Host Computer Wiring Connections

The wiring connections between the Host Computer and the access control/elevator control network are thoroughly described in the PXL-250/SB-293 Technical Reference Manual (P/N 01836-003) and the PXL-250 Quick Start Guide (P/N 01835-002). Please refer to these documents for information regarding host computer/network connections.

## 6.0 Elevator Reader Responses to Access Control Events

During day-to-day activity, the reader in the elevator car will respond to access control events in a specific manner. Refer to Table 11 for a summary of the Reader's LED and beeper actions during access control events.

**Table 11: Reader Responses to Access Control Events**

Event	LED Status	Beeper Status
waiting for card presentation	displays a steady Amber LED	silent
upon card presentation	flashes a Green LED	one short beep