

MS-1400 Keri Keys Receiver

Installation Guide

- Section 1 - Keri Keys Receiver Configuration
- Section 2 - Specifications
- Section 3 - Two Channel Operation Wiring
- Section 4 - NXT-RIM Wiring
- Sections 5, 6, and 7 - Housing, Mounting, and Receiver Read Range
- Section 8 - LED and Beeper Functions
- Section 9 - Keri Keys - Key Fob Transmitter
- Section 10 - Contact Keri Systems

Keri System’s Keri Keys Receiver is a two-channel output receiver capable of outputting two separate channels based upon which button is pushed on the clicker/transmitter. The receiver outputs data in a format compatible with Keri Systems MS series readers as used with the PXL-500P Tiger Controllers and is capable of operating reliably at 300 feet using the receiver’s built-in antenna. Greater distance can be achieved with use of an external antenna.

1.0 Keri Keys Receiver Configuration

The diagram below shows the configuration of the receiver board.

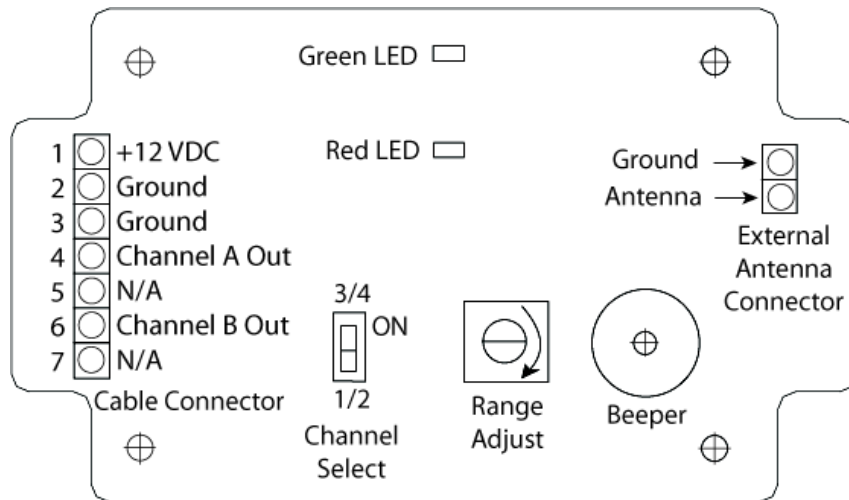

Figure 1: Clicker Receiver

1.1 Channel Select Configuration

By using two receivers you can use the four button clicker to operate up to four entrances. Setting the channel select switch to 1/2 will allow it to operate with clicker buttons 1 and 2. Setting the channel select switch to 3/4 will allow use of clicker buttons 3 and 4 (see Figure 1 for location of the channel select switch).

The chart below shows the function of each of the 4 clicker buttons.

Receiver Channel	Channel Select Switch (1/2)	Channel Select Switch (3/4)
A	Clicker Button 1	Clicker Button 3
B	Clicker Button 2	Clicker Button 4

NOTE: For single button clickers the switch must be set to 1/2.

MS-1400 Keri Keys Receiver

Installation Guide

2.0 Specifications

Clicker Receiver Dimensions (Enclosure)

- 7.24 inches high by 3.75 inches wide (at the widest point) by 2.30 inches deep
- 18.39 cm high by 9.52 cm wide by 5.84 cm deep

Power/Current Requirements

- less than 100 mA (allows it to be powered from the PXL-500 the same as other MS series readers)

Operating Temperature/Humidity Range

- -20°F to 140°F (-29°C to 60°C)
- 0% to 90% Relative Humidity, non-condensing

Cable Requirements

One PXL:

- 4 conductor, shielded cable (such as Belden 9534) up to 500 feet from the host controller

2 PXLs:

- 3 conductor, shielded cable up to 500 feet from the first controller
- 2 conductor, shielded cable up to 500 feet from the second controller

MS-1400 Keri Keys Receiver

Installation Guide

3.0 Two Channel Operation Wiring

This receiver is designed to output data on two separate channels. This allows one receiver to control two entrances when using the four button clicker.

NOTE: For Single Channel Operation, connect the Channel A output only.

3.1 One PXL-500P

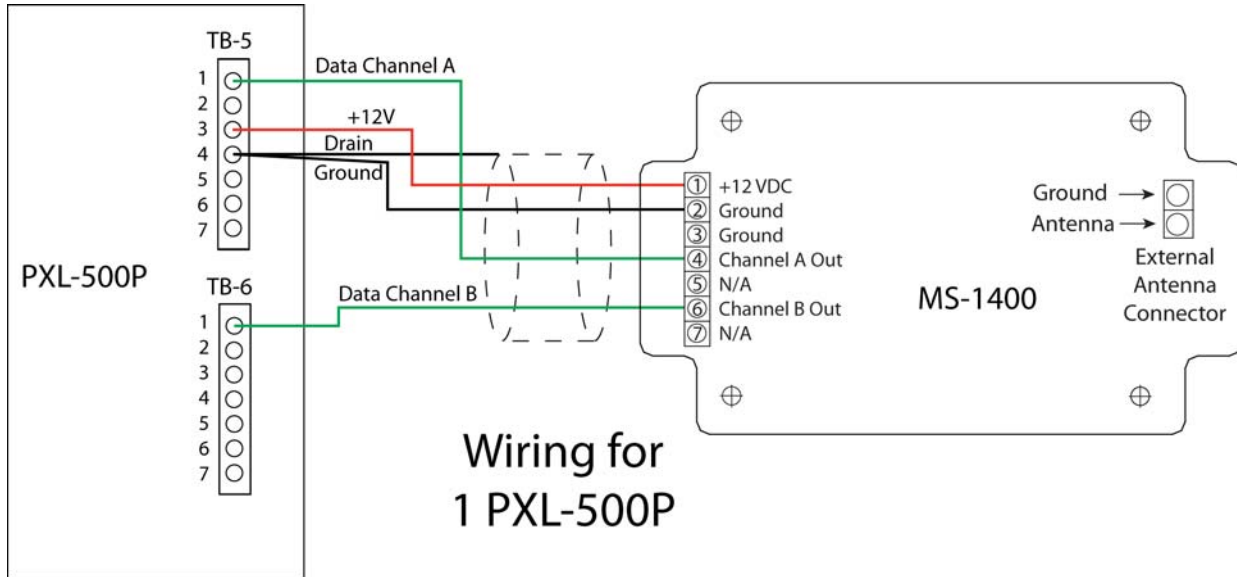

Figure 2: MS-1400 Keri Keys Wiring - 1 PXL-500P

3.2 Two PXL-500Ps

NOTE: When connecting the receiver to two PXLs, connect the 12VDC from only one PXL-500P.

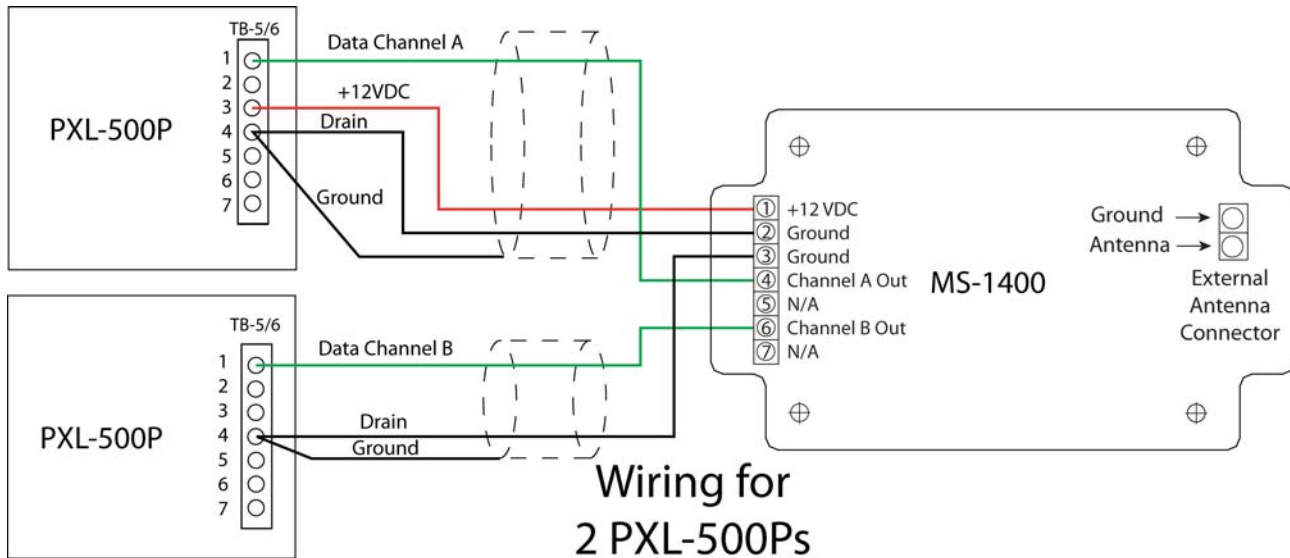

Figure 3: MS-1400 Keri Keys Wiring - 2 PXL-500Ps

MS-1400 Keri Keys Receiver Installation Guide

4.0 NXT-RIM Wiring

If an NXT-RIM is needed to connect the receiver to an NXT reader, use the following information. For information on connecting the NXT-RIM to a reader see the *NXT Reader Interface Module Installation Guide* (P/N 02501-001).

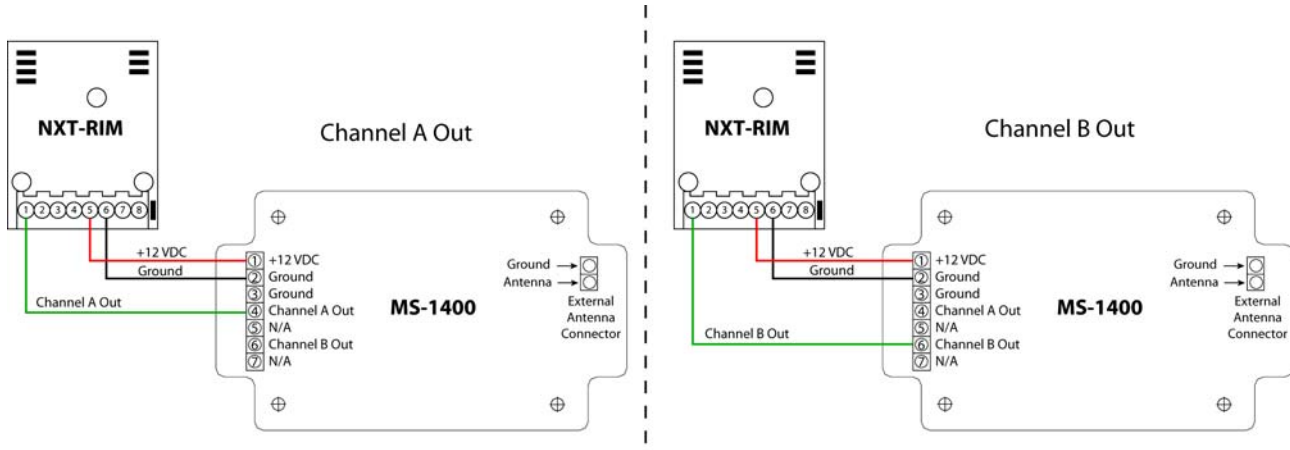

Figure 4: MS-1400 Keri Keys Wiring - NXT-RIM

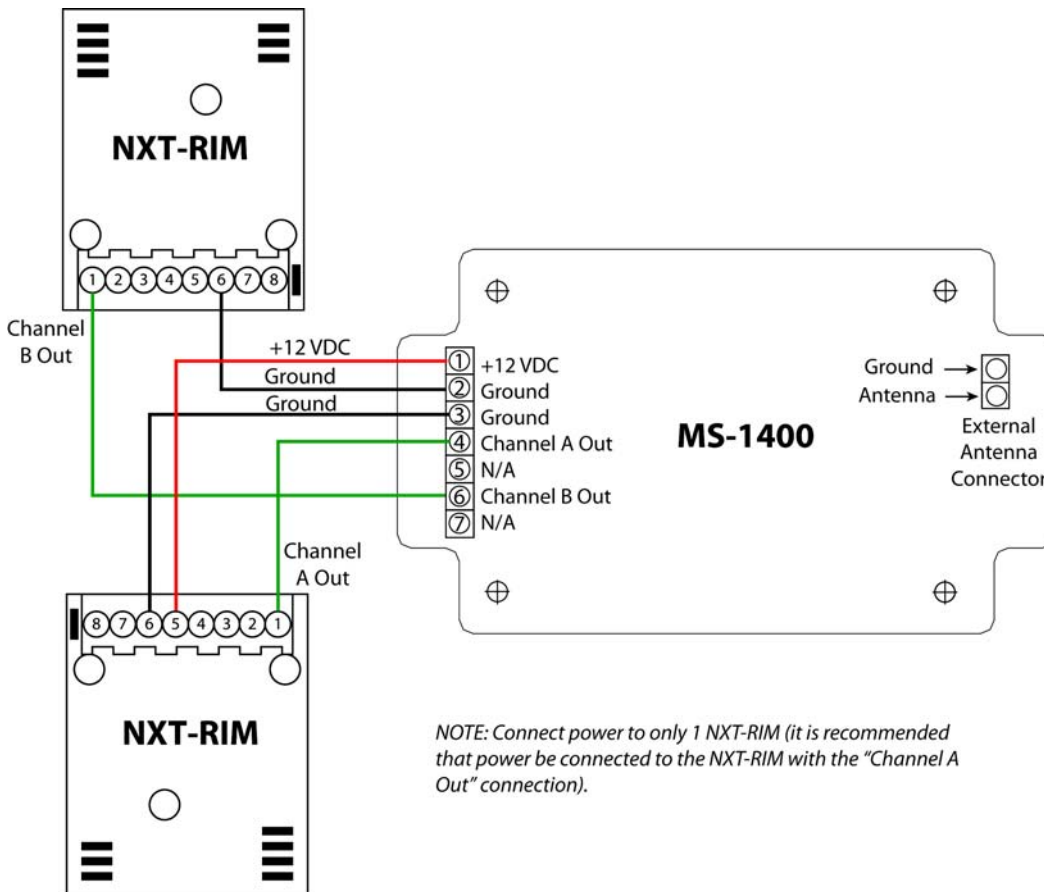

Figure 5: MS-1400 Keri Keys Wiring - 2 NXT-RIMs

MS-1400 Keri Keys Receiver

Installation Guide

5.0 Housing

The receiver is housed in an IP67 rated enclosure, which is dust and moisture resistant. It can be mounted outdoors on fences, buildings, etc.



NOTE: When installing the lid, care must be taken to insure the gasket fits properly in the correct slot. Failure to do this, will allow water to enter the box.

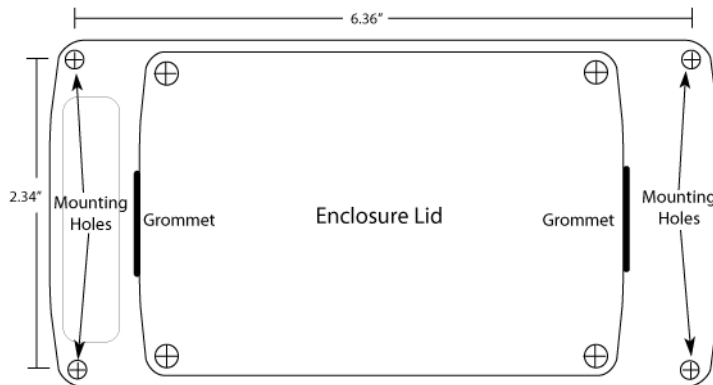

Figure 6: Clicker Receiver Enclosure

6.0 Mounting

The receiver should be mounted in an area that is relatively free of large metal obstructions such as ductwork, appliances, wire lath, etc. The enclosure can be attached to a wall, fence¹, etc. with the 4 mounting holes provided on the base of the unit.

The receiver comes mounted on the lid of the enclosure. This allows ample space for cabling, conduit entrance, etc. If required, the receiver may be mounted to the base of the enclosure. To insert the 4 conductor cable into the enclosure, take a small screwdriver, or other small sharp object and push it through the grommet opening. Continue pushing until it pierces the interior of the grommet. Remove the screwdriver and insert the cable through the grommet.

NOTE: It is recommended to attach a tie wrap around the cable at the grommet and if more strain relief is needed mount a “P” clamp to a nearby boss using a #4 self tapping screw.

7.0 Receiver Read Range

To insure the receiver is located in a good coverage area when first installing:

1. Take a clicker to the furthest point where coverage is desired. Depress the appropriate button twice and have someone watch the LEDs. Both the Red and Green LEDs will blink off momentarily if you are in range.
2. If the receiver range is greater than desired, proceed as above and have someone turn the Range Adjustment control counter clockwise until the LEDs do not respond. Then turn clockwise by a degree or two. If the LEDs now respond, the receiver range has been set to the location desired.
3. If the receiver is mounted in a metal housing, or in some other location that adversely affects the read range, an external antenna will need to be mounted. To add an external antenna, open the grommet on the top of the enclosure as previously done for the data cable.
4. The coaxial cable is passed through this and connected to the external antenna terminal at the top of the receiver board. Make sure to connect the coax shield to the “GND” connector and the center conductor to the “ANT.”
5. Mount the antenna in a location that allows the desired read range.

1. A metal fence will require the use of an external antenna.

MS-1400 Keri Keys Receiver

Installation Guide

8.0 LED and Beeper Functions

The following tables detail the LED and beeper indications on the receiver

Green LED	Indication
On	Receiver has power and has passed self tests.
Off	Receiver is not powered or failed to power up successfully.
LED blinks off momentarily	Receiver has received a clicker packet. It may or may not be sent up the data line, depending on clicker button pressed and channel selection switch position.

Red LED	Indication
On	Normal operation.
LED blinks off momentarily	Receiver has received a clicker packet. Clicker button matches setting of the channel selection switch, and data has been sent on the appropriate data output channel.

Beeper	Indication
Off	Normal operation.
Short audio burst	Receiver has received a clicker packet. Clicker button matches setting of the channel selection switch, and data has been sent on the appropriate data output channel.

MS-1400 Keri Keys Receiver

Installation Guide

9.0 Keri Keys - Key Fob Transmitter

The Keri Keys Receiver is to be used with the TM-10 or TM-40 key fob transmitter.

TM-10, TM-10MS, TM-10FW

TM-40, TM-40MS, TM-40FW

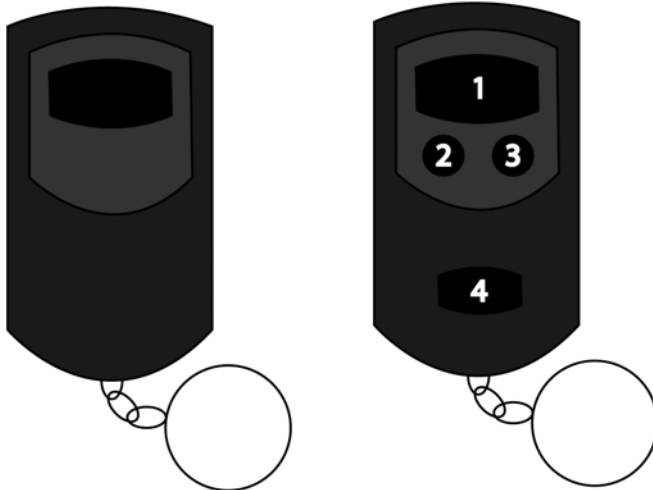

Figure 7: TM-10 and TM-40 Key Fob Transmitter

10.0 Contact Keri Systems

Keri USA	Keri UK, Ireland, Europe
2305 Bering Drive San Jose, CA 95131	Unit 17 Park Farm Industrial Estate Ermine Street Buntingford Herts SG9 9AZ UK
Telephone: (800) 260-5265 (408) 435-8400	Telephone: + 44 (0) 1763 273 243
Fax: (408) 577-1792	Fax: + 44 (0) 1763 274 106
Web: www.kerisys.com	Web: www.kerisystems.co.uk
E-mail: sales@kerisys.com techsupport@kerisys.com	E-mail: sales@kerisystems.co.uk tech-support@kerisystems.co.uk

End of document.