

NXT-1R/-3R/-5R Reader

Installation Guide

Section 1 – Wiring and Layout Diagrams
 Section 2 – Specifications and Cable Options
 Section 3 – Keri Contact Information

1.0 Wiring and Layout Diagrams

1.1 NXT-1R/-3R/-5R Readers

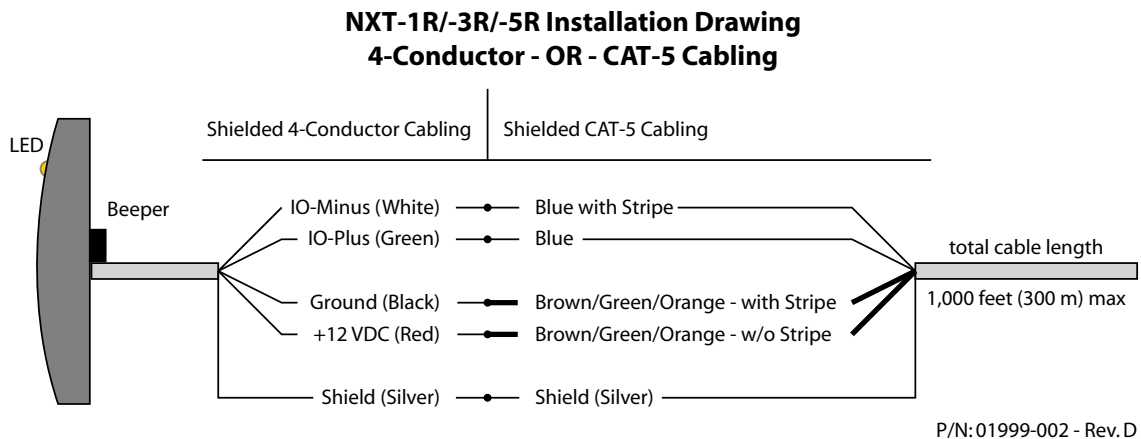

- This equipment has been tested and found to comply with the limits for a Class A digital device, pursuant to Part 15 of the FCC Rules. These limits are designed to provide reasonable protection against harmful interference when the equipment is operated in a commercial environment. This equipment generates, uses, and can radiate radio frequency energy and, if not installed and used in accordance with the instruction manual, may cause harmful interference to radio communications. Operation of this equipment in a residential area is likely to cause harmful interference in which case the user will be required to correct the interference at his own expense.
- Changes to this equipment not expressly approved by Keri Systems, Inc. may void FCC certification and the user’s authority to operate this equipment.
- Operation is subject to the following two conditions: (1) this device may not cause interference, and (2) this device must accept any interference, including interference that may cause undesired operation of the device.

2.0 Specifications

2.1 NXT-Reader Dimensions

- NXT-1R Euro Mount Prox Reader
 - 3.25 inches tall by 3.25 inches wide by 0.5625 inches deep, not including wiring connectors
 - 8.25 cm by 8.25 cm by 1.43 cm
- NXT-3R Mullion Reader
 - 3.75 inches tall by 1.625 inches wide by 0.50 inches deep
 - 9.52 cm by 4.13 cm by 1.27 cm
- NXT-5R Wall Switch Reader
 - 4.50 inches tall by 3.00 inches wide by 0.625 inches deep, not including wiring connectors
 - 11.43 cm by 7.62 cm by 1.59 cm

2.2 Power/Current Requirements

- 10 to 14 VDC @ 120 mA (maximum current draw at 12 VDC)

2.3 Operating Conditions

- -40°F to 150°F (-40°C to 65°C) – 0% to 90% Relative Humidity, non-condensing

NXT-1R/-3R/-5R Reader

Installation Guide

2.4 Cable Options

RS-485 bus runs can daisy-chain together an NXT-4x4 and NXT-Reader on one line. The total cable run distance should be less than 500 feet from the NXT controller for runs with 4x4s and less than 1,000 feet for Reader-only runs.

*NOTE: Cable resistance causes a drop in voltage at the end of long cable runs. Ensure the appropriate power and current for your device is available **at the device** at the end of the cable run. Heavier gauge cable reduces this affect.*

NOTE: Keri does not recommend hot-plugging a Reader, RIM, or 4x4 into an NXT controller. Remove power from the controller prior to connecting these devices.

Table 1: Reader and 4x4 Cable Options

Connection Type	Total Run Length	Shielded, Stranded, 2 Twisted-Pair ^a		CAT-5 ^b	Shielded, Stranded, 4-Conductor ^c	
		AWG	Suggest		AWG	Suggest
RS-485 bus from NXT-2D/-4D to NXT-4x4 only	up to 500 feet	18 - Data plus 4x4 Power 22 - Data only	Belden 8723	unshielded	18 - Data plus 4x4 Power 22 - Data only	Windy City: 414302-S West Penn: 244 Tappan: 1880AB4M-CM
RS-485 bus from NXT-2D/-4D to NXT-4x4 and NXT Readers	up to 500 feet	18 - Data plus 4x4 Power 22 - Data only	Belden 8723	shielded	18 - Data plus 4x4 Power 22 - Data only	Windy City: 414302-S West Penn: 244 Tappan: 1880AB4M-CM
RS-485 bus from NXT-2D/-4D to NXT Readers only	up to 1,000 feet	22 for Data	Belden 8723	shielded	22 for Data	Windy City: 416303-S West Penn: 241 Tappan: 2280AB4M-CM

- a. Keri recommends this cable type for best system performance.
- b. Keri's preferred low-cost option. Keri has no suggested vendor for this type of cable.
- c. Use care when routing this type of cable as it can make the system more susceptible to EMI.

NXT-1R/-3R/-5R Reader Installation Guide

3.0 Contact Keri Systems

Keri USA	Keri UK, Ireland, Europe
2305 Bering Drive San Jose, CA 95131	Unit 17 Park Farm Industrial Estate Ermine Street Buntingford Herts SG9 9AZ UK
Telephone: (800) 260-5265 (408) 435-8400	Telephone: + 44 (0) 1763 273 243
Fax: (408) 577-1792	Fax: + 44 (0) 1763 274 106
Web: www.kerisys.com	Web: www.kerisystems.co.uk
E-mail: sales@kerisys.com techsupport@kerisys.com	E-mail: sales@kerisystems.co.uk tech-support@kerisystems.co.uk

End of document.