

PXL-250 Quick Reference

This Quick Reference is designed for the experienced installer as a quick reference while installing to ensure all connections are made properly.

The Quick Reference is designed as a checklist of sorts where you may check off as each installation procedure is completed. Additional information is given for those who need to be reminded of what is performed during that part of the installation. For detailed information on installing the PXL-250 Tiger Controller, see the [PXL-250 Quick Start Guide](#) (P/N 01835-002) or the [PXL-250/SB-293 Technical Reference Manual](#) (P/N 01836-004).

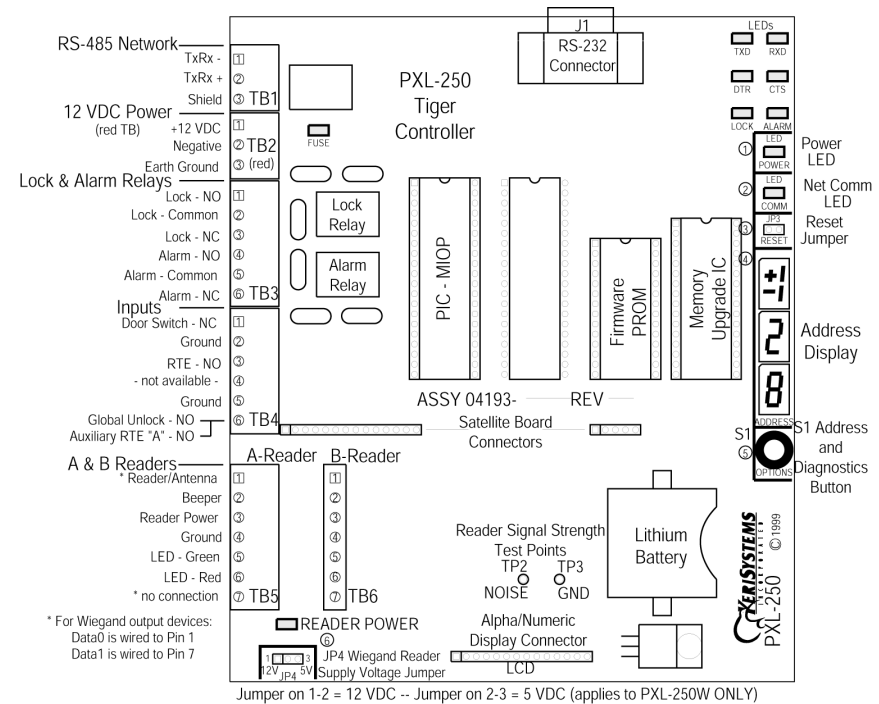

Figure 1: PXL-250 Board

1.0 PXL-250: Before Turning Power ON

- ☐ Verify 12 VDC is supplied to the controller.
 1. Verify the power supply is the correct voltage by first setting the tester to AC and checking the voltage the power supply. If it reads over 1 volt AC, then you will need to use a different power supply (preferably linear).
 2. Set the DVM to a DC volt scale capable of reading 12 VDC.
 3. Turn the power supply ON.
 4. Place the Red DVM lead on the power supply's terminal block output - Pin 1. Place the Black DVM lead on the power supply's terminal block output - Pin 2. Check the DVM reading. It should read between +12 VDC to +14 VDC.
 5. If the DVM does not read between +12 VDC to +14 VDC, verify the power supply is of the correct voltage (see step 1 above), verify the cable length does not exceed 200 feet, and verify the cable gauge is AWG 18. This problem must be corrected before power can be supplied to the controller.
 6. Turn the power supply OFF.
 7. Connect the power supply's terminal block output to the TB-2 connector on the PXL-250 controller.
 8. The controller is now ready to be powered ON.

NOTE: On long power cable runs, keep in mind the resistance in the cable itself causes a drop in voltage at the end of the run. The power supply must be able to account for this voltage drop.

- ☐ Verify all wiring connections are secure and are made to the correct Terminal Block pins.
- ☐ Verify a good earth ground has been connected to TB-2, pin 3.
- ☐ If the controller is not using a door contact switch, verify a door switch input jumper is connected between TB-4, pins 1 and 2.
- ☐ Verify transient suppression has been installed on all electrical devices connected to a controller's outputs.

- ☐ If this is a PXL-250W Wiegand controller, verify the JP4 Wiegand reader voltage supply jumper is set correctly. The default position for the JP4 jumper is set at 5 VDC (jumper across pins 2-3). If your Wiegand compatible reader requires 12 VDC, move the jumper on JP4 from pins 2-3 to pins 1-2 while the power is off. When 12 VDC power is being supplied to the reader, the POWER READER warning LED (located above the JP4 jumper) turns red. **If 12 VDC is applied to a 5 VDC reader, the reader may be damaged. Keri Systems, Inc. cannot be held responsible for a reader damaged in this way.**

NOTE: Early revisions of the surface mount PXL-250W mislabeled the JP4 jumper as JP5. All instructions for the JP4 jumper apply to the jumper labeled as JP5 (see Figure 1 for the location of the jumper).

2.0 Powering the controller for the first time:

- ☐ Reset the controller's RAM.
 1. Turn the controller's power off.
 2. On the controller, insert a jumper across pins 1 and 2 of JP3.
 3. Hold the S1 Address and Diagnostics Button down and turn the controller's power on. The beeper for the reader attached to the controller will beep as power comes on followed by a beep-beep indicating the controller's firmware has reset the controller's RAM.
 4. Release S1. If the optional Alpha/Numeric Display has been installed, it will display a "SYSTEM RESET" message. Turn system power off and remove the jumper on JP3. The controller is ready.
- ☐ Set the controller's address.
 1. Turn the controller's power off. Verify JP3 is not installed (if JP3 is installed, the controller RAM will be reset when the power is turned on).
 2. Hold the S1 Address and Diagnostics Button down and turn the controller's power on. The beeper for the reader attached to the controller will beep as power comes on followed by a beep-beep indicating the controller's firmware has entered the address setting mode.
 3. Release S1. The address display LEDs then become active and the controller's address can be set. If an Alpha/Numeric Display is connected to the controller, "ADDRESS CHANGE" will appear on the display. The address range is from 1 to 128 (the Master Controller must be set to address 1).
 4. Quickly double clicking S1 toggles between increasing and decreasing the controller address. The top LED character will display either a "+" or a "-" to show which direction is active. A single click of S1 changes the controller address by 1. If you're at address 128, a +1 click will roll the address over to 1; conversely, if you're at address 1 a -1 click will roll the address over to 128. Holding S1 down rapidly scrolls through the addresses.
 5. After the new address has been set, you must wait approximately 30 seconds. There is a timer in the controller's firmware that assumes that after 30 seconds of inactivity (no address clicks), the entered address is the desired address for that controller. When the 30-second timer expires, there will be a beep-beep indicating the controller has recognized and accepted the new address and the address LEDs will turn off. If an Alpha/Numeric Display is connected to the controller, "UNIT ##" will appear on the display (where ## is the controller's address).

2.1 Recommended Power Supplies

Manufacturer	Description	Model Number	Keri Systems Part Number
ESD	12 Volt – 2 Amp	LP-2	KPS-5
ESD	24 Volt – 2 Amp	LP-2	KPS-6 ^a
ESD	12 Volt – 10 Amp	LP-10	KPS-11
Power One	12 Volt – 3.4 Amp	HC12-3.4A	n/a
Power One	12 Volt – 1.7 Amp	HB12-1.7A	n/a
Golden Pacific	12 Volt – 1.2 Amp	PD-1212AR	KPS-7

- a. For use with the MS-9000 Proximity Reader.

2.2 Current Draw

- maximum current draw 270 mA for a controller plus reader current draw (refer to Table 1 for Reader current draw)
- 120 mA max for a PXL-250 Controller
- 150 mA max for an SB-293 Satellite Board

Reader Type					
	MS-3000	MS-4000	MS-5000	MS-7000	MS-9000
Current Draw	50 mA	50 mA	100 mA	200 mA	200 mA

NOTE: If an electronic locking device (such as a magnetic lock, door strike, or similar device) is to be driven by the same power supply as the PXL-250 controller, please ensure the power supply provides enough current to drive every device connected to that supply plus an adequate safety margin. AC power cannot be used.

2.3 Cable Requirements

RS-232 Serial Cable

- four conductor, shielded, stranded, AWG 24 wire (Belden 9534 or a larger gauge)
- 50 feet maximum length (per RS-232 industry specification - greater lengths are not recommended)

RS-485 Network Cable

- one twisted, shielded pair of conductors, stranded, AWG 24 wire (Belden 9501 or a larger gauge)
- 4,000 feet total network length (per RS-485 industry specification)
- extended network configurations are possible – refer to the [Network Wiring](#) Application Note (P/N 01824-002) for extended network configurations of up to 5,000 feet per star line and 16,000 feet total network length

Input Power

- two conductor, stranded, AWG 18 wire (Belden 8461 or a larger gauge)
- 200 foot maximum length for systems using an SB-293 with two readers

NOTE: On long power cable runs, the cable resistance causes a drop in voltage at the end of the cable run. Be sure your power supply does provide 12 VDC at the end of the cable run.

Earth Ground

- Single conductor, AWG 18 wire (or a larger gauge)¹

3.0 Wiring Connections

3.1 Proximity Reader Connection

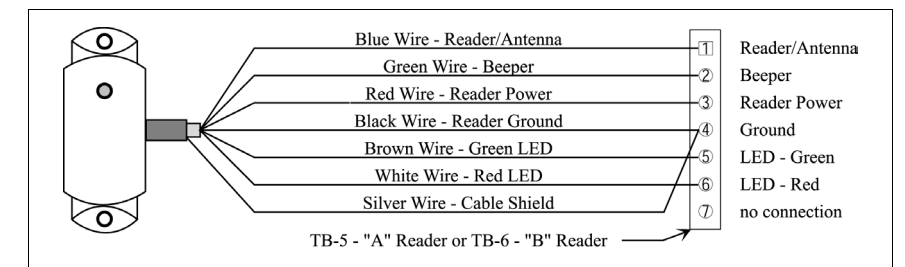

Figure 2: Proximity Reader Connection

1. Ground wire is green with yellow tracer.

3.2 Wiegand Compatible Reader Connection

NOTE: The wire colors called out in Figure 3 are industry standard wire colors. However, some manufacturers may not follow these industry standard designations. Before installation, please refer to the Wiegand device's manual to see if the device's wire colors follow the industry standard. If not, then match the wire's purpose to the callouts in Figure 3 before installation.

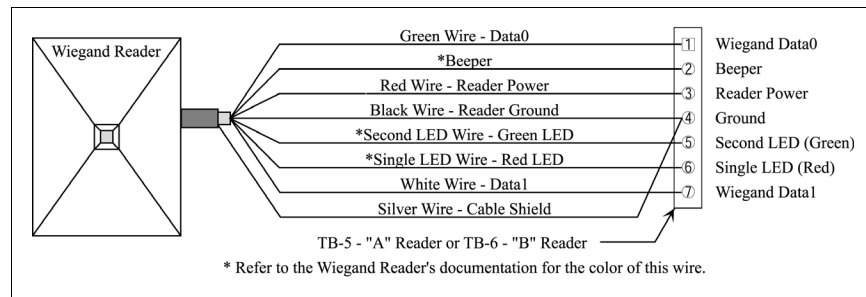

Figure 3: Wiegand Compatible Reader Connection

3.3 Reader Responses to Access Control Events

Event	Reader's LED Status	Reader's Beeper Status
waiting for an event	displays a steady Amber LED	silent
access granted	displays a Green LED until the door is closed or the door unlock time is reached	one long Beep
access denied	flashes a Red LED	one short Beep
door alarm	flashing Red LED for the duration of the alarm condition	pulsating Beep for the duration of the alarm condition
door RTE	displays a Green LED until the door is opened or the door unlock time is reached	one long Beep

4.0 Input Connections

4.1 Normally Closed Input Device - Door Status Switch

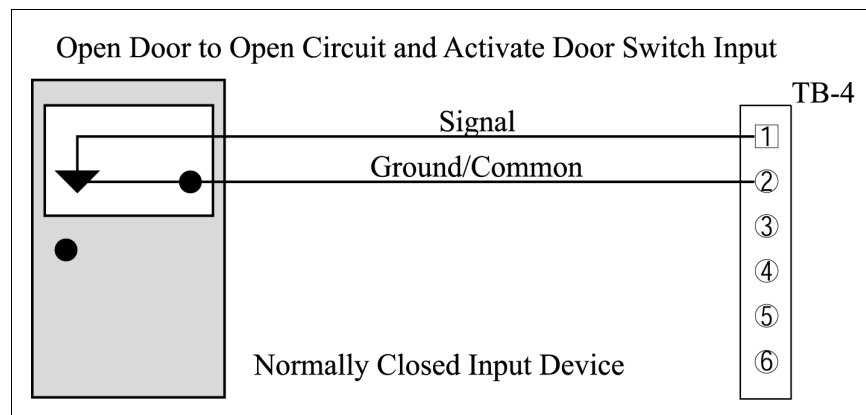

Figure 4: Door Status Switch Input Device

4.2 Normally Open Input Device - Request To Exit (RTE)

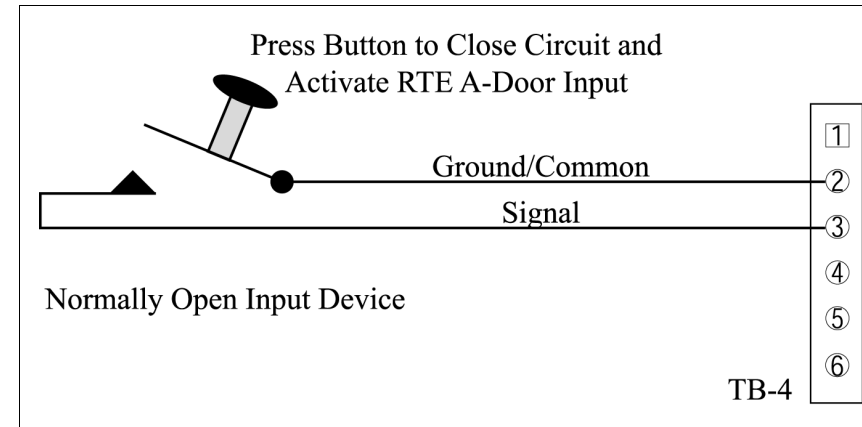

Figure 5: Request To Exit Input Device

4.3 Normally Open Input Device - Auxiliary Request To Exit A-Door

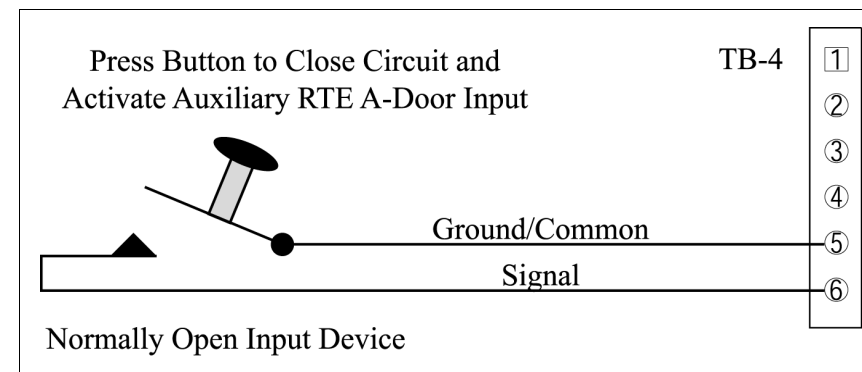

Figure 6: Auxiliary Request To Exit A-Door Input Device

4.4 Normally Open Input Device - Global Unlock

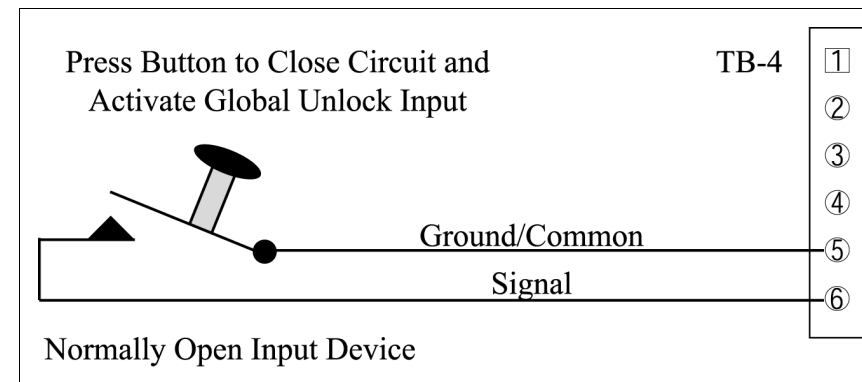

Figure 7: Global Unlock Input Device

5.0 Output Connections

5.1 Lock Relay – Fail-Safe

In the event of a power failure at a door set up with a fail-safe lock relay, the door will automatically unlock allowing people to exit through that door.

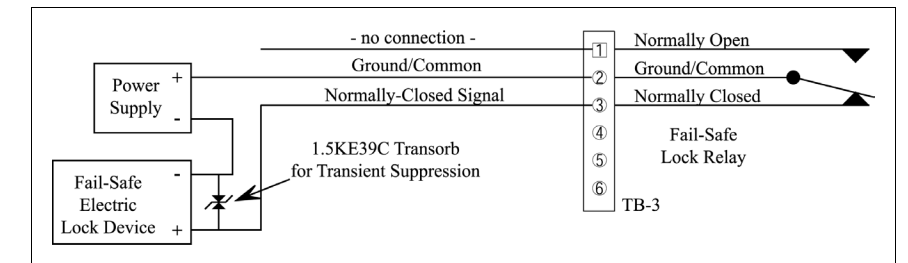

Figure 8: Fail-Safe Lock Relay

5.2 Lock Relay – Fail-Secure

In the event of a power failure at a door set up with a fail-secure lock relay, the door will automatically lock and not allow entrance, but will continue to allow people to exit through that door.

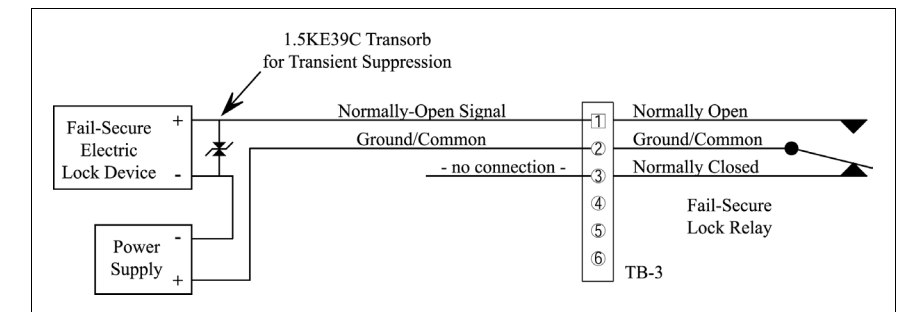

Figure 9: Fail-Secure Lock Relay

5.3 Alarm Out

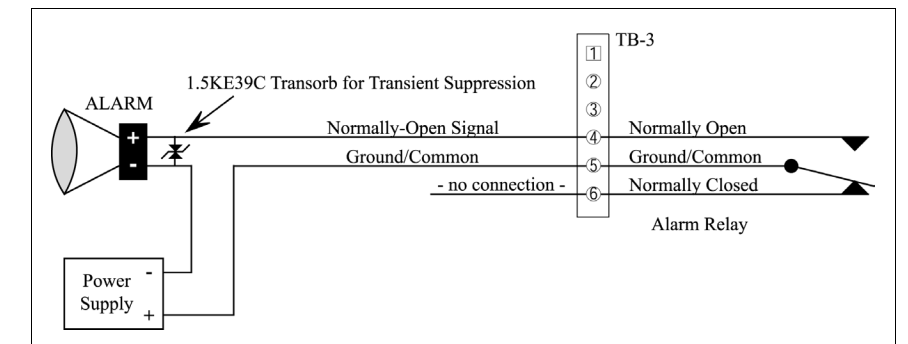

Figure 10: Alarm Out Relay



1530 Old Oakland Road, Suite 100
San Jose, CA 95112 USA
(800) 260-5265 (408) 451-2520 FAX (408) 441-0309
Web: <http://www.kerisys.com> E-mail: sales@kerisys.com