

PXL-250 Tiger Controller

This quick start guide provides, basic installation information, drawings, first time power-on instructions, and short descriptions of key terms and concepts for installing controllers. For comprehensive information regarding the PXL-250 Tiger Controller, please refer to the Technical Reference (P/N 01836-004).

NOTE: It is the responsibility of the installation organization to have only technically qualified personnel performing the installation.

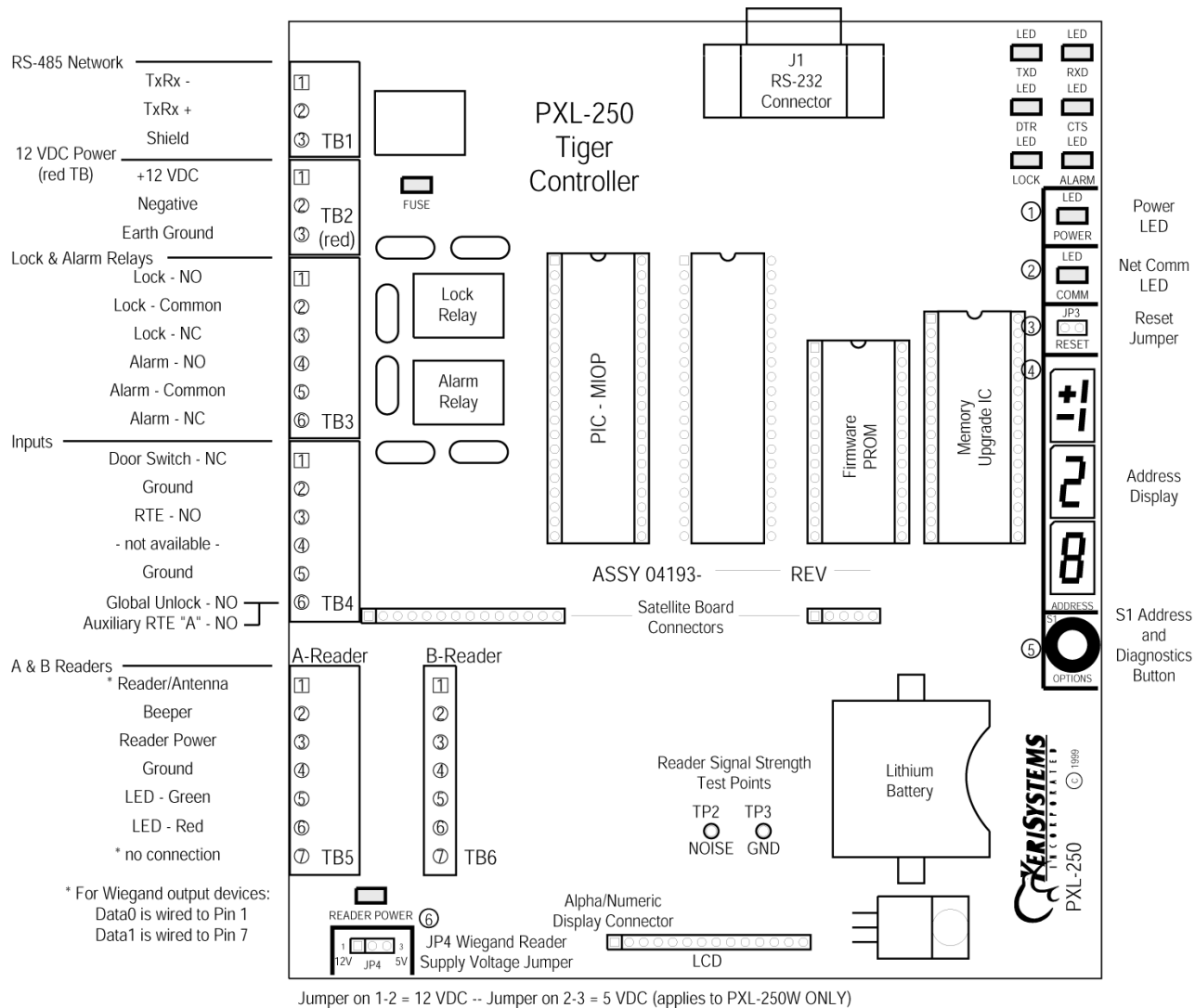

Figure 1: The PXL-250 Controller

PXL-250 Tiger Controller

1.0 Specifications

Unit Dimensions

- PXL-250 controller PCB
 - 6.75 inches high by 6.00 inches wide by 1.75 inches deep, including wiring connectors
 - (17.15 cm by 15.25 cm by 4.45 cm)
- PXL-250 controller PCB with an SB-293 Satellite Board
 - 7.25 inches high by 6.00 inches wide by 1.75 inches deep, including wiring connectors
 - (18.45 cm by 15.25 cm by 4.45 cm)
- PXL-250 controller PCB with an LCD-1 Alpha/Numeric Display
 - 7.70 inches high by 6.00 inches wide by 1.75 inches deep, including wiring connectors
 - (19.60 cm by 15.25 cm by 4.45 cm)
- PXL-250 controller PCB with an SB-293 Satellite Board and an LCD-1 Alpha/Numeric Display
 - 8.10 inches high by 6.00 inches wide by 1.75 inches deep, including wiring connectors
 - (20.60 cm by 15.25 cm by 4.45 cm)
- Enclosure
 - 9.70 inches high by 8.20 inches wide by 2.60 inches deep
 - (24.65 cm by 20.85 cm by 6.60 cm)

Operating Temperature/Humidity Range

- 0°F to 140°F (-18°C to 60°C)
- 0% to 90% Relative Humidity, non-condensing

Controller Power Requirements

- 12 VDC @ 1 A

Current Draw

- maximum current draw 270 mA for a controller plus reader current draw (refer to Table 1 for Reader current draw)
- 120 mA max for a PXL-250 Controller
- 150 mA max for an SB-293 Satellite Board

Table 1: Reader Current Draw

Reader Type					
	MS-3000	MS-4000	MS-5000	MS-7000	MS-9000
Current Draw	50 mA	50 mA	100 mA	200 mA	200 mA

NOTE: If an electronic locking device (such as a magnetic lock, a door strike, or similar device) is to be driven by the same power supply as the PXL-250 controller, please ensure the power supply provides enough current to drive every device connected to that supply plus an adequate safety margin. AC power cannot be used.

Controller Memory Retention

- 5 year lithium battery back up to support controller RAM and real-time clock

Output Relay Contact Rating

- 1 Amp @ 24 VDC



PXL-250 Tiger Controller

Input Device Configuration - 3 Inputs

- Door Sense normally closed
- Request to Exit normally open
- Global Unlock normally open, or Auxiliary RTE A-Door normally open

2.0 Cable Requirements

RS-232 Serial Cable

- four conductor, shielded, stranded, AWG 24 wire (Belden 9534 or a larger gauge)
- 50 feet maximum length (per RS-232 industry specification - greater lengths are not recommended)

RS-485 Network Cable

- two conductor, shielded, twisted pair, stranded, AWG 24 wire (Belden 9501 or a larger gauge)
- 16,000 feet total network length
- refer to the Network Wiring Application Note (P/N 01824-002) for specific network wiring information

Input Power

- two conductor, stranded, AWG 18 wire (Belden 8461 or a larger gauge)
- 200 foot maximum length for systems using an SB-293 with two readers

NOTE: On long power cable runs, the cable resistance causes a drop in voltage at the end of the cable run. Be sure your power supply does provide 12 VDC at the end of the cable run.

Earth Ground

- Single conductor, AWG 18 wire (or a larger gauge)¹

Keri Systems Proximity Readers

- six conductor, shielded, stranded, AWG 24 wire (Belden 9536 or a larger gauge)
- four conductor, shielded, stranded, AWG 24 wire (Belden 9534 or a larger gauge) for the MS-4000 only (there is no beeper or LED in the MS-4000)
- see Table 2 for maximum cable lengths

Table 2: Maximum Cable Lengths by Wire Gauge for Proximity Readers

Reader Type	Cable Length by Wire Gauge		
	100 feet	250 feet	500 feet
MS-3000	AWG 24	AWG 24	AWG 24
MS-4000	AWG 24	AWG 24	AWG 24
MS-5000	AWG 24	AWG 24	AWG 24
MS-7000	AWG 24	AWG 24	AWG 20
MS-9000	AWG 24	AWG 22	AWG 18

1. Ground wire is green with or without yellow tracer.



PXL-250 Tiger Controller

Wiegand Compatible Readers

- five to seven conductor, shielded, stranded, wire – depending upon the Wiegand reader's requirements
- a minimum gauge of AWG 24 is required for data transfer with a 500-foot maximum run length per Wiegand specification¹

Input and Output Connections

- two conductor, stranded, AWG 22 (or a larger gauge)

NOTE: The Lock Output relay may require a heavier gauge of wire depending upon the current demands of the lock and the length of the lock wiring run.

NOTE: If plenum cable is required, please reference the Belden plenum equivalent to the cables listed above.

3.0 When Installing Controllers

DO

- plan ahead to meet power and telephone requirements² for your system (1 phone line for the modem connected to the host computer and one for each master PXL-250 in each network)
- mount controllers in environmentally suitable areas - they require protection from weather and from temperature/humidity extremes
- mount the controller at least 3 feet away from the controller's power supply to prevent EMI radiated from the power supply from affecting the controller
- use the enclosure as a mounting template to mark drilling holes for permanent mounting
- consider mounting requirements - central versus distributed
 - central mounting places all controllers in one location, running lengths of cables out to each door to support readers, inputs and outputs
 - distributed mounting places each controller near the door it supports running short lengths of cable out to each door, but running a long network communication cable
- note the locations of the knockouts in the enclosures and remove the appropriate knockout for the easiest cable routing into the controller
- route all controllers in a network in a single, continuous daisy-chain
- route cables in accessible areas for ease of maintenance
- connect all controllers to a quality earth ground³
- add transient suppression across electric devices attached to a controller output
- use an isolation relay (P/N IRP-1) if attaching to a parking gate, a turnstile, or any application using a large electric motor
- verify the controller's supply voltage is 12 VDC – long power line runs cause a drop in voltage at the end of the run
- verify proper operation of the host computer's COM port
- for a single door application, install the reader to the TB-5, "A" reader connection
- attach the reader to be used for card enrollment to the master controller (this reader can be used for access control as well as enrollment, but during the enrollment process the door associated with the enrollment reader will not allow access until the enrollment process is complete)

1. The wire gauge to use should be determined by the current draw requirements of the Wiegand device and the actual length of the cable run. A +5 VDC and a +12 VDC Wiegand device must have a full +5 VDC or +12 VDC at the device (long cable runs have a voltage drop across the length of the run due to the resistance in the cable). To ensure proper voltage is available at the device a larger gauge of wire (having less resistance) or a power supply at the Wiegand device may be required.
2. Phone lines are only needed for remote communication between host computer and network using a modem.
3. Ground wire is green with or without yellow tracer.



PXL-250 Tiger Controller

DO NOT

- make modem phone line connections through PBX telephone switching systems - most modems are not compatible with PBX systems leading to disconnection problems with the modem
- locate the PXL-250 controller near EMI sources - EMI sources can affect the performance of the controller
- use switching power supplies - they are EMI sources
- route network and reader cables beside power cables - transients on the power cables may be picked-up by network and reader cables
- stretch or over-tension cables
- route over sharp objects
- let the wires get tangled
- mix PXL-250s with PXL-100s in the same network
- route all controllers in a network in spur, hub, or loop configurations
- connect earth ground¹ to the network cable shield - the PXL-250 automatically connects earth ground to the shield at one point on the network to prevent ground loops
- use gender changer plugs when making RS-232 serial communication connections (unless you know it is a "straight-through" plug) - gender changers may have internal wiring changes that can disrupt communications



PXL-250 Tiger Controller

4.0 Wiring Instructions

Refer to Figure 1 on page 1 for all wiring connections.

4.1 Terminal Blocks

Strip away 1/4 inch of insulation and place the wire in the appropriate slot.

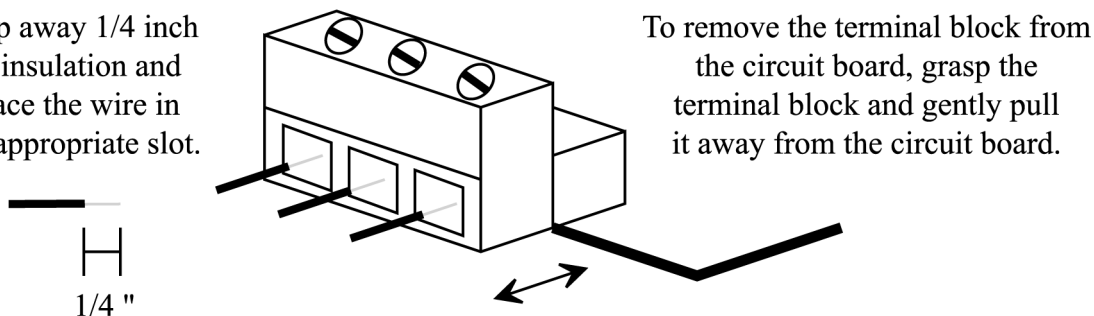

Figure 2: Connecting Wires and Removing Terminal Blocks

NOTE: Screws on terminal blocks must be tightened securely.

4.2 Connecting the Earth Ground and the 12 VDC Power

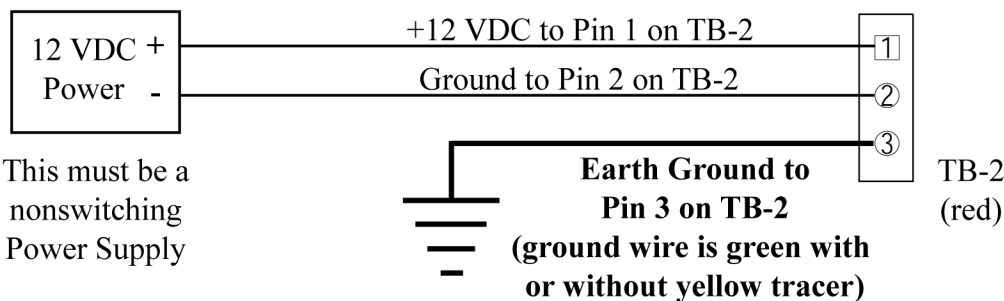

Figure 3: Earth Ground and 12 VDC Power Connections

NOTE: TB2 is colored red to make it easier to tell it apart from the network connector.

PXL-250 Tiger Controller

4.3 Connecting a Keri Systems Proximity Reader to a PXL-250P

- The "A" reader is wired to TB5.
- The "B" reader is wired to TB6.

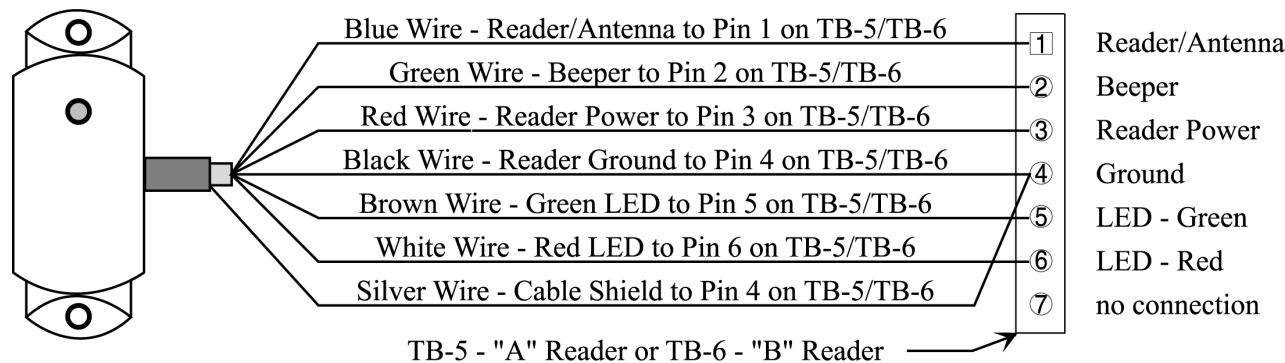

Figure 4: Proximity Reader Connections

4.4 Connecting a Wiegand Compatible Reader to a PXL-250W

The PXL-250W controller can be configured to accept input from single-line LED, dual-line LED, and Essex keypad Wiegand input devices (through the *Doors*TM software).

NOTE: The Wiegand Reader must transfer data according to the Security Industry Association's Wiegand Reader Interface Standard (document number AC-01D-96). Keri Systems, Inc. cannot guarantee the performance or reliability of Wiegand Readers that do not meet these data transfer guidelines.

NOTE: All Keri Systems proximity readers use 12 VDC power while most Wiegand compatible readers use 5 VDC power. Check your reader's power requirements and verify jumper JP4 is set correctly per the Verify the Wiegand Reader Supply Voltage section on page 21. Early revisions of the surface mount PXL-250W mislabeled the JP4 jumper as JP5. All instructions for the JP4 jumper apply to the jumper labeled as JP5 (see Figure 1 on page 1 for the location of the jumper).

NOTE: The wire colors called out in Figures 5 and 6 are industry standard wire colors. However, some manufacturers may not follow these industry standard designations. Before installation, please refer to the Wiegand device's manual to see if the device's wire colors follow the industry standard. If not, then match the wire's purpose to the callouts in Figures 5 and 6 before installation.

PXL-250 Tiger Controller

Make the following connections for a single-line LED or Essex Keypad Wiegand device.

- The "A" input device is wired to TB5.
- The "B" input device is wired to TB6.

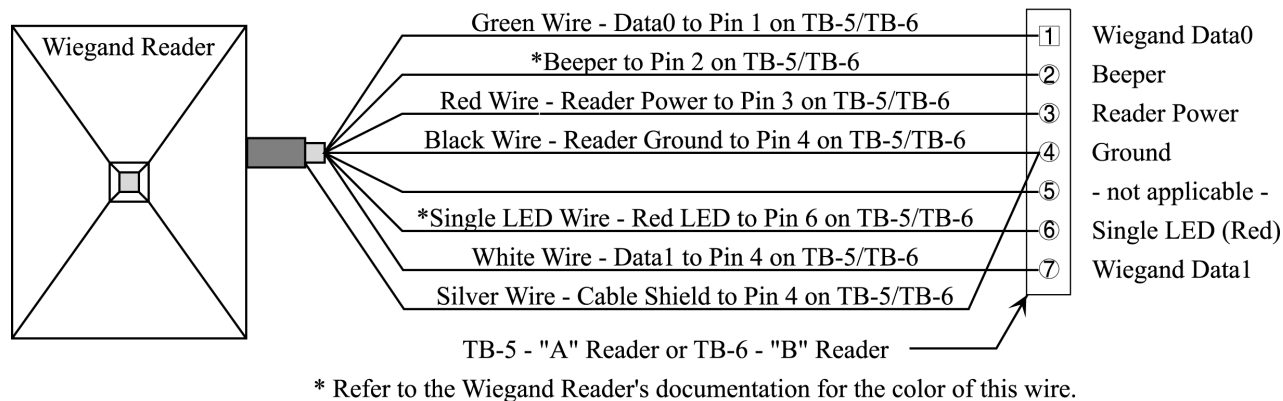

Figure 5: Single-Line LED and Essex Keypad Wiegand Reader Connections

Make the following connections for a dual-line LED Wiegand device.

- The "A" input device is wired to TB5.
- The "B" input device is wired to TB6.

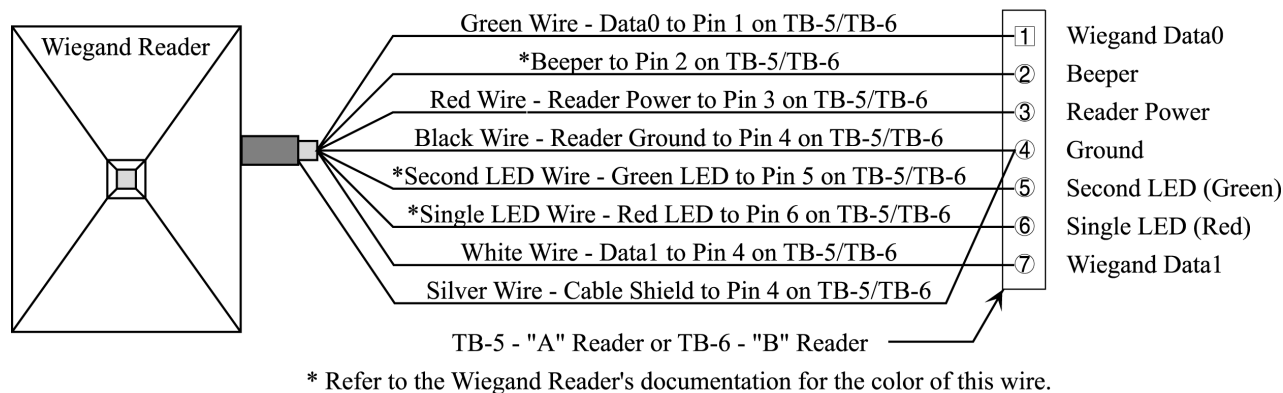

Figure 6: Dual-Line LED Wiegand Reader Connections

PXL-250 Tiger Controller

4.5 Connecting a Door Status Input

Each PXL-250 is shipped with an installation kit including all necessary terminal blocks and transorbs. One of these terminal blocks has a jumper across pins 1 and 2. This terminal block is designated for use on TB-4. If a door switch is not used on the controller, this jumper prevents a continuous door open status alarm from being received by the controller. If a door switch is used, simply remove this jumper and install the door switch leads.

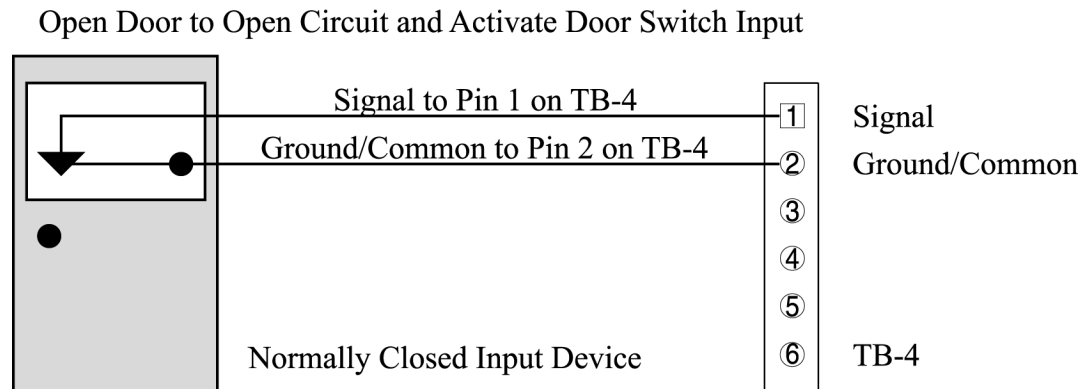

Figure 7: Door Status Input Connections

NOTE: A Door Switch must be installed on any door to which anti-passback is being applied for proper tracking of the anti-passback feature in the Doors program.

4.6 Connecting a Request to Exit (RTE) Input

Press Button to Close Circuit and
Activate RTE A-Door Input

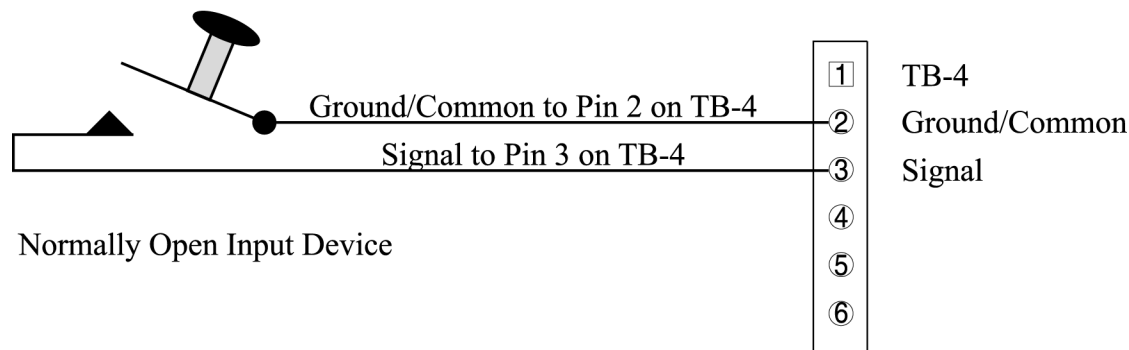

Figure 8: Request to Exit Input Connections

PXL-250 Tiger Controller

4.7 Connecting a General Purpose Input

The general-purpose input is used in conjunction with the programmable input/output feature of the *Doors* access control software. There are three possible uses for the general-purpose input.

- the master controller may be figured for either Global Unlock (see figure 9) or Auxiliary A-door RTE (see figure 10)
- the slave unit may be figured for Auxiliary A-door RTE (see Figure 10)

Make the following connections for a Global Unlock input.

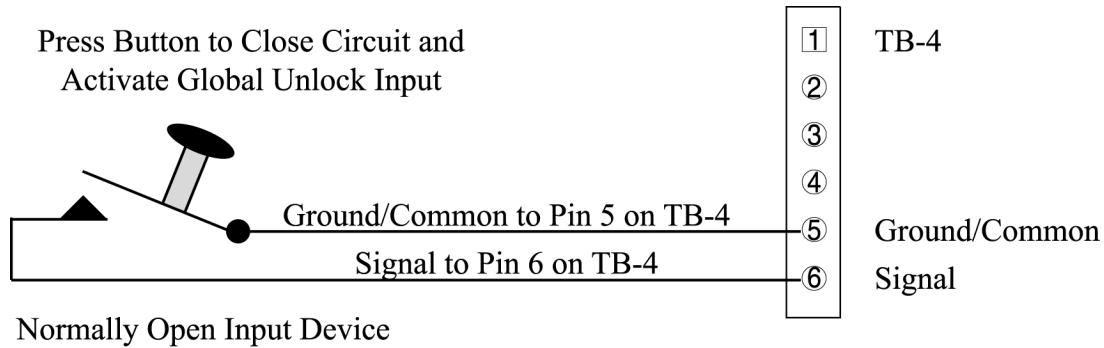

Figure 9: Global Unlock Input Connections

Make the following connections for an Auxiliary A-door RTE input.

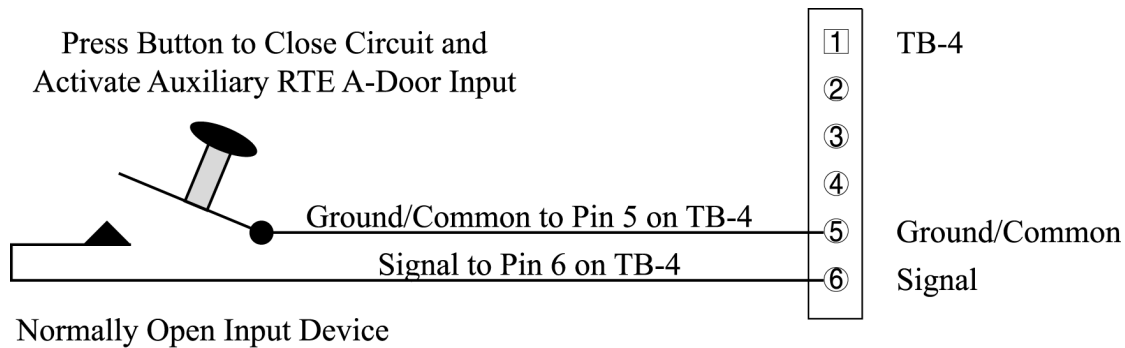

Figure 10: Auxiliary A-Door RTE Input Connections

PXL-250 Tiger Controller

4.8 Connecting an Alarm Output Relay

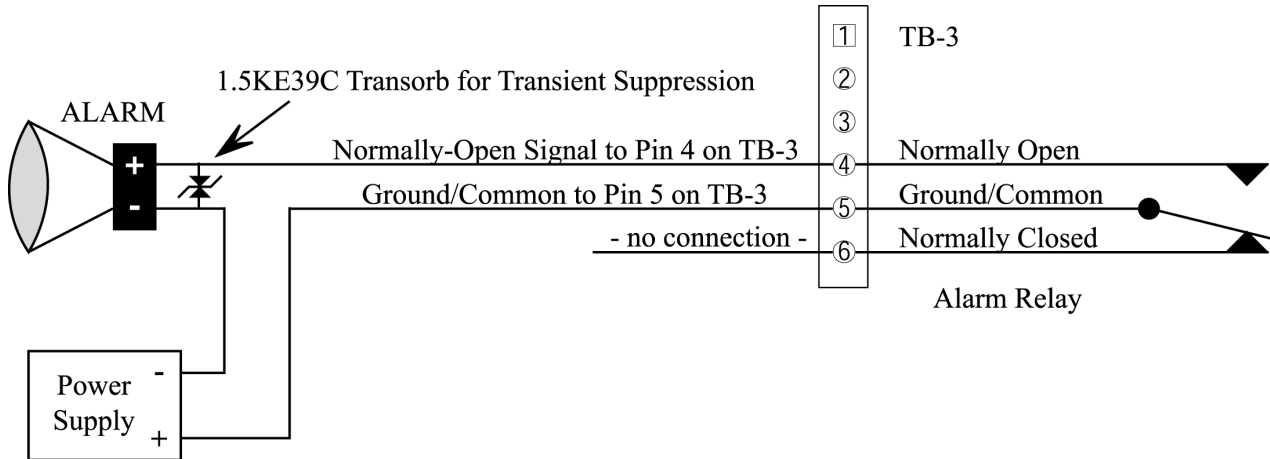

Figure 11: Alarm Output Relay Connections

4.9 Connecting a Fail-Safe Lock Output Relay

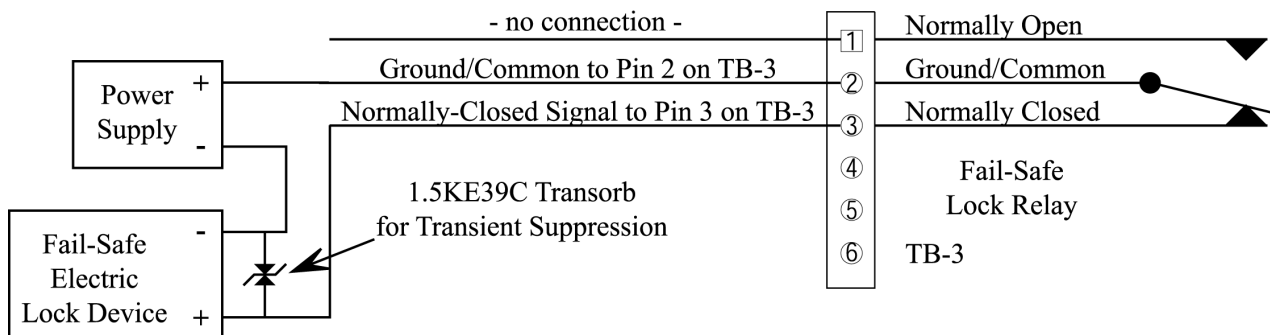

Figure 12: Fail-Safe Lock Output Relay Connections

PXL-250 Tiger Controller

4.10 Connecting a Fail-Secure Lock Output Relay

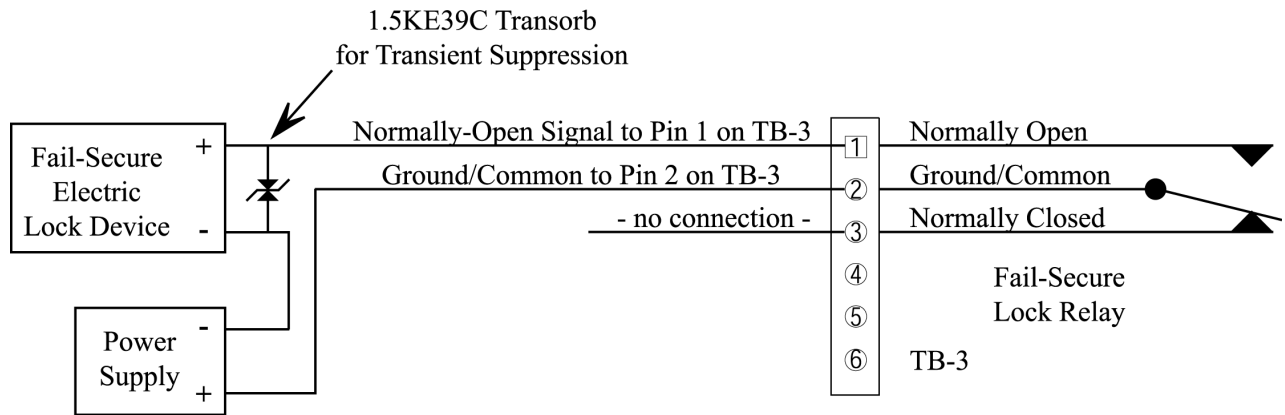

Figure 13: Fail-Secure Lock Output Relay Connections

PXL-250 Tiger Controller

4.11 RS-485 Access Control Network Connection

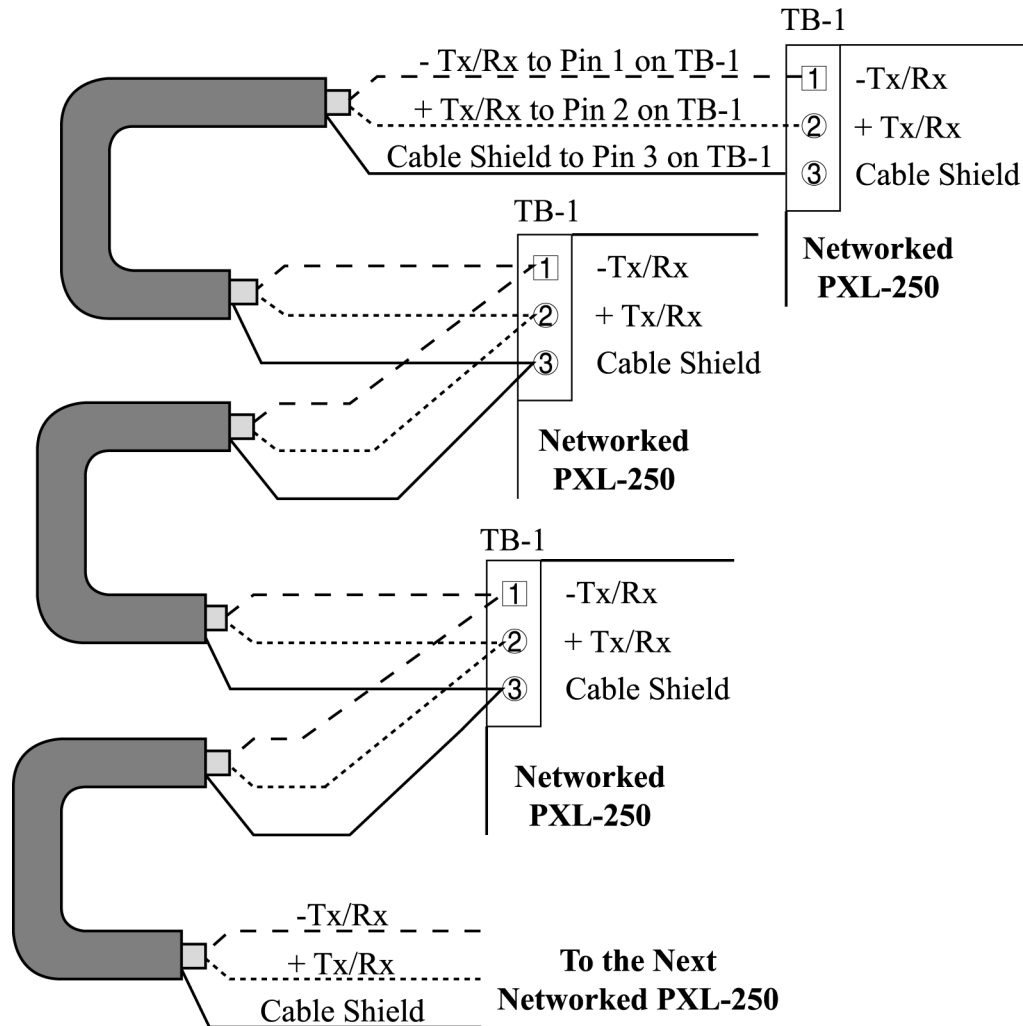

Figure 14: RS-485 Network Connections

PXL-250 Tiger Controller

4.12 Controller RS-232 Serial Port to PC Connection

The controller's RS-232 serial port (see Figure 1 on page 1) provides a communication link between the access control network and the host computer via one of two ways.

- A serial direct connect cable between master controller and host computer (see Section 4.12.1).
- Two modems making a remote connection between the master controller and host computer (see Section 4.12.2 on page 16 and Section 4.12.3 on page 18).

NOTE: Do not use male/female gender changer plugs or 25-pin to 9-pin adapters when making RS-232 serial port connections. These devices may have internal wiring changes that can disrupt communications when implemented in conjunction with the Keri Systems serial wiring instructions. If you must use a gender changer plug, ensure it is a "straight-through" plug.

NOTE: Keri Systems requires using modems from the same manufacturer at both the host computer and the access control network. This eliminates the possibility of incompatibilities between modems from two different manufacturers from affecting the communication between access control network and host computer. Keri Systems cannot be held responsible for problems caused by incompatibilities between modems from two different manufacturers.

NOTE: When using 56K modems to communicate with remote access control networks, all modems must use the same communication format - either X2 or Flex. Incompatibilities between the two formats make some modems of one format incapable of reliable communication with modems of the competing format. Modems using the V.90 specification are compatible regardless of whether they are from an X2 or Flex manufacturer.

4.12.1 Direct Serial Connection – Controller to PC

- If the host computer has a male DB-9 connector on the serial port, you must use a Keri Systems KDP-252 cable or create a cable according to the drawing in Section 4.12.1.1 on page 15.
- If the host computer has a male DB-25 connector on the serial port, you must use a Keri Systems KDP-251 cable or create a cable according to the drawing in Section 4.12.1.2 on page 15.



PXL-250 Tiger Controller

4.12.1.1 PC/DB-9F to PXL-250/DB-9M RS-232 Direct Serial Connection

The Keri Systems part number for this cable is KDP-252.

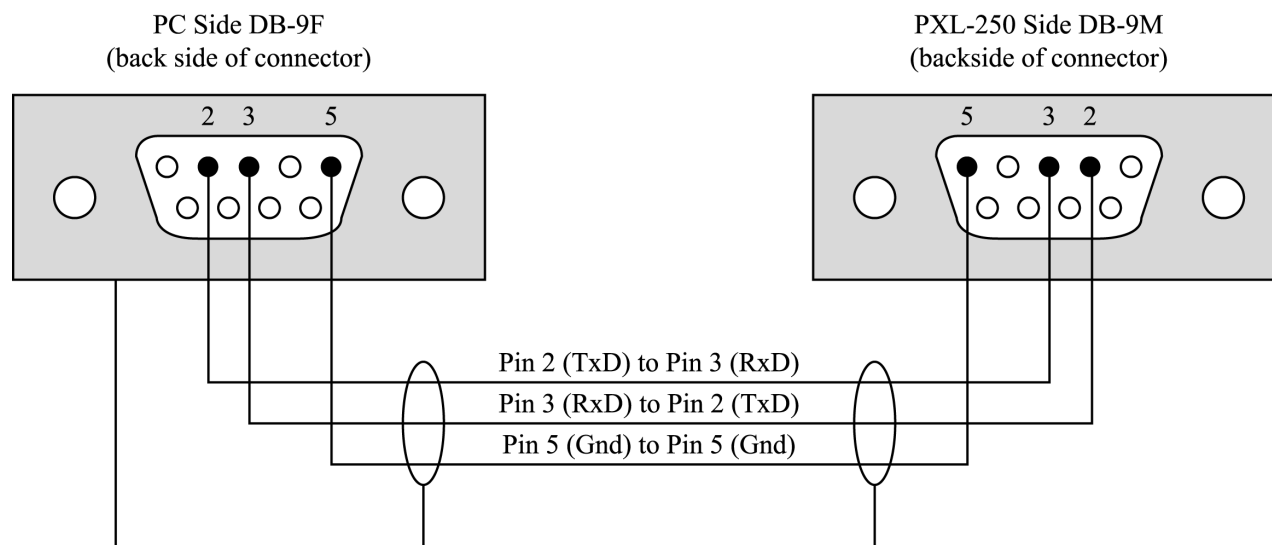

Attach the shield to the connector body at the PC - Do not attach the shield on the PXL side.

Figure 15: PC/DB-9F to PXL-250/DB-9M RS-232 Direct Serial Connections

4.12.1.2 PC/DB-25F to PXL-250/DB-9M RS-232 Direct Serial Connection

The Keri Systems part number for this cable is KDP-251.

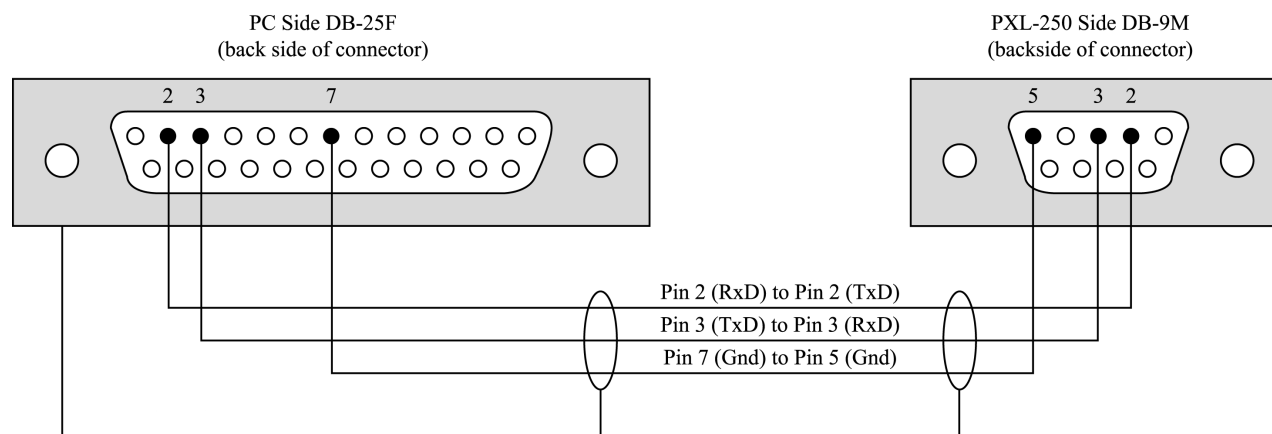

Attach the shield to the connector body at the PC - Do not attach the shield on the PXL side.

Figure 16: PC/DB-25F to PXL-250/DB-9M RS-232 Direct Serial Connections

PXL-250 Tiger Controller

4.12.2 Modem to Controller

To make the connection between access control network and host computer you will use two cables: one between the host computer its modem (see Section 4.12.3 on page 18), and one between the master controller and its modem.

If the modem has a female DB-25 connector, you must use a Keri Systems KDP-336 cable or create a cable according to the drawing in Section 4.12.2.1.

If the modem has a female DB-9 connector, you must create a cable according to the drawing in Section 4.12.2.2 on page 17.

If the modem was purchased from Keri Systems, it come with an adapter that accommodates a female DB-9 connector (should the modem have a DB-9 instead of a DB-25 connector). Use this adapter cable in conjunction with a KDP-336 cable to make the modem/controller connection. See Section 4.12.2.3 on page 18.

4.12.2.1 Modem/DB-25M to PXL-250/DB-9M Serial Port Connection

The Keri Systems part number for this cable is KDP-336.

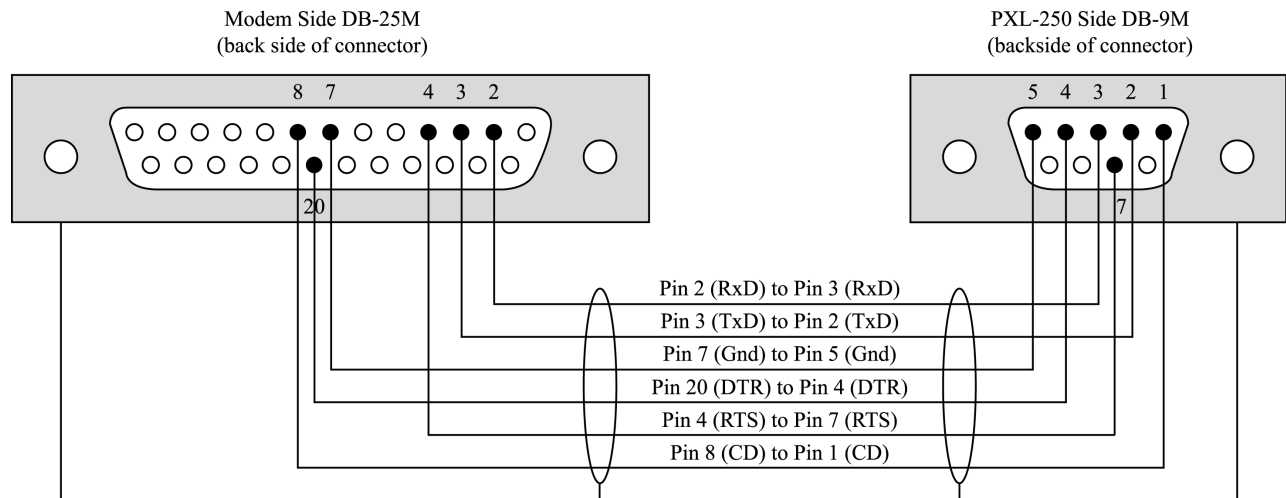

Attach the shield to the connector body at the Modem and the PXL-250.

Figure 17: Modem/DB-25M to PXL-250/DB-9M Serial Port Connections

PXL-250 Tiger Controller

4.12.2.2 Modem/DB-9M to PXL-250/DB-9M Serial Port Connection

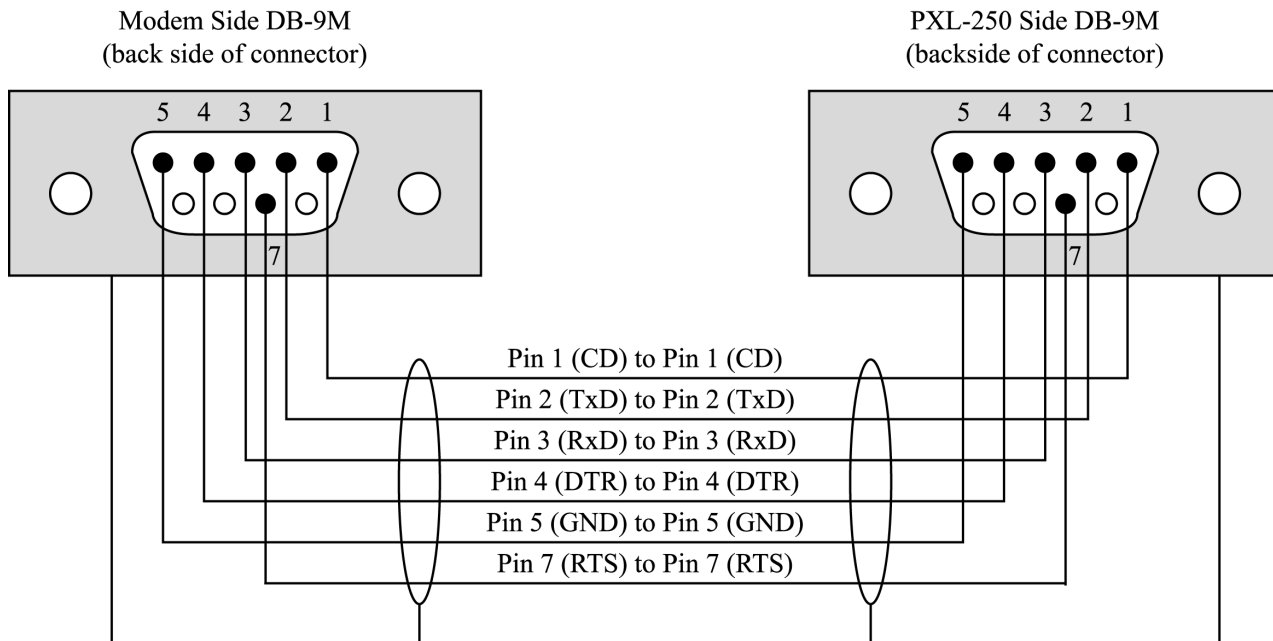

Attach the shield to the connector body at both the Modem and the PXL-250.

Figure 18: Modem/DB-9M to PXL-250/DB-9M Serial Port Connection

PXL-250 Tiger Controller

4.12.2.3 Modem Adapter Cable Connection

This adapter cable is provided, when needed, with a modem purchased from Keri Systems. Connect the adapter cable between the modem and the KDP-336 cable as shown in Figure 19.

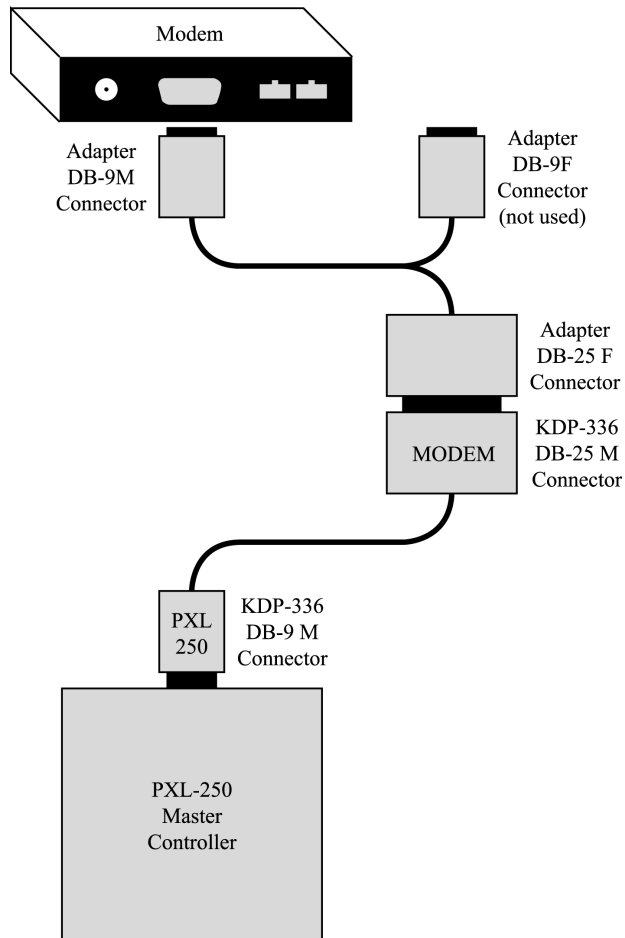

Figure 19: Modem/Adapter Cable/Controller Connection

4.12.3 Modem to PC Serial Connection

Keri Systems does not provide this cable. It is an off-the-shelf item from any computer supplier or electronics store, and its configuration is dependent upon the configuration of the serial port on the host computer. Based on the serial port, there are four possible cables.

- If the modem has a male DB-25 connector and the host computer's serial port has a female DB-9 connector, purchase or create a cable according to the drawing in Section 4.12.3.1 on page 19.
- If the modem has a male DB-25 connector and the host computer's serial port has a female DB-25 connector, purchase or create a cable according to the drawing in Section 4.12.3.2 on page 19.
- If the modem has a male DB-9 connector and the host computer's serial port has a female DB-9 connector, purchase or create a cable according to the drawing in Section 4.12.3.3 on page 20.
- If the modem has a male DB-9 connector and the host computer's serial port has a female DB-25 connector, purchase or create a cable according to the drawing in Section 4.12.3.4 on page 20.

PXL-250 Tiger Controller

4.12.3.1 Modem/DB-25M to PC/DB-9F PC Serial COM Port Connection

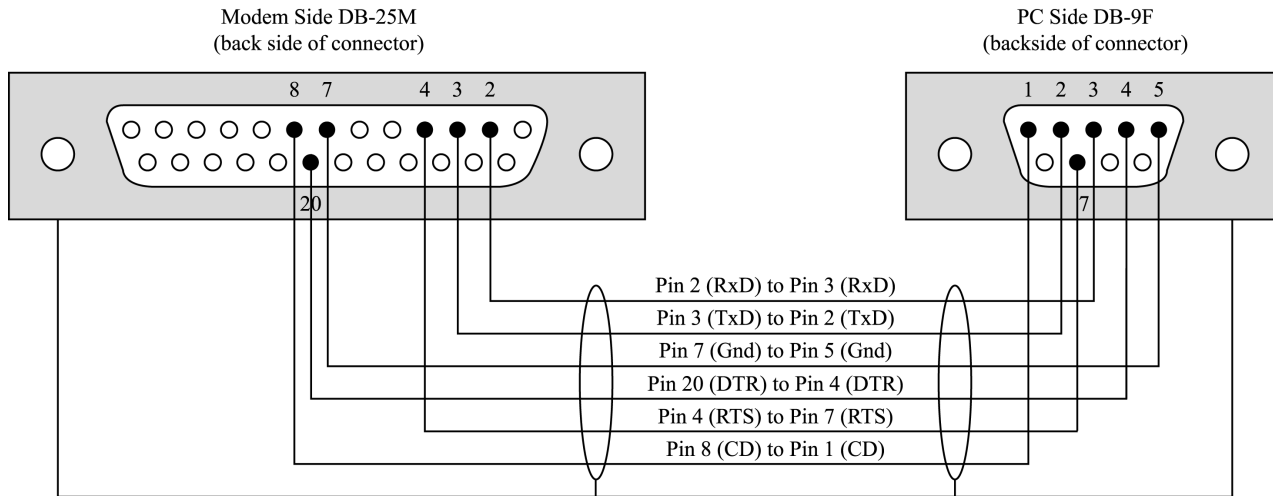

Attach the shield to the connector body at both the PC and the Modem.

Figure 20: Modem/DB-25M to PC/DB-9F PC Serial COM Port Connection

4.12.3.2 Modem/DB-25M to PC/DB-25F PC Serial COM Port Connection

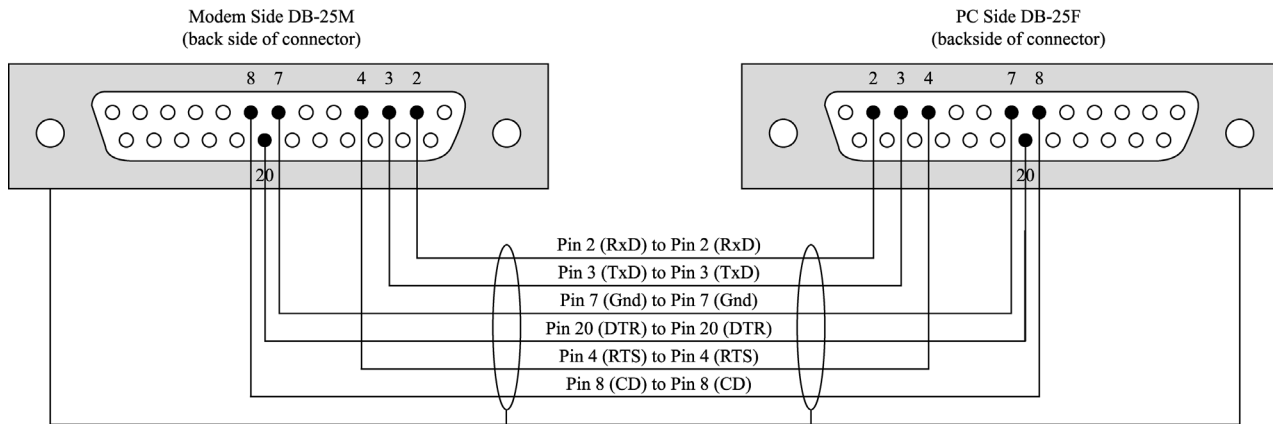

Attach the shield to the connector body at both the Modem and the PC.

Figure 21: Modem/DB-25M to PC/DB-25F PC Serial COM Port Connection

PXL-250 Tiger Controller

4.12.3.3 Modem/DB-9M to PC/DB-9F PC Serial COM Port Connection

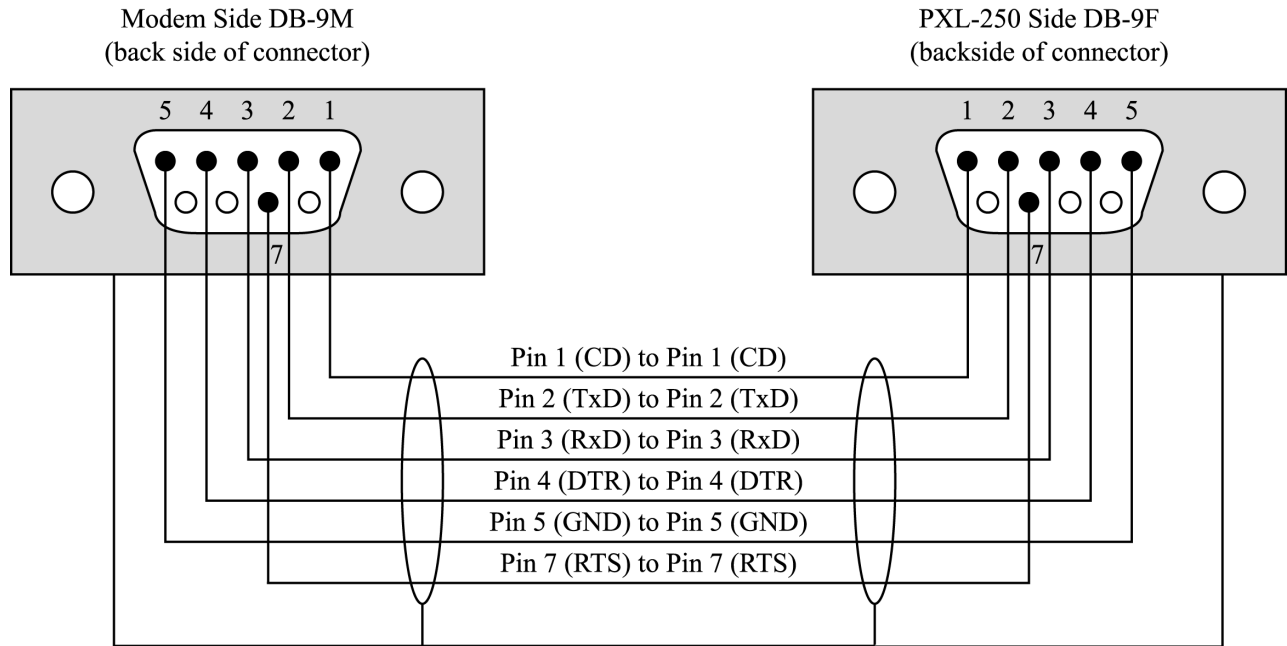

Attach the shield to the connector body at both the PXL-250 and the Modem.

Figure 22: Modem/DB-9M to PC/DB-9F PC Serial COM Port Connection

4.12.3.4 Modem/DB-9M to PC/DB-25F PC Serial COM Port Connection

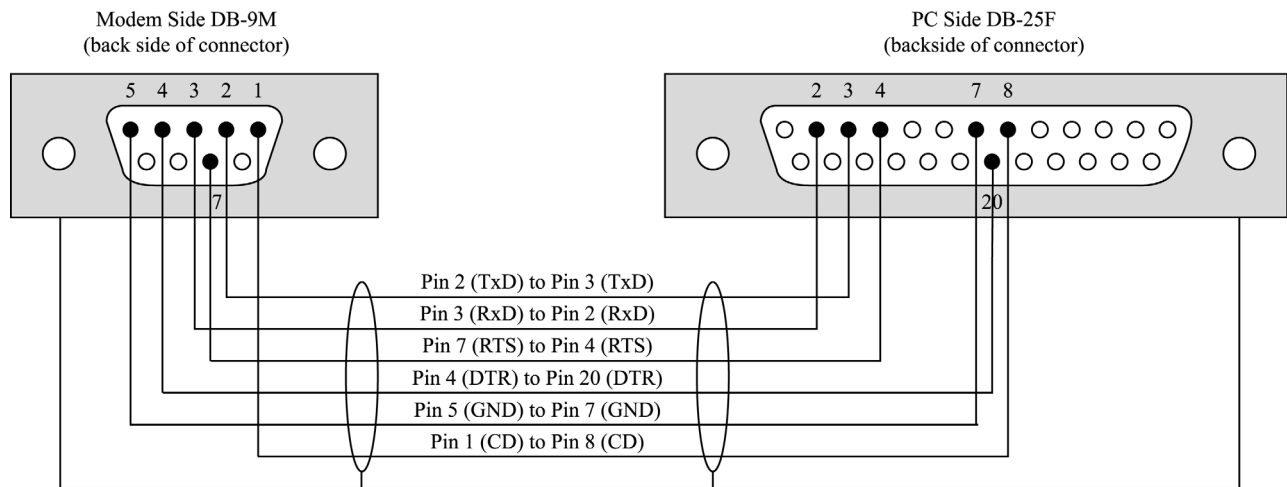

Attach the shield to the connector body at both the PC and the Modem.

Figure 23: Modem/DB-9M to PC/DB-25F PC Serial COM Port Connection

PXL-250 Tiger Controller

5.0 Powering The Controller for the First Time

NOTE: Verify the earth ground¹ has been connected at pin 3 of TB-2 before turning the power on for the first time.

NOTE: Do not connect the 12 VDC power supply's terminal block output to the TB-2 connector on the PXL-250 controller until you have completed all the steps in section 5.1.

5.1 Verify the 12 VDC Supply Voltage

To verify the 12 VDC supply voltage:

1. Set the DVM to a DC volt scale capable of reading 12 VDC.
2. Turn the power supply ON.
3. Place the Red DVM lead on the power supply's terminal block output - Pin 1.
4. Place the Black DVM lead on the power supply's terminal block output - Pin 2.
5. Check the DVM reading. It should read between +12 VDC to +14 VDC.
6. If the DVM does not read between +12 VDC to +14 VDC, verify the power supply is of the correct voltage, verify the cable length does not exceed 200 feet, and verify the cable gauge is AWG 18. This problem must be corrected before power can be supplied to the controller.
7. Turn the power supply OFF.
8. Connect the power supply's terminal block output to the TB-2 connector on the PXL-250 controller.
9. The controller is now ready to be powered ON.

NOTE: On long power cable runs, keep in mind the resistance in the cable itself causes a drop in voltage at the end of the run. The power supply must be able to account for this voltage drop.

5.2 Verify the Wiegand Reader Supply Voltage

NOTE: Early revisions of the surface mount PXL-250W mislabeled the JP4 jumper as JP5. All instructions for the JP4 jumper apply to the jumper labeled as JP5 (see Figure 1 on page 1 for the location of the jumper).

All Keri Systems proximity readers can use from 5 to 12 VDC power (except for the MS-900 which uses 12 to 24 VDC power) while most Wiegand compatible readers use only 5 VDC. For Wiegand configured PXL-250 controllers, there is a warning LED on the mother board to indicate if the controller is applying 12 VDC to the Wiegand compatible reader. If your Wiegand compatible reader does operate on 5 VDC no changes need to be made; the default position for the jumper is set to 5 VDC power. If your Wiegand compatible reader requires 12 VDC, turn the controller power off and move the jumper on JP4 (at the lower left-hand corner of the controller) from pins 2-3 to pins 1-2. When power is restored, the warning LED will turn on indicating 12 VDC is being supplied to the Wiegand compatible reader.

5.3 Resetting the Controller's RAM

If you're turning system power on for the first time, the PXL-250 controller's RAM must be reset before performing any other action. This clears any spurious information that may be in the RAM in preparation for entering your access control information. On the controller, insert a jumper across pins 1 and 2 of JP3. Hold the S1 Address and Diagnostics Button down and turn the controller's power on. The beeper for the reader attached to the controller will beep as power comes on followed by a beep-beep indicating the controller's firmware has reset the controller's RAM. Release S1. If the optional Alpha/Numeric Display has been installed, it will display a "SYSTEM RESET" message. Turn system power off and remove the jumper on JP3. The controller is now ready for use.

1. Ground wire is green with or without yellow tracer.



PXL-250 Tiger Controller

NOTE: Resetting the system RAM completely erases all information within the PXL-250 controller. If there is any information in system RAM from an access control installation and the system RAM is reset, the information in the controller is lost and cannot be recovered.

5.4 Viewing the Controller's Address

To view the controller's address, click S1. The controller's address will appear on the address display for 2 to 3 seconds.

5.5 Setting the Controller's Address

To set the desired operating address for the controller, turn the controller's power off. Verify JP3 is not installed (if JP3 is installed, the controller RAM will be reset when the power is turned on). Hold the S1 Address and Diagnostics Button down and turn the controller's power on. The beeper for the reader attached to the controller will beep as power comes on followed by a beep-beep indicating the controller's firmware has entered the address setting mode. Release S1. The address display LEDs then become active and the controller's address can be set. If an Alpha/Numeric Display is connected to the controller, "ADDRESS CHANGE" will appear on the display. The address range is from 1 to 128 (the Master Controller must be set to address 1).

Quickly double clicking S1 toggles between increasing and decreasing the controller address. The top LED character will display either a "+" or a "-" to show which direction is active. A single click of S1 changes the controller address by 1. If you're at address 128, a +1 click will roll the address over to 1; conversely, if you're at address 1 a -1 click will roll the address over to 128. Holding S1 down rapidly scrolls through the addresses.

After the new address has been set, you must wait approximately 30 seconds. There is a timer in the controller's firmware that assumes that after 30 seconds of inactivity (no address clicks), the entered address is the desired address for that controller. When the 30-second timer expires, there will be a beep-beep indicating the controller has recognized and accepted the new address and the address LEDs will turn off. If an Alpha/Numeric Display is connected to the controller, "UNIT ##" will appear on the display (where ## is the controller's address).

5.6 The Master Controller

The Master Controller must be set to address 1 so that all slave controllers on the access control network can identify the master controller. For the Master Controller to correctly identify all slave controllers on the network, one of two things must be done.

1. The master controller must be the last unit on the network to be powered on. This ensures that when the Master Controller begins polling the network to see what slave units are connected for system configuration, all slave units are already communicating their unique addresses and their configuration information.
2. The Auto-Configuration routine within the *Doors* program must be run. This instructs the Master Controller to poll all controllers on the network for addresses and configuration information (the Auto-Configuration button is found under the Setup/System/Controllers tab).



PXL-250 Tiger Controller

5.7 Reader Responses to Access Control Events

During day-to-day activity, the reader will respond to access control events in a specific manner. Table 3 provides a summary of the reader's LED and beeper actions during access control events.

Table 3: Reader Responses to Access Control Events

Event	Reader's LED Status	Reader's Beeper Status
waiting for an event	displays a steady Amber LED	silent
access granted	displays a Green LED until the door is closed or the door unlock time is reached	one long Beep
access denied	flashes a Red LED	one short Beep
door alarm	flashing Red LED for the duration of the alarm condition	pulsating Beep for the duration of the alarm condition
door RTE	displays a Green LED until the door is opened or the door unlock time is reached	one long Beep

6.0 General Information on Inputs

A controller input detects a state change generated by a device outside the controller that may prompt a response from the controller. Input devices that generate a state change may be normally closed or normally open. This section provides a brief description of normally closed versus normally open inputs.



PXL-250 Tiger Controller

6.1 Normally-Closed

A normally closed input device continually keeps a circuit active or complete. A state change is generated when the normally closed input device is forced open, breaking the circuit. In an access control system, a door switch is a typical example of a normally closed device. While the door remains closed, the switch remains closed. When someone opens the door, the door switch is opened, breaking the circuit and generating a state change. The controller then responds to the state change and generates an output (such as sounding an alarm if the door is a secure door).

6.2 Normally-Open

A normally open input device continually leaves a circuit open, or incomplete. A state change is generated when the normally open input device is forced closed, completing the circuit. In an access control system, a request-to-exit (RTE) button is a typical example of a normally open device. In an access control installation, an RTE button is located on the secure side of a door. While there is no one there pressing the button, the switch remains open. When someone desires to exit through a secure door, they press the RTE button, closing the circuit and generating a state change. The controller then responds to this state change and generates an output (such as unlocking the door to allow egress).

7.0 General Information on Safety versus Security with Door Locks

When installing a door lock there are two things to consider: safety versus security, or should the door be "fail-safe" or "fail-secure."

7.1 Fail-Safe Door Lock

Fail-safe means that if the power should fail at a door (perhaps due to a power outage or equipment failure), the door will automatically unlock allowing entrance or egress. Power is required to keep the door locked. A fail-safe door ensures people will be able to enter and exit a secured area through that door in the case of an emergency. A typical fail-safe application may use a magnetic lock. In this application, the controller energizes the lock relay, causing the lock relay to change its state. In its new state the normally closed circuit is opened breaking the power to the magnetic lock and allowing the door to be opened.

7.2 Fail-Secure Door Lock

Fail-secure means that if the power should fail at a door (perhaps due to a power outage or equipment failure), the door will automatically lock and not allow entrance but will continue to allow egress. Power is required to unlock the door. A fail-secure door ensures a secured area remains secure regardless of the situation. A typical fail-secure application may use a door strike. In this application, the controller energizes the lock relay, causing the lock relay to change its state. In its new state the normally open circuit is closed activating the release mechanism for the door strike on the door to be opened.

PXL-250 Tiger Controller

Quick Start Guide

PXL-250

This page is intentionally left blank.



1530 Old Oakland Road, Suite 100
San Jose, CA 95112 USA
(800) 260-5265 (408) 451-2520 FAX (408) 441-0309
Web: <http://www.kerisys.com> E-mail: sales@kerisys.com

01835-002 Rev. 4.2

Page 25 of 25