

Network Wiring

Keri Systems RS-485 multi-drop network requirements are very simple and forgiving. It is a half-duplex, RS-485 communication bus. This is a very robust system and has been tested to exceed standard RS-485 network specifications. Using approved cable and good installation practices, the network will operate satisfactorily with up to 16,000 feet of cable for systems of up to 128 PXL-500/PXL-510 controllers, each with an SB-593.

- The network configuration can be a single-run multi-drop, a star, multiple stars, T-taps, etc.
- The master controller can be located at any point in the network.
- Take care and ensure the Tx- and Tx+ lines are not cross-wired.
- Shield integrity must be maintained throughout the network installation.
- If there are more wires than will reliably fit into the PXL-500/PXL-510 terminal block, Keri recommends using an external terminal strip to combine the cables and then connect a single wire to the terminal block.
- The recommended cable is Belden 9501 or its equivalent. This is a single-pair, twisted, shielded, AWG 24 cable.

1.0 Earth Ground Requirements

A quality earth ground connection to the master controller is required to ensure the best possible operating conditions. Without a quality earth ground connection, the access control network will be susceptible to voltage surges induced by outside sources and other forms of interference.

1. An earth ground helps protect the network from unwanted power surges.
2. An earth ground helps provide a means of reducing other unwanted interfering signals, further stabilizing system operation.
3. The shield on the RS-485 cable is **not** to be connected to earth ground at any point. The shield is automatically grounded via circuitry on the PXL-500/PXL-510 controller.



Network Wiring

2.0 Multi-Drop Network Guidelines

The following guidelines apply when installing a multi-drop network.

1. A multi-drop network can use a "star" pattern. Keri Systems defines a star pattern as sets of multi-drop controller lines all connected to the master controller.
2. Any number of multi-drop lines can be installed as long as the total cable length of all multi-drop lines (all cabling in the network) is no more than 16,000 feet.
3. Any number of controllers can be installed in any multi-drop line (up to the 128-controller limit for the entire network).

2.1 The Master Controller

If an existing network is being upgraded to an extended network or when installing a new extended network, the master controller printed circuit board must be at level 04196-001 Rev. L or greater to ensure proper network termination. The printed circuit board level information is near the center of the board (see Figure 1).

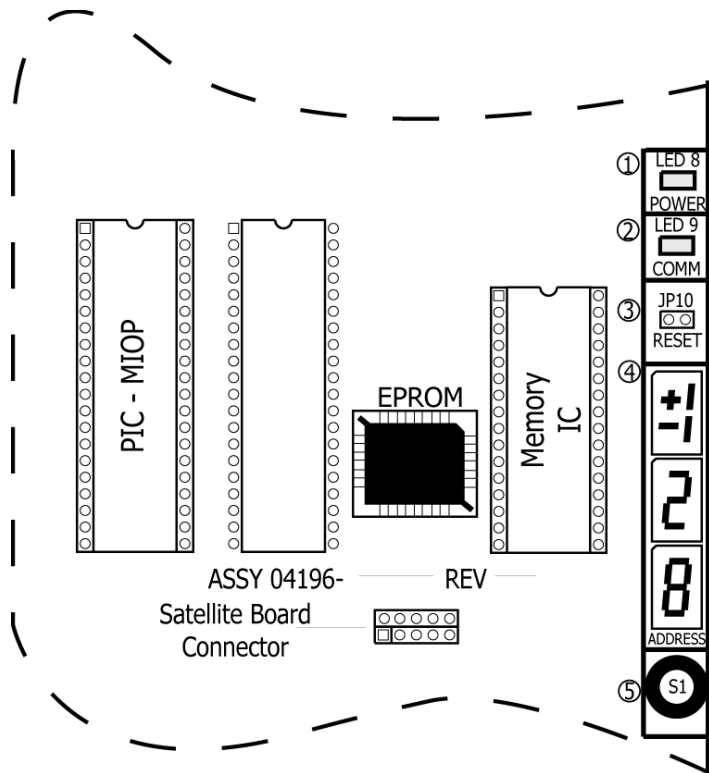

Figure 1: Location of Printed Circuit Board Level

Network Wiring

2.2 Generic Multi-Drop Network Wiring Diagram

Figure 2 provides a generic drawing of a possible multi-drop network, according to the guidelines in Section "2.0" on page 2.

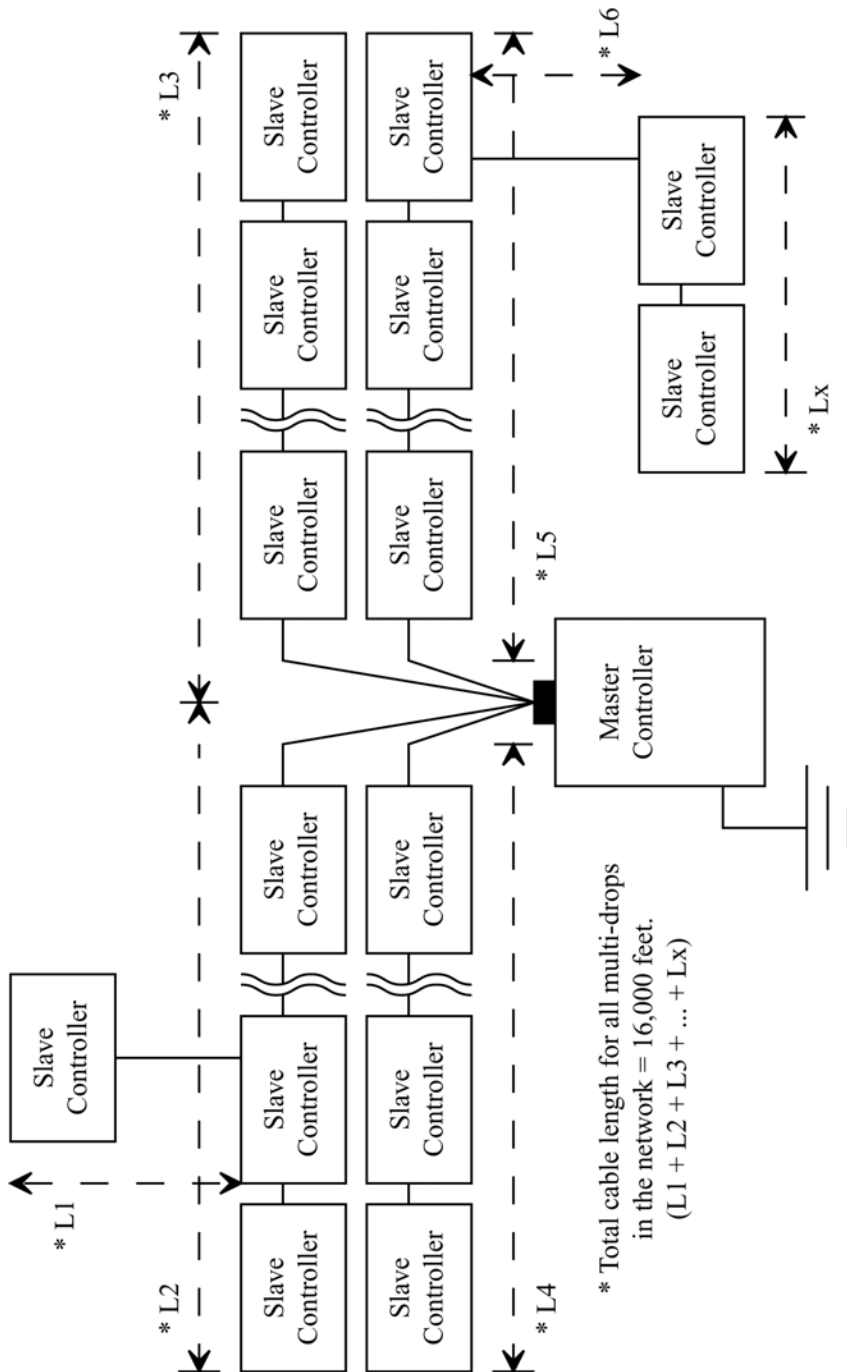

Figure 2: Generic Multi-Drop Network Diagram



Network Wiring

Application Note

PXL-500 / PXL-510

This page is intentionally left blank.



2305 Bering Drive
San Jose, CA 95131 USA
(800) 260-5265 (408) 435-8400 FAX (408) 577-1792
Web: www.kerisys.com E-mail: sales@kerisys.com

01946-001 Rev. C