

# SB-293 Quick Reference

This Quick Reference is designed for the experienced installer as a quick reference while installing to ensure all connections are made and working properly.

The Quick Reference is designed as a checklist of sorts where you may check off as each installation procedure is completed. Additional information is given for those who need to be reminded of what is performed during that part of the installation. For detailed information on installing the SB-293 Satellite Board, see the SB-293 Satellite Board Quick Start Guide (P/N 01837-003) or the PXL-250/SB-293 Technical Reference Manual (P/N 01836-004).

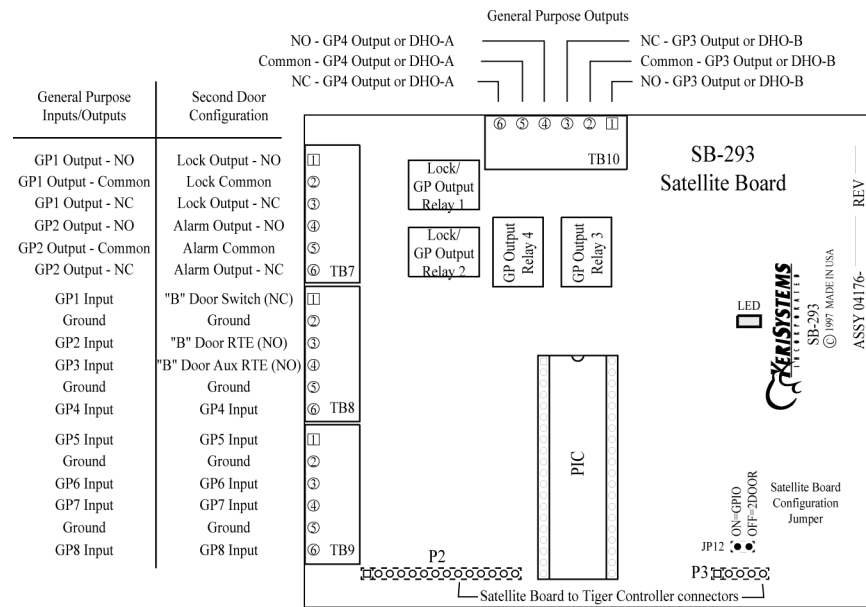

Figure 1: SB-293 Board

## 1.0 Before Turning Power ON

- Install the SB-293 Satellite board on a PXL-250 controller.
  1. Turn the controller's power OFF.
  2. Line up the upper left-hand corner of the Satellite PCB with the controller PCB.
  3. Line up the stand-offs in the top two corners of the Satellite PCB with corresponding mounting holes in the controller PCB (see the Satellite/Controller Installation drawing below).
  4. Align the motherboard connector pins (J2 and J3) to the Satellite Board connectors (P2 and P3).
  5. Gently press the two boards together with each stand-off into its mounting hole and with the connector pins meshing together. Once power has been applied, the LED on the SB-293 (see Figure 1) will turn green if the J2 to P2 connector pins have been meshed together properly.
- If the controller is not using a door contact switch, verify a door switch input jumper is connected between TB-8, pins 1 and 2.
- Verify JP-12, the 2-Door/Input-Output configuration jumper is set correctly: OFF for 2-Door control – ON for general purpose I/O
  - Jumper across JP12, pins 1 and 2, configures the Satellite board for general purpose inputs and outputs.
  - NO jumper across JP12 configures the Satellite board for second door control with additional inputs and outputs. When the Satellite board is configured for second door control, the primary door must be connected to the "A" reader (TB-5 on the PXL-250 controller board) and the secondary door must be connected to the "B" reader (TB-6 on the PXL-250 controller board).

## 2.0 Input Connections

### 2.1 Normally Closed Input Device – Door Status Switch

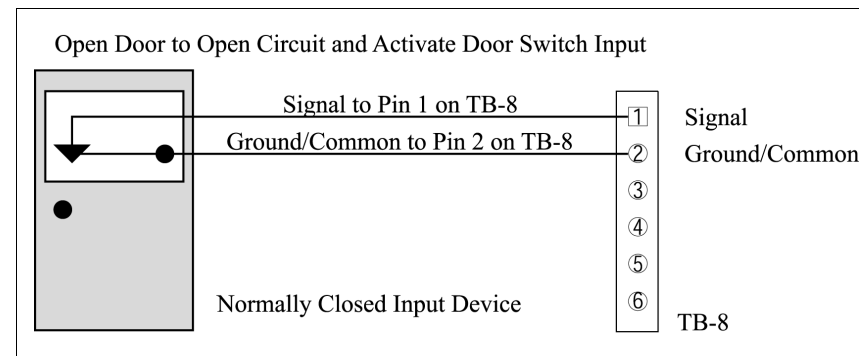

Figure 2: Door Status Switch Input Device

### 2.2 Normally Open Input Device – Request To Exit (RTE)

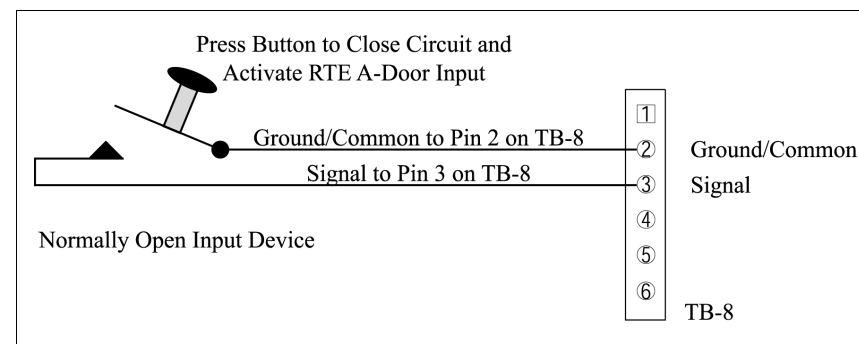

Figure 3: Request To Exit Input Device

### 2.3 Normally Open Input Device – Auxiliary Request To Exit B-Door Input

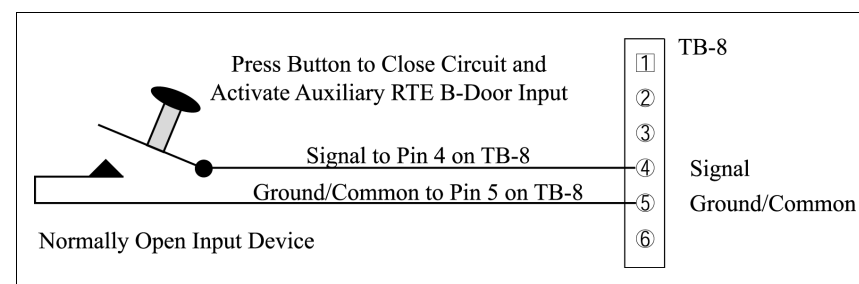

Figure 4: Auxiliary RTE B-Door Input Device

## 2.4 General Purpose Input Device

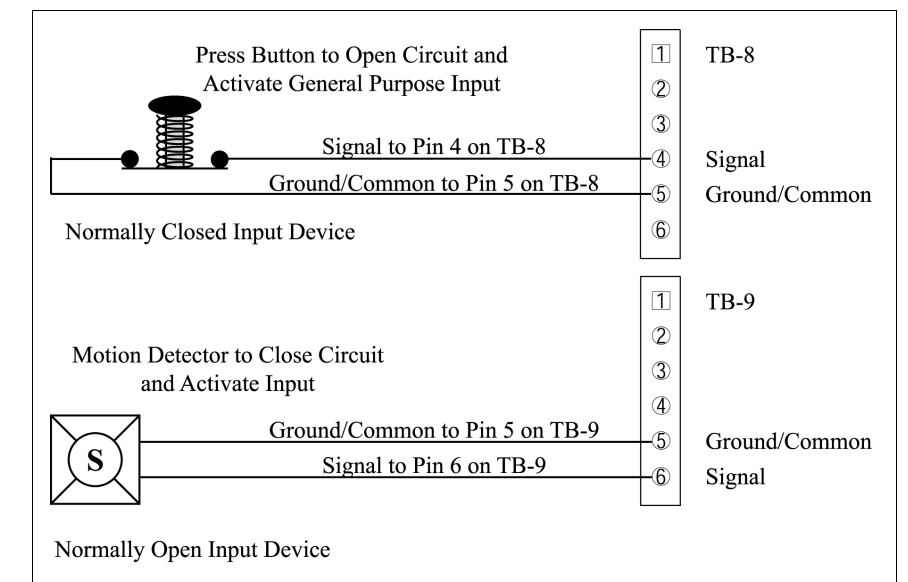

Figure 5: General Purpose Input Device

## 3.0 Output Connections

### 3.1 Lock Relay – Fail-Safe

In the event of a power failure at a door set up with a fail-safe lock relay, the door will automatically unlock allowing people to exit through that door.

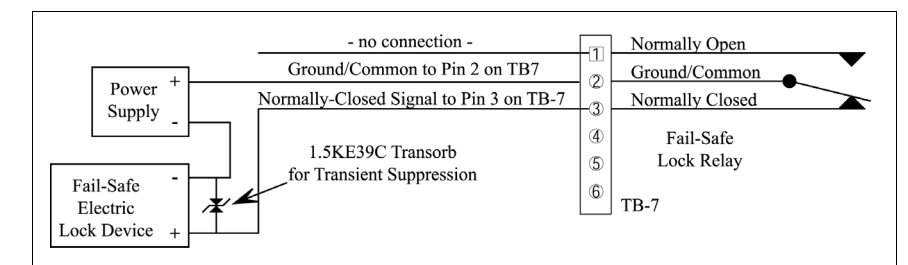

Figure 6: Fail-Safe Lock Relay

### 3.2 Lock Relay – Fail-Secure

In the event of a power failure at a door set up with a fail-secure lock relay, the door will automatically lock and not allow entrance, but will continue to allow people to exit through that door.

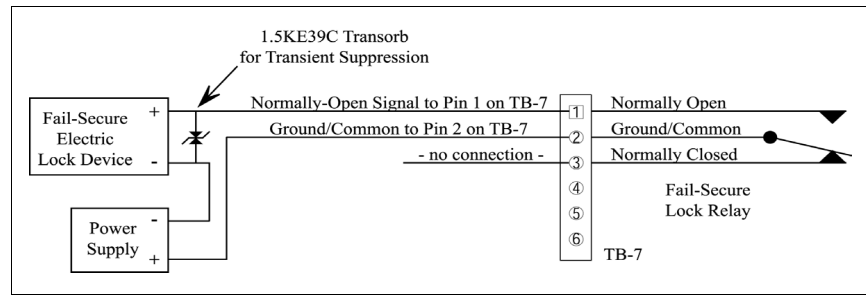

Figure 7: Fail-Secure Lock Relay

### 3.3 Alarm Out

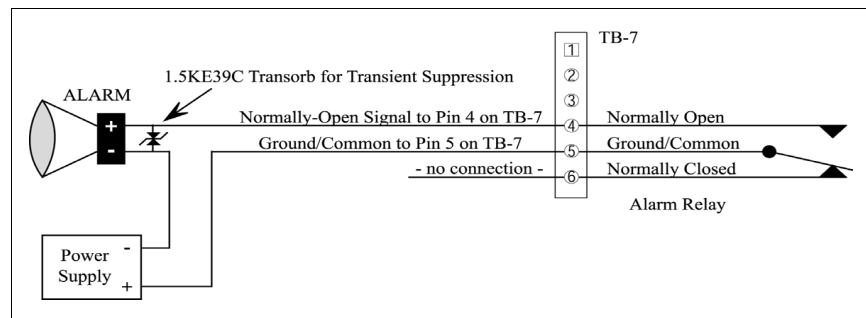

Figure 8: Alarm Out Relay

### 3.4 Door-A Held Open Alarm Relay

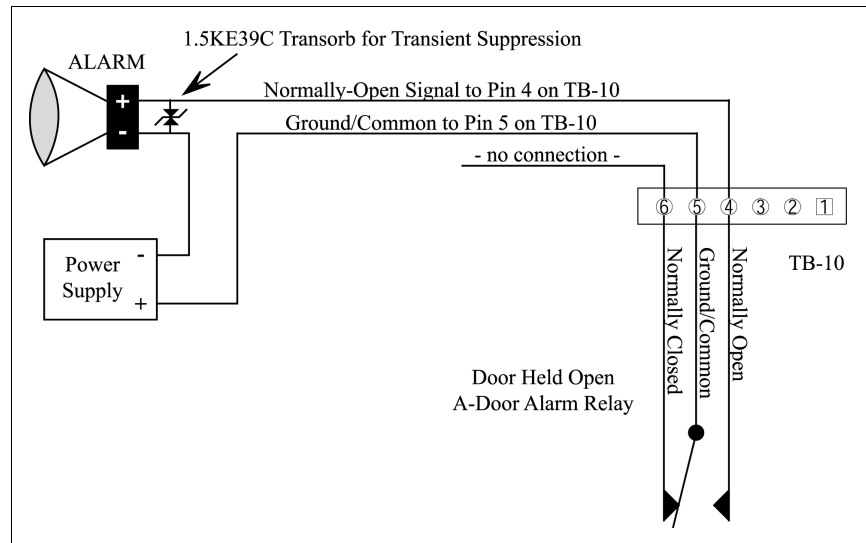

Figure 9: Door-A Held Open Alarm Relay

### 3.5 Door-B Held Open Alarm Relay

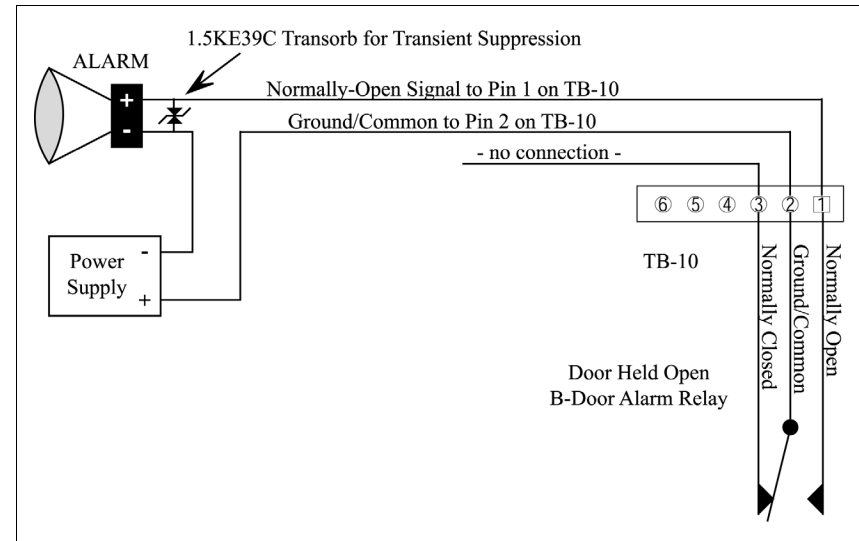

Figure 10: Door-B Held Open Alarm Relay

## 4.0 General Purpose Relay Connections

### 4.1 Normally Closed General Purpose Relay

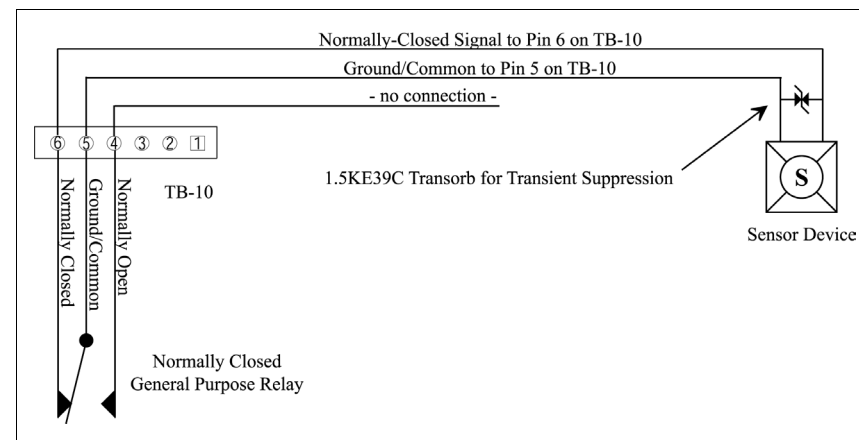

Figure 11: Normally Closed General Purpose

### 4.2 Normally Open General Purpose Relay

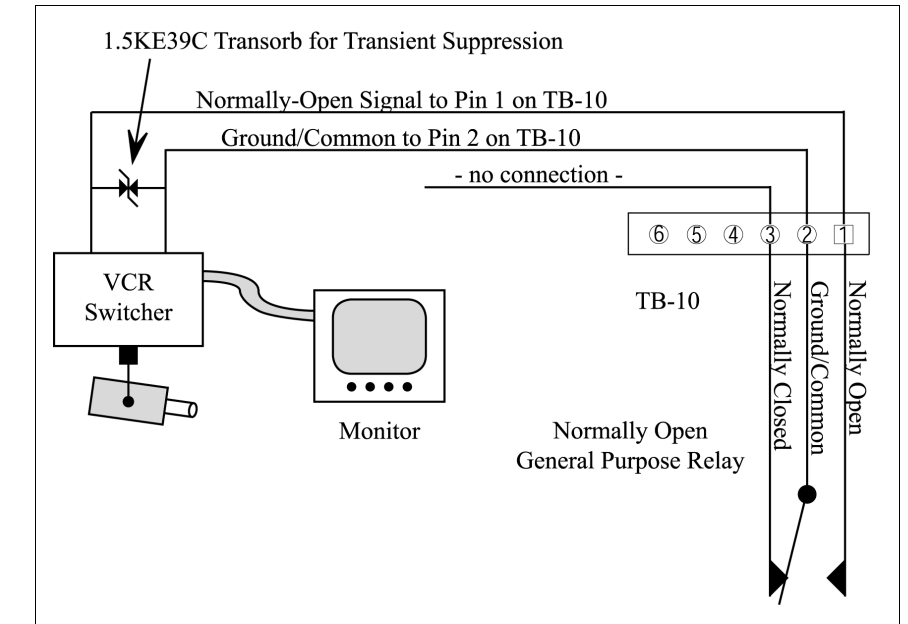

Figure 12: Normally Open General Purpose Relay



1530 Old Oakland Road, Suite 100  
 San Jose, CA 95112 USA  
 (800) 260-5265 (408) 451-2520 FAX (408) 441-0309  
 Web: <http://www.kerisys.com> E-mail: [sales@kerisys.com](mailto:sales@kerisys.com)