

# Surge and Lightning Protection

Lightning is an act of nature and cannot be predicted or controlled. There is NOTHING that will COMPLETELY protect electronic equipment from the massive effects of a direct or near hit from lightning. Keri Systems has taken a number of steps to protect the electronic components and pathways of its equipment from voltage surges that may enter them. The pathways: DC power, RS-232 communications, RS-485 communications, reader wiring, input wiring, and lock and relay control all have been protected using a variety of devices, including MOVs, diodes, transorbs, and ground pathways.

Although these on-board or internal devices are not able to protect controllers from the excessive voltage surges generated by lightning, external devices are available that provide additional protection. When a controller is installed in an environment that regularly experiences high voltage surges, such as those caused by lightning, an external Surge Protection Device (SPD) may offer the additional protection needed for reliable operation.

An SPD diverts excess energy away from the device being protected to a quality earth ground connection. For maximum protection, the connection to the earth ground should be as short as possible, preferably less than three feet using 18 gauge, or greater, wire. If the connection must be longer than three feet, a braided cable intended for grounding purposes must be used.

An SPD needs to be used on the RS-485 communications line when the RS-485 wiring leaves and enters a building or outside location. Normally, an SPD is not needed on the RS-485 wiring within a building or outside location (see Figure 1 and Figure 2 on page 2).

## 1.0 HyperLink Surge Protection Device

Keri Systems recommends the use of the HyperLink Surge Protection Device model HGLN-D2-05 ([www.hyperlinktech.com](http://www.hyperlinktech.com)) to help protect against electrical surges.

The HyperLink SPD is designed for 2 wire or 4 wire RS-485 communication. The unit is placed in series with the RS-485 data lines.

The HyperLink SPD is a high performance three stage lightning protector offering greater protection than a single stage lightning protector. Stage one is comprised of a differential gas discharge tube. Stage two is a pair of current limiting series resistors. Stage three is a high speed, low capacitance diode array.



# Surge and Lightning Protection

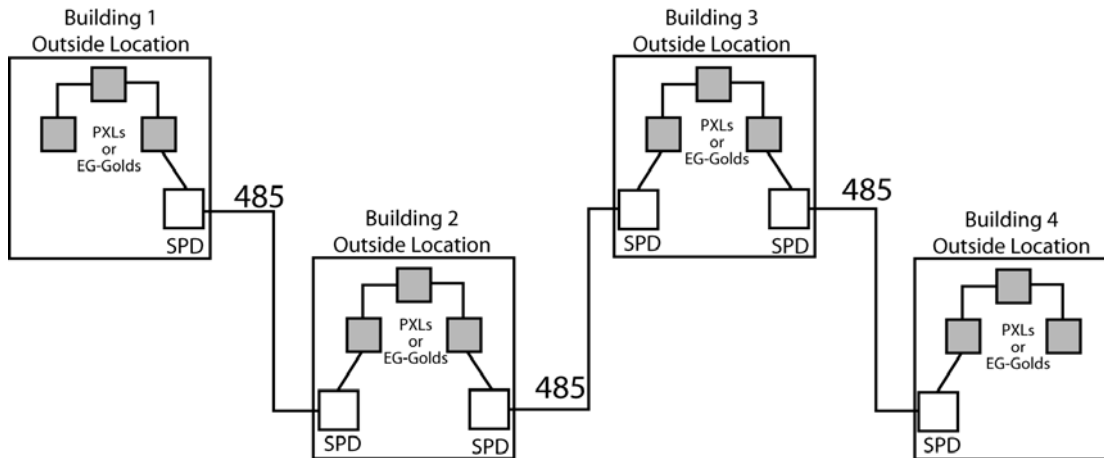

**Figure 1: Typical Installation**

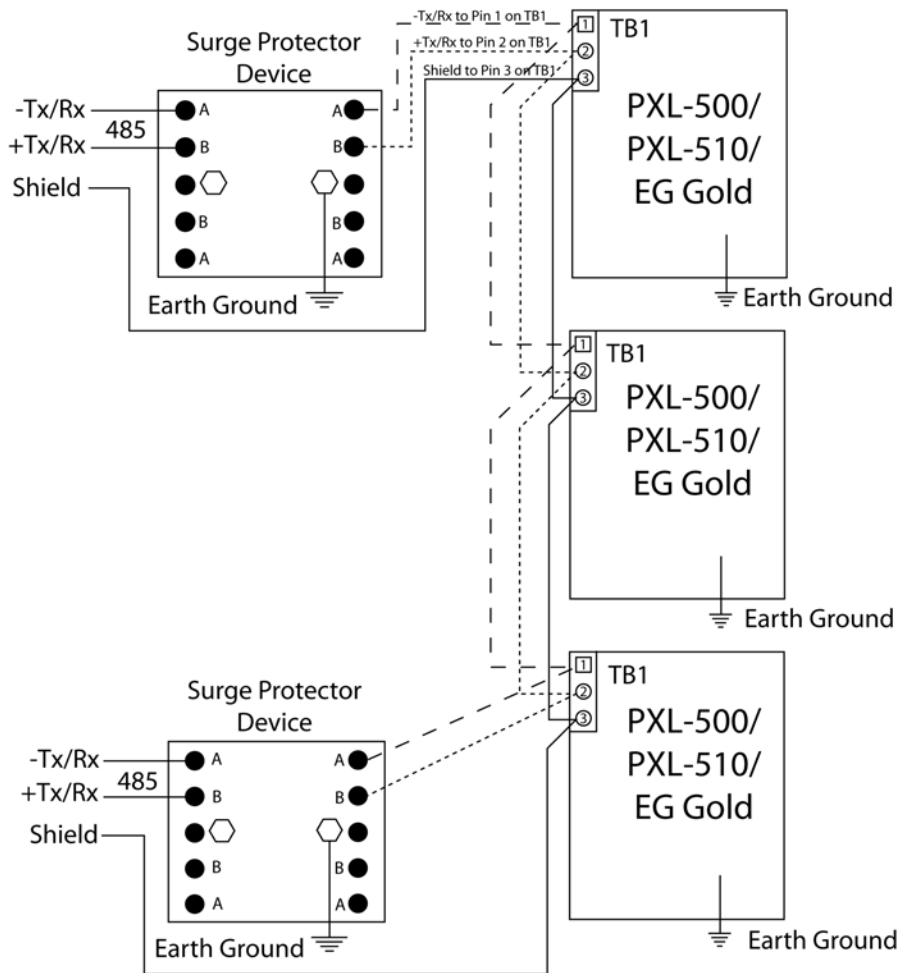

**Figure 2: Building or Outside Location Network**