

Wireless 485 Network Transceiver

Keri's KWX Wireless Transceivers allow you to easily create a wireless communication network between PXL controllers in an RS-485 network. Just as in wired controller networks, the KWX works on systems as simple as two or three doors, all the way up to 256 door systems, and in distances of up to a mile between controllers when using long-range antennas.

KWX Wireless Transceivers operate in a frequency hopping mode in the 915 MHz ISM band. Standard units have a nominal range of 300 feet. Three antenna options are available, extending the range of the wireless units.

Controller networks can use a combination of KWX units and RS-485 2-conductor, shielded, twisted-pair cabling, allowing you to mix and match wired and wireless connections to create the fastest and most economical Keri Access Control installation. The KWX connection to the controller uses the same type of cabling as in standard wired connections.

Keri's KWX Wireless Transceivers are compatible with PXL-500/510, PXL-250, and Entraguard controllers, allowing these transceivers to be added to existing networks as well as be used in new installations.

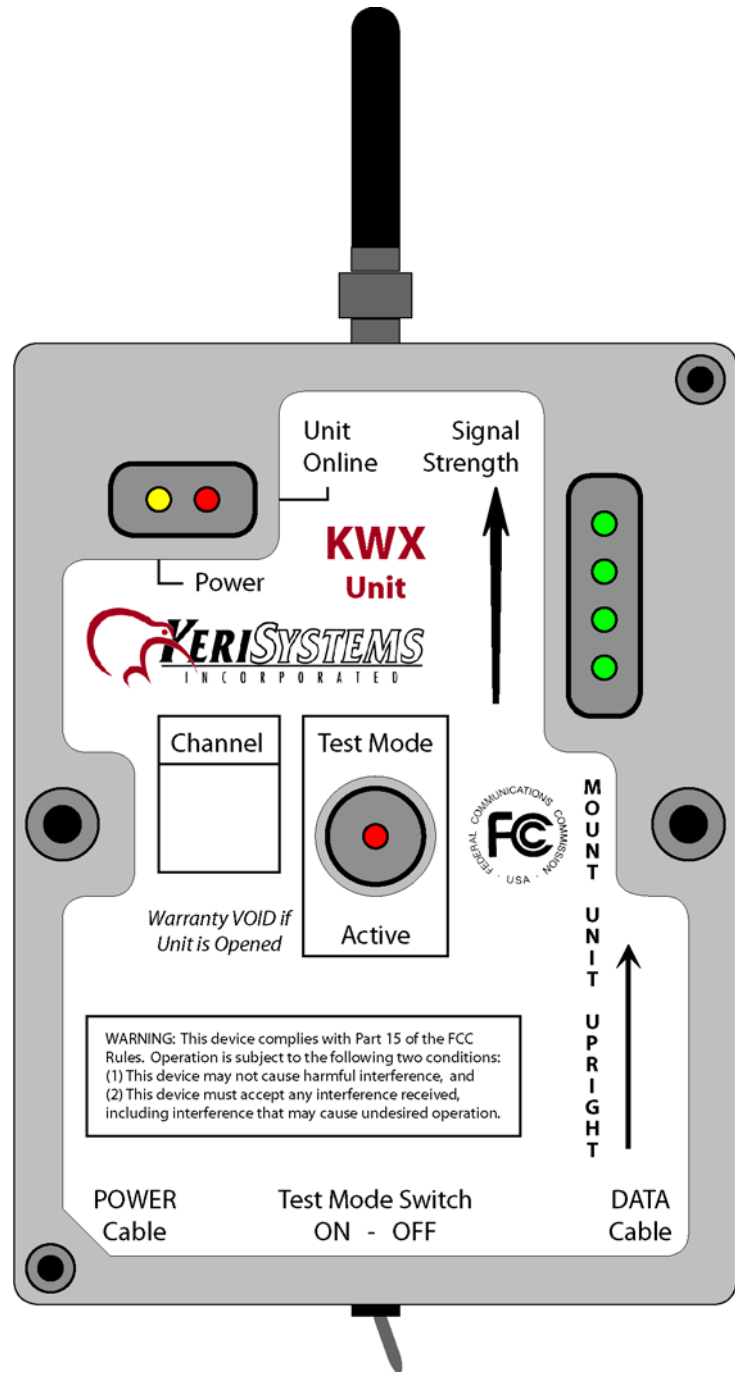

RS-485 Wireless Transceiver



Wireless 485 Network Transceiver

1.0 System Components

KWX Units

KWX units can be connected to any point in an RS-485 network line; one unit per network line. One unit, connected to the network line with the master controller, must be mounted in a central location that allows all other KWX units (connected to individual controller network spur lines) to communicate with this central unit. All wireless units have an integrated omni-directional antenna providing a “doughnut-shaped” coverage pattern (see Figure 10 on page 13).

*NOTE: For proper operation between master controller and KWX unit, the master controller **must** be a PXL-500 with firmware version 8.4.20 or greater. Entraguard controllers cannot be the master controller.*

Long-Range Antennas

The KWX unit is shipped with a unity gain “rubber-ducky” antenna. This antenna is mounted directly onto the unit, and is not designed to be removed and relocated. Three optional antennas are available for applications requiring separate antenna mounting or communication over longer distances. Seventy-two inch (six foot) extension cables are available for these optional antennas, providing greater flexibility in mounting location. These cables are specifically manufactured to minimize the amount of signal loss over the length of the cable.

NOTE: Please contact Keri Systems if a cable length greater than 72 inches is required.

Unity Gain, Omnidirectional – Recommended for use in areas where it is not practical to mount the KWX unit itself (i.e. outdoors, restricted space locations). Being omnidirectional, this antenna has the same coverage pattern as the standard, rubber-ducky antenna (see Figure 10 on page 13).

4 db Gain, Omnidirectional – Increases the coverage area of a KWX unit by approximately 25% (increasing to approximately 375 feet). When properly mounted, this antenna can help resolve fringe-area coverage problems. Being omnidirectional, this antenna has the same coverage pattern as the standard, rubber-ducky antenna, but with increased coverage in all directions (see Figure 10 on page 13).

6 db Gain, Directional Yagi – Intended for use in outdoor, point-to-point applications such as between distant buildings. The coverage distance is approximately 2,000 feet using one Yagi antenna (with the Yagi antenna at the remote site) and up to one mile with Yagi antennas used at both ends. However, the coverage area is limited to a very narrow, line-of-sight, antenna-to-antenna pattern (see Figure 11 on page 13). A Yagi antenna cannot be used as a general replacement for the standard, rubber-ducky antenna.

When considering an optional antenna, please contact Keri headquarters with your requirements so we can help match the proper antenna with your needs.



Wireless 485 Network Transceiver

2.0 Controller Network Configurations

The use of KWX Wireless Transceivers provide you with flexibility in designing a controller network configuration. The network wiring for a standard hard-wired 485 controller network appears as shown in Figure 1. In this configuration, each controller must be connected together via daisy-chained, RS-485 cabling.

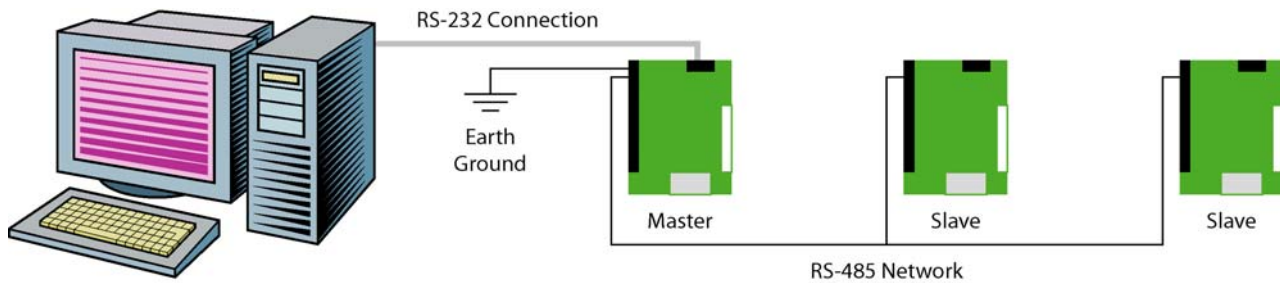

Figure 1: Standard, Hard-Wired 485 Network

The layout for Keri’s KWX Wireless Transceiver networks, however, can take a variety of forms, using multiple spurs and multiple wireless units, with each network spur being independent and the wireless unit attached at any point within the spur. This allows for shorter, more flexible network cable runs, and makes it possible to avoid difficult cable routing locations.

*NOTE: A requirement for multiple wireless spurs is that **each** spur be earth grounded.*

Examples of multiple spur/multiple unit networks are shown in Figures 2, 3, and 4.

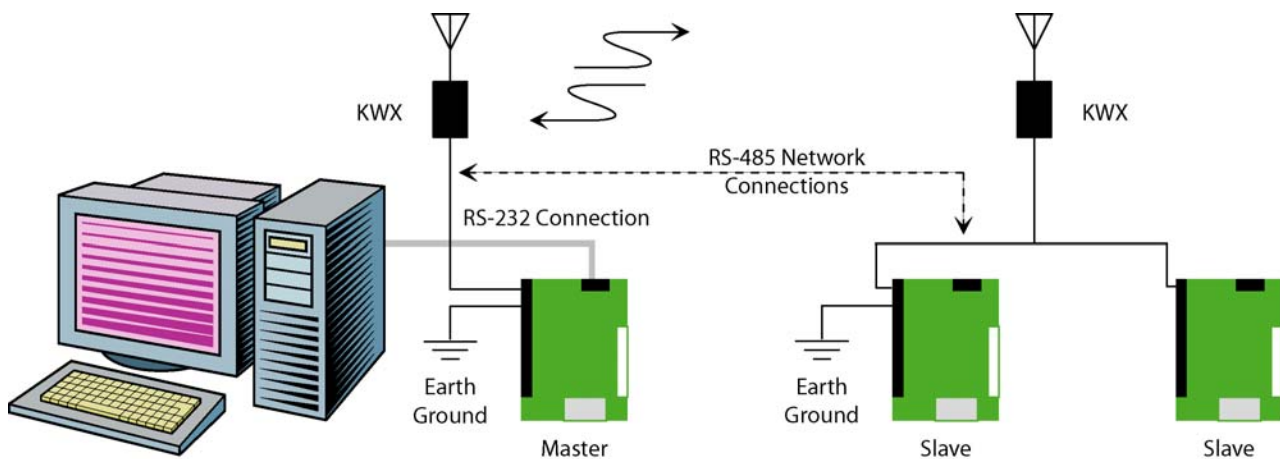

Figure 2: Basic KWX Wireless Transceiver Network

Wireless 485 Network Transceiver

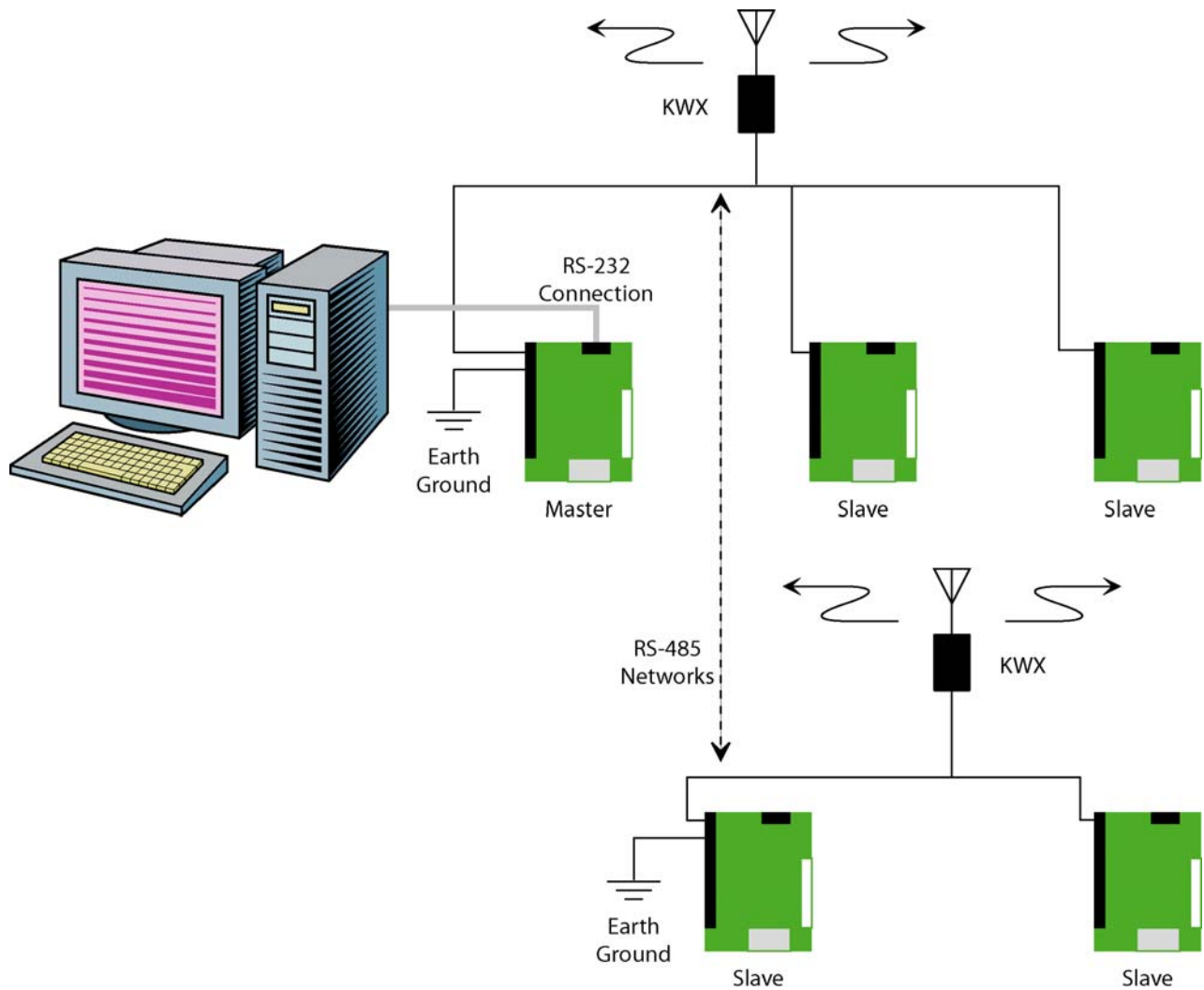

Figure 3: Wired Network with KWX Wireless Spur Configuration

Wireless 485 Network Transceiver

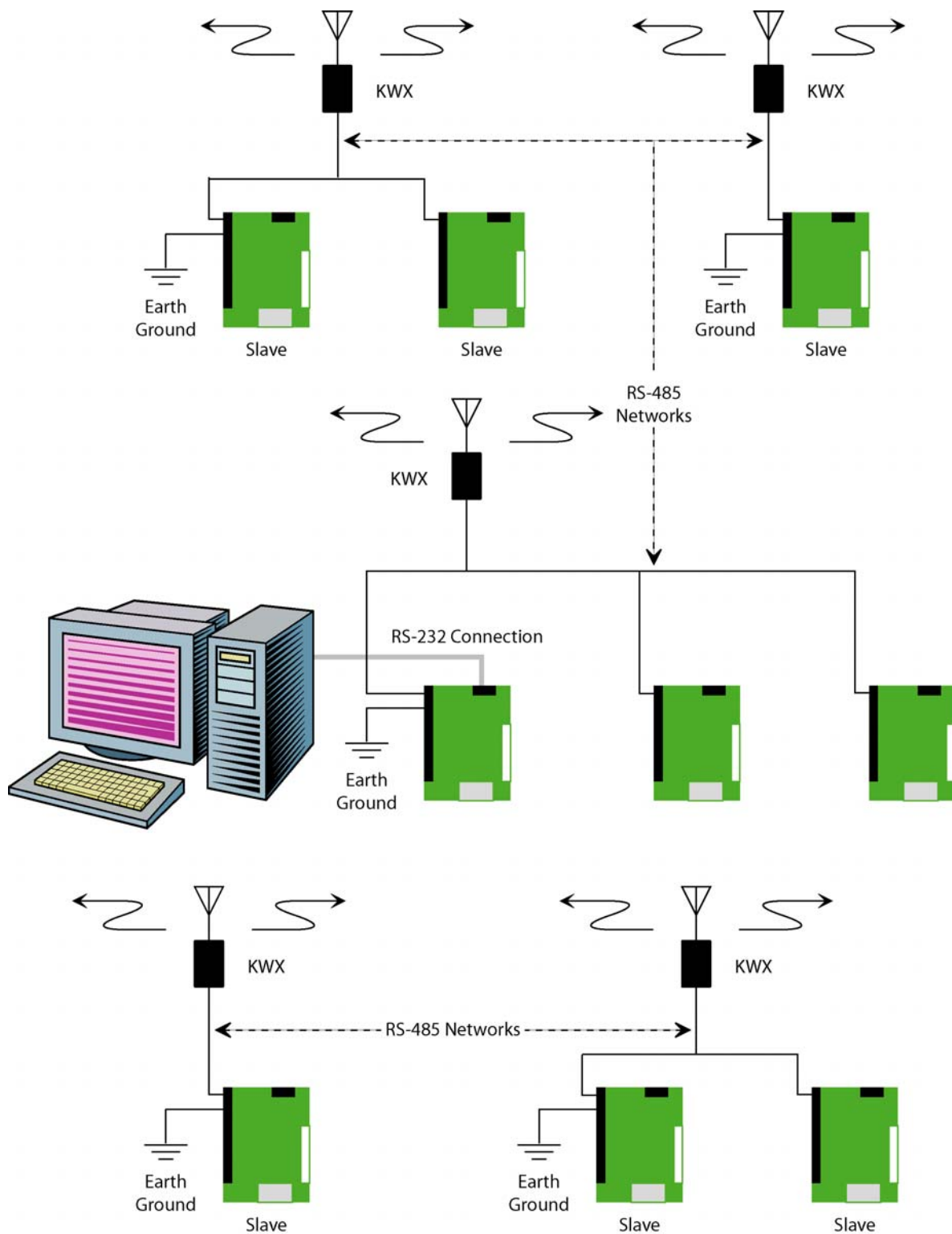

Figure 4: Wired Network with Multiple KWX Wireless Spurs Configuration

Wireless 485 Network Transceiver

3.0 System Limitations

Radio frequency transmissions are subject to various types of interference not normally encountered on copper wire. This can have the net effect of slower data transfers and an occasional missed transmission. Because of these possibilities there may be certain limitations in system using KWX units.

Monitor Mode

Monitor Mode provides the greatest level of data transmission stress to the access control system. Long-term Monitor Mode operation is dependant upon the signal strength of the KWX units. At a lower signal strength, it is possible that a communication error may occur when transferring large amounts of data. While the access control system is designed to not lose events stored in the controllers' event buffers, Monitor Mode may miss displaying an event during high data transfer periods. For this reason, Keri recommends operating in Monitor Mode at a minimum when using KWX units.

Automatic Dial-Up When Buffer Full

This feature allows a controller to automatically contact Doors and upload its event database once a certain memory threshold in the controller is reached. When this occurs, a large amount of data is transmitted in a steady stream. To protect event data integrity, Keri recommends either disabling this feature and periodically, manually collecting event data from controllers or reducing the event collection threshold to 50% (resulting in more frequent data collection with smaller event data files).

Wireless 485 Network Transceiver

4.0 Site Survey

Prior to installation, a site survey should be conducted to ensure proposed KWX installation locations will provide the required site coverage. This is done using two KWX units. Refer to Figure 5 for unit power wiring and LED functions.

NOTE: Using more than two units for the site survey invalidates the results of the survey. Only two units are necessary and only two should be used.

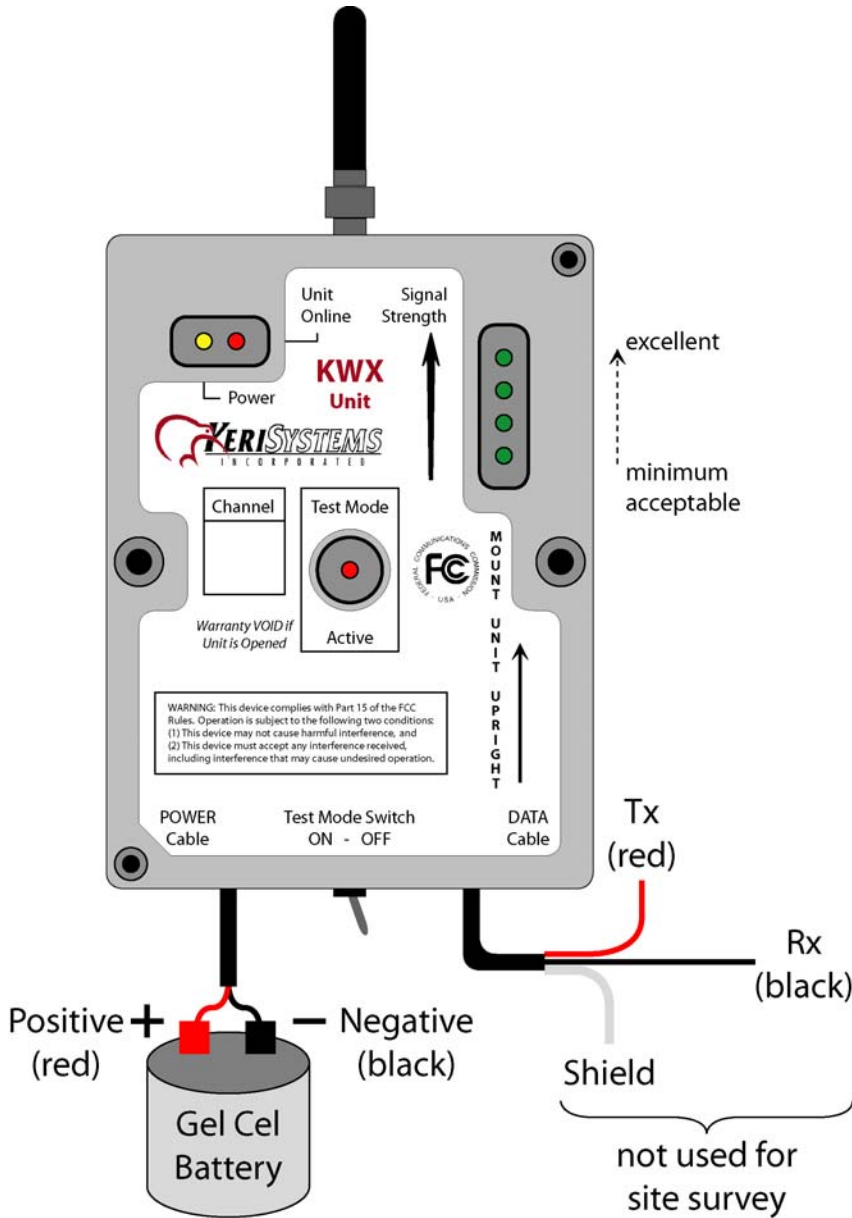

Figure 5: Pre-Installation Test Unit Power Connections

Wireless 485 Network Transceiver

1. Take the KWX unit to be connected to the master controller and designate this unit the Master Transceiver.
2. Position the Master Transceiver in the desired location near the master controller location using the following criterion:
 - Mount the unit **at least** 7 feet above the floor; the higher the unit is mounted, the greater the signal strength.
 - The unit **must be mounted upright** for proper signal coverage (refer to the unit label – see Figure 5 on page 7).
 - Do not mount the unit on to or beside metal and ensure the unit is not obscured by large metal objects (such as HVAC units and ducts, building supports and poles, etc.).
 - Ensure you will be able to route the unit cables to the controller.

The Master Transceiver must be located central to all Remote Transceivers. All Transceiver communication occurs between the Master and the Remote Transceivers. Remote Transceivers do not communicate with each other.

3. Provide 12 VDC power to the Master Transceiver using a gel cell battery or a DC power supply. The Power LED will light-up solid amber.
4. Turn the Test Mode Switch **ON**. The Test Mode Active LED will flash red and the Master Transceiver will begin transmitting test data packets.
5. Take a second KWX unit and designate this unit the Remote Transceiver. Leave the Test Mode Switch on the Remote Transceiver **OFF**.
6. Position the Remote Transceiver in a desired mounting location near a controller on an access control network spur using the same criterion as in Step 2. The two units must be mounted greater than 10 feet apart.

NOTE: Transceivers must be placed greater than 10 feet apart from each other. Unit-to-unit interference may be generated if units are placed closer than 10 feet from each other.

7. Provide 12 VDC power to the Remote Transceiver using a gel cell battery or a 12 VDC power supply. The Power LED will light-up solid amber.
8. Ensure the Test Mode Switch on the Remote Transceiver is **OFF**.

Wireless 485 Network Transceiver

9. Note the number of green Signal Strength LEDs that are lit.
 - If no LEDs are lit, you are out of the useable range of the Master Transceiver.
 - If one LED is lit, you are in a weak signal area, receiving the minimum signal from the Master Transceiver.
 - The more LEDs that are lit, the better the signal being received from the Master Transceiver.
10. Move the Remote Transceiver unit one to two feet around the mounting location to locate the area that provides the greatest signal strength and to ensure this mounting location is not a fringe location. For reliable operation, you should have two or more LEDs lit.

NOTE: Do NOT remove the attached antenna from the KWX unit and attempt to relocate the antenna using coax cabling. The unit is designed specifically for the provided antenna in its mounted location.

11. When a satisfactory mounting location is found, mark the area.
12. Repeat Steps 6 through 11 for each mounting location for each access control network spur.

NOTE: Common electrical devices can affect the site survey process, as well as unit operation. For instance, a 900 MHz wireless telephone is an example of a common device that can interfere with KWX units.



Wireless 485 Network Transceiver

5.0 Unit Mounting and Wiring Instructions

Once mounting locations have been identified via the site survey, the KWX units can be mounted and then wired in the identified areas.

5.1 Mounting the Unit

Mounting can be done in two ways. The simplest is to mount the unit directly to the wall using a piece of double-stick, foam tape (see Figure 6).

If more secure mounting is desired, the unit can be mounted directly to the wall using two screws through the two mounting holes in the body of the unit (see Figure 7).

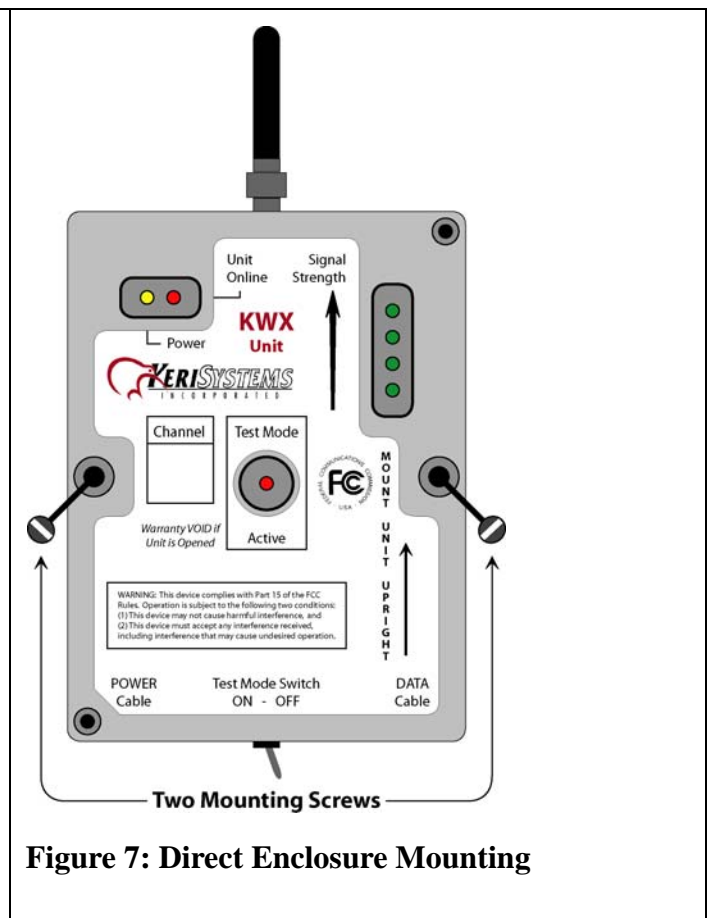
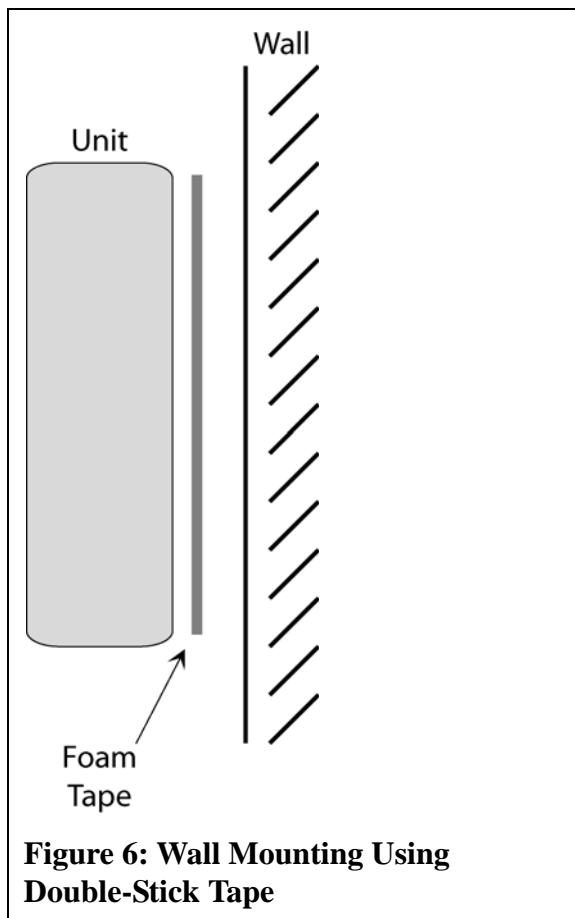

Wireless 485 Network Transceiver

5.2 Wiring the Unit

Keri KWX units have two cables: one for the power and one for network data.

5.2.1 Unit Power

Connect the power cable to either a controller or to a 12 VDC power supply as shown in Figure 8. The yellow power LED will be ON. Choose the type of connection based on the length of the run; the longer the run the greater the IR voltage drop at the end of the run. For reliable operation, the voltage measured at the unit should be 10 VDC or greater.

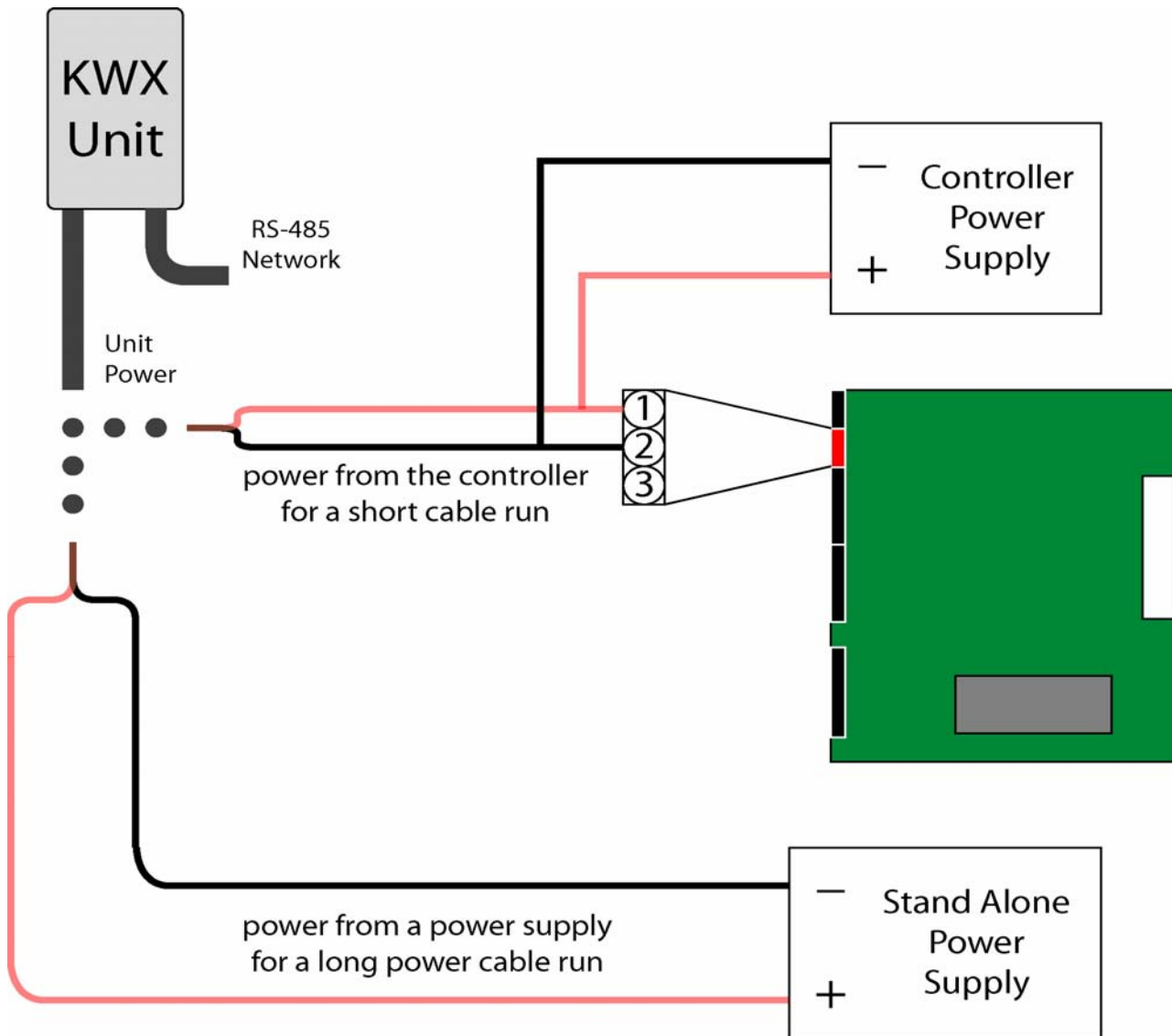

Figure 8: Power Wiring Diagram

Wireless 485 Network Transceiver

5.2.2 RS-485 Network Connections

Connect the network data line as shown in Figure 9.

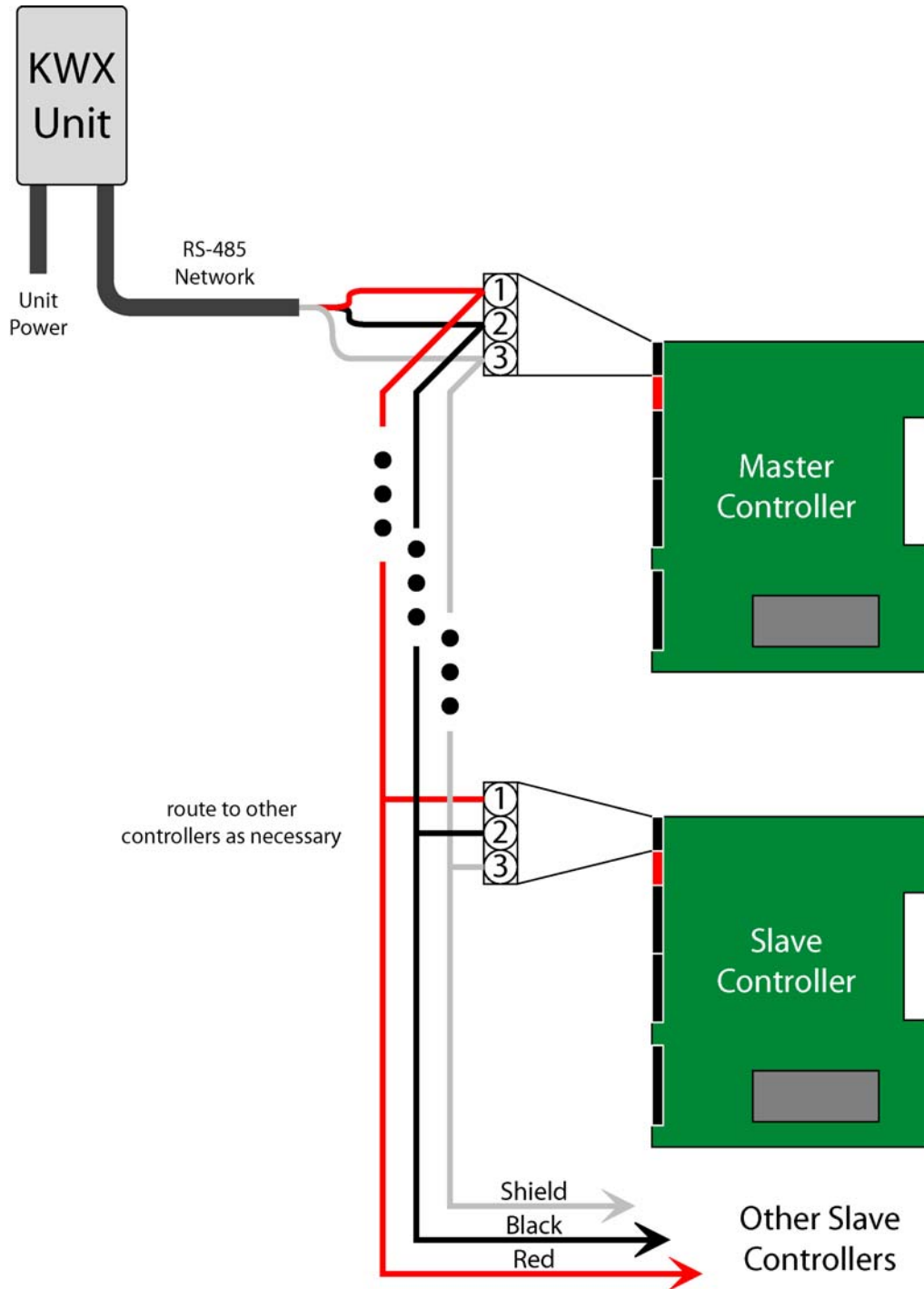

Figure 9: RS-485 Network Wiring Diagram

Wireless 485 Network Transceiver

6.0 NOTES

Antenna Coverage Patterns:

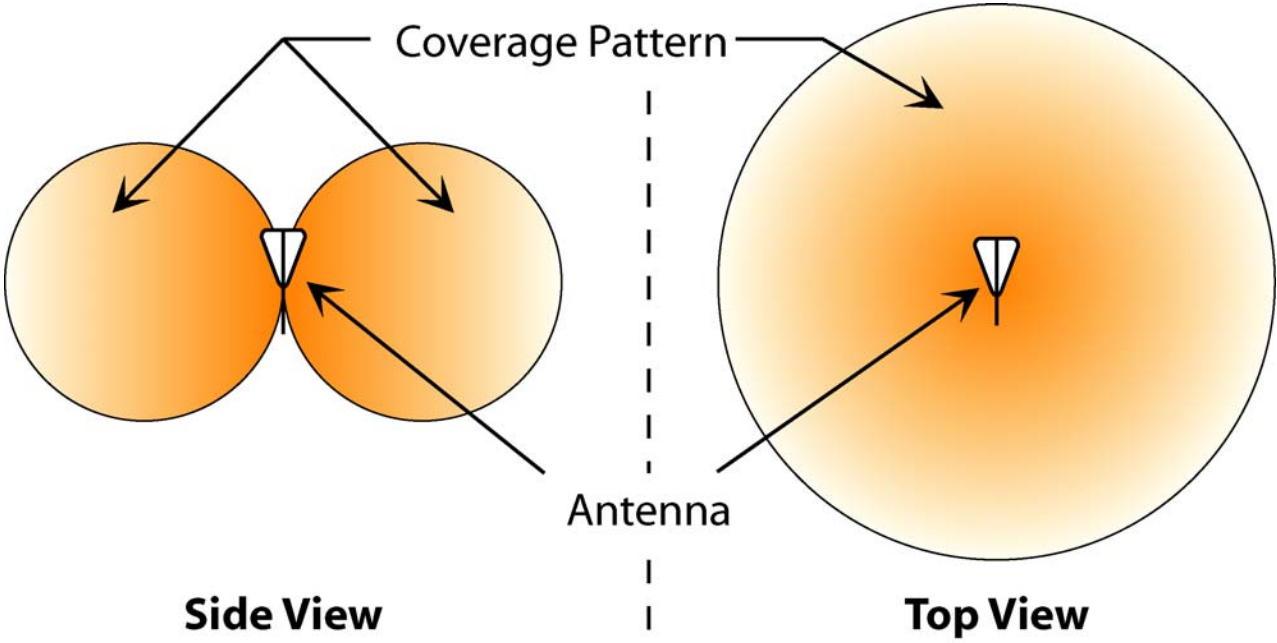

Figure 10: Omni-directional Antenna Coverage Pattern

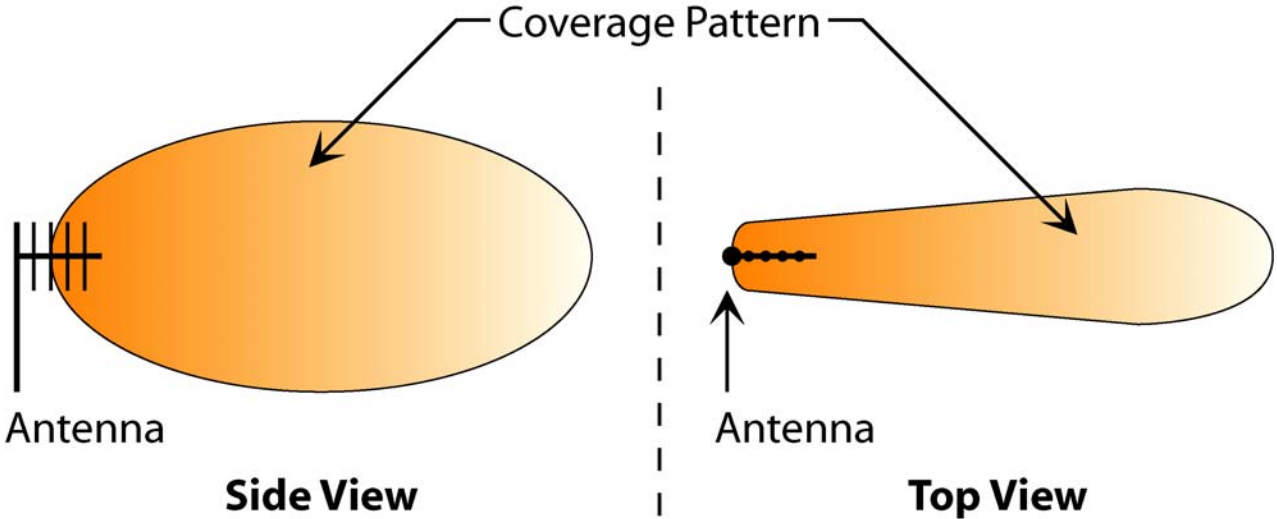

Figure 11: Yagi Antenna Point-to-Point Coverage Pattern

Wireless 485 Network Transceiver

End of Document

