

This device complies with part 15 of the FCC Rules. Operation is subject to the following two conditions: (1) This device may not cause harmful interference, and (2) this device must accept any interference received, including interference that may cause undesired operation.

# EP1501 Intelligent Controller

with Paired Reader Interface for One Physical Barrier

Installation and Specifications:

## 1. General:

The EP1501 intelligent controller provides decision making, event reporting and database storage for the Mercury hardware platform. Two reader interfaces configured as paired or alternate readers provide control for one physical barrier.

Host communication is via the on-board 10-BaseT/100Base-TX Ethernet port.



Note: For UL compliance, the Power Sourcing Equipment (PSE) such as a PoE enabled network switch and/or PoE power injectors must be UL Listed under UL294B.

Reader port 1 can accommodate a reader that utilizes TTL (D1/D0, Clock/Data), F/2F, or 2-wire RS-485 device signaling, also provides tri-state LED control, and buzzer control (one wire LED mode only). This port can also utilize multiple 2-wire RS-485 multi-dropped devices, such as up to two readers or up to eight remote serial I/O devices.

Reader port 2 can accommodate a reader that utilizes TTL (D1/D0, Clock/Data), or F/2F signaling, also provides tri-state LED control, and buzzer control (one wire LED mode only). Two Form-C contact relay outputs may be used for door strike control or alarm signaling. The relay contacts are rated at 2 A @ 30 Vdc, dry contact configuration. Two inputs are provided that may be used for monitoring the door contact, exit push button or alarm contact. Input circuits can be configured as unsupervised or supervised. The EP1501 requires Power over Ethernet (PoE) or 12 Vdc for power. The EP1501 may be mounted in a 3-gang switch box; a mounting plate is supplied with the unit, or may be mounted in an enclosure; the supplied mounting plate has mounting holes that match the MR50 mounting footprint.

## 2. EP1501 Hardware:

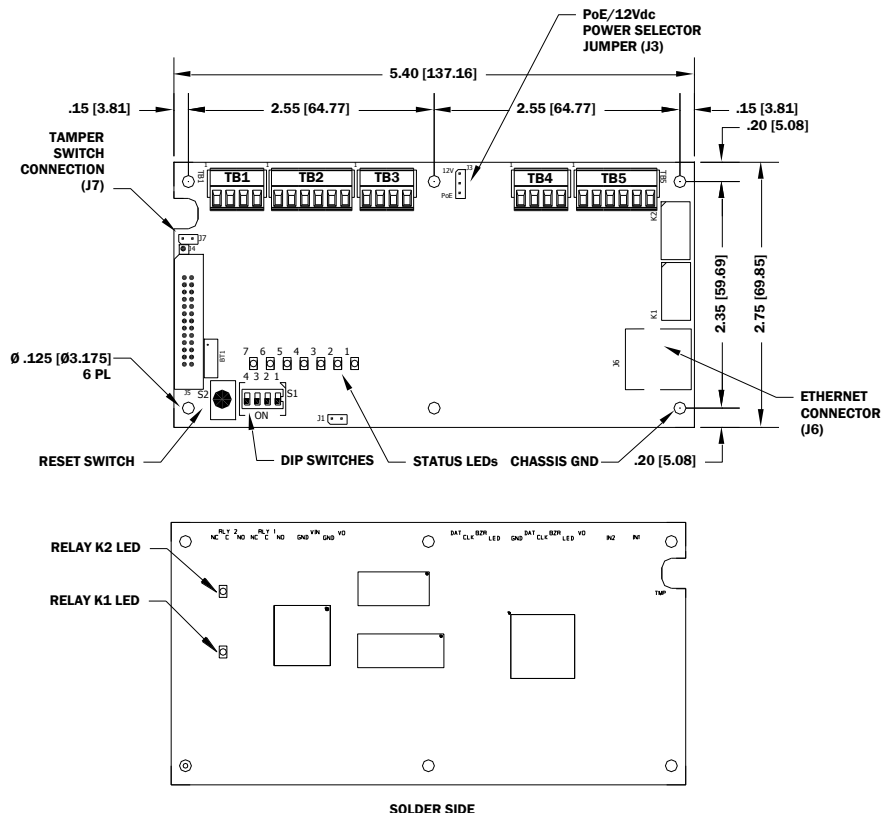

Information Subject to Change Without Notice

### 3. EP1501 Wiring and Setup:

EP1501 CONNECTIONS		
TB1-1	IN1	Input 1
TB1-2	IN1	
TB1-3	IN2	Input 2
TB1-4	IN2	
TB2-1	VO	Reader 1 Power Output – 12 Vdc
TB2-2	LED	Reader 1 LED Output
TB2-3	BZR	Reader 1 Buzzer Output
TB2-4	CLK	Reader 1 CLK/Data 1/TR+
TB2-5	DAT	Reader 1 DAT/Data 0/TR-
TB2-6	GND	Reader 1 Ground
TB3-1	LED	Reader 2 LED Output
TB3-2	BZR	Reader 2 Buzzer Output
TB3-3	CLK	Reader 2 CLK/Data 1 Input
TB3-4	DAT	Reader 2 DAT/Data 0 Input
TB4-1	VO	Auxiliary Power Output – 12 Vdc
TB4-2	GND	Auxiliary Power Output Ground
TB4-3	VIN	Input Power – 12 Vdc (from local power supply)
TB4-4	GND	Input Power Ground
TB5-1	NO	Relay K1 – Normally Open Contact
TB5-2	1-C	Relay K1 – Common Contact
TB5-3	NC	Relay K1 – Normally Closed Contact
TB5-4	NO	Relay K2 – Normally Open Contact
TB5-5	2-C	Relay K2 – Common Contact
TB5-6	NC	Relay K2 – Normally Closed Contact

Jumpers:

JUMPERS	SET AT	DESCRIPTION
J1	N/A	Factory Use Only
J2	N/A	Factory Use Only
J3	PoE	EP1501 powered from the Ethernet connection
	12V	EP1501 powered from an local 12 Vdc power source connected to TB4-3 (VIN), TB4-4 (GND)
J4	N/A	Factory Use Only
J5	N/A	Factory Use Only
J6	N/A	10-Base-T/100Base-TX Ethernet Connection
J7		Cabinet Tamper Switch Input: short = tamper secure

### DIP Switches:

The four switches on S1 DIP switch configure the operating mode of the EP1501 processor. DIP switches are read on power-up except where noted. Pressing switch S2 causes the EP1501 to reboot.

1	2	3	4	Definitions
OFF	OFF	OFF	OFF	Normal operating mode.
ON	X	X	X	After initialization, enable default User Name (admin) and Password (password). The switch is read on the fly, no need to re-boot. See IT Security section for additional information.
OFF	ON	X	OFF	Use factory default communication parameters.
ON	ON	X	OFF	Use OEM default communication parameters. Contact system manufacture for details. See Bulk Erase section below.
X	X	ON	X	Disable TLS secure link. Switch is read only when logging on.

All other switch settings are unassigned and reserved for future use.

### Factory Default Communication Parameters:

Network: static IP address: 192.168.0.251

Subnet Mask: 255.255.0.0

Default Gateway: 192.168.0.1

DNS Server: 192.168.0.1

Host port: IP server, no encryption, port 3001, communication address: 0

## 4. Bulk Erase Configuration Memory:

The bulk erase function can be used for the following purposes:

- Erase all configuration and cardholder database (sanitize board)
- Update OEM default parameters after OEM code has been changed
- Recover from database corruption causing EP1501 board to continuously reboot

If clearing the memory does not correct the initialization problem, contact technical support.

Bulk Erase Steps: **Do not remove power during steps 1-8.**

1. Set S1 DIP switches to: 1 & 2 "ON", 3 & 4 "OFF".
2. Apply power to the EP1501 board.
3. Watch for LEDs 1 & 2 and 3 & 4 to alternately flash at a 0.5 second rate.
4. Within 10 seconds of powering up, change switches 1 or 2 to "OFF". If these switches are not changed, the EP1501 board will power up using the OEM default communication parameters.
5. LED 2 will flash indicating that the configuration memory is being erased.
6. Full memory erase takes up to 60 seconds.
7. When complete, only LEDs 1 & 4 will flash for 8 seconds.
8. The EP1501 board will reboot 8 seconds after LEDs 1 & 4 stop flashing (no LEDs are on during this time).

## 5. Input Power:

The EP1501 is powered by one of two ways (jumper selected, J3):

- Power is supplied via the Ethernet connection using PoE, fully compliant to IEEE 802.3af
- Or local 12 Vdc power supply, TB4-3 (VIN), TB4-4 (GND)

## 6. Communication Wiring:

The EP1501 controller communicates to the host via the on-board 10-BaseT/100Base-TX Ethernet interface.

## 7. Reader/Serial I/O Device Wiring:

Reader port 1 supports TTL (D1/D0, Clock/Data), F/2F, or 2-wire RS-485 device(s). Reader port 2 supports TTL (D1/D0, Clock/Data), or F/2F. Power to reader port 1 is 12 Vdc at 180 mA maximum. The reader connected to reader port 2 may be powered from the 12 Vdc auxiliary power supply output; TB4-1 and TB4-2. Readers that require different voltage or have high current requirements should be powered separately. Refer to the reader manufacture specifications for cabling requirements. In the 2-wire LED mode, the buzzer output is used to drive the second LED. Reader port configuration is set via the host software.

Reader port 1 can support up to eight 2-wire RS-485 remote serial I/O devices using MSP1 protocol or up to two OSDP devices. If two OSDP devices are used, reader port 2 will not support a third reader. If only one OSDP device is configured, then reader port 2 is available for a second reader. The maximum cable length is 2000 ft. (610 m). Do not terminate any RS-485 devices connected to reader port 1.

 When powering remote device(s) from the EP1501, be cautious not to exceed the maximum current limit. Cable gauge must also be evaluated. See specifications section for details.

### Reader Wiring Diagrams:

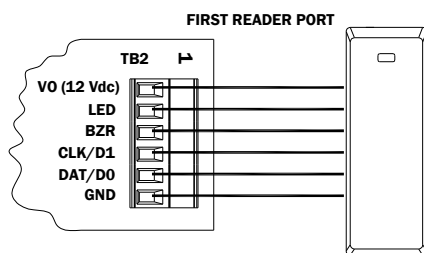

**Reader Port 1**  
Typical D1/D0 or Clock/Data Reader

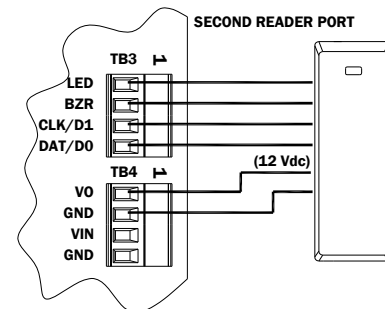

**Reader Port 2**  
Typical D1/D0 or Clock/Data Reader

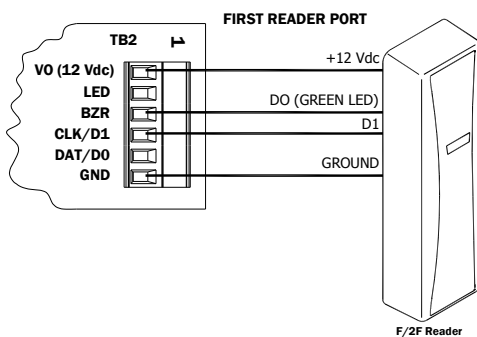

**Reader Port 1**  
Typical Unsupervised F/2F Reader

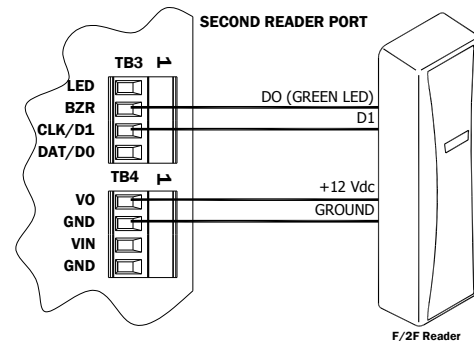

**Reader Port 2**  
Typical Unsupervised F/2F Reader

\* Inputs on supervised F/2F readers may be unsupervised or supervised (supervised shown).

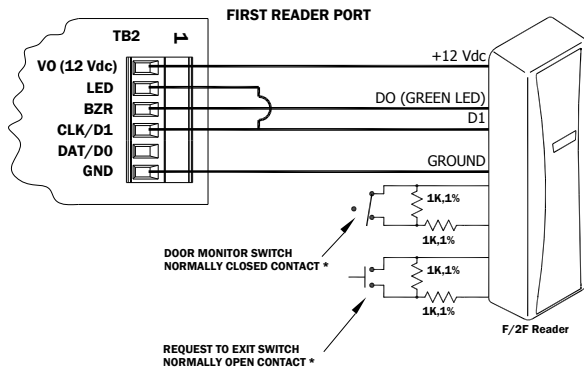

**Reader Port 1  
Typical Supervised F/2F Reader**

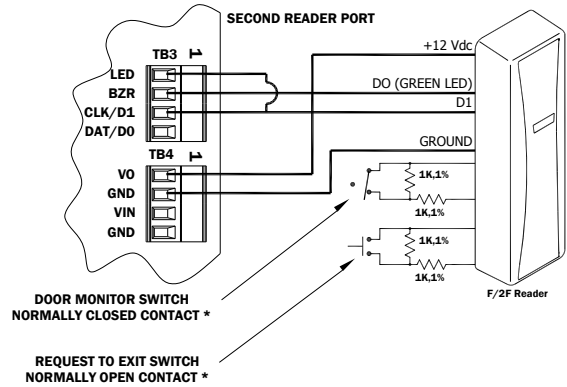

**Reader Port 2  
Typical Supervised F/2F Reader**

⚠ Jumper D1 and LED on supervised F/2F readers

REFER TO THE APPROPRIATE REMOTE SERIAL I/O DEVICE INSTALLATION MANUAL FOR ADDRESS AND BAUD RATE SETTINGS. DO NOT TERMINATE ANY OF THE DEVICES ON THE RS-485 MULTI-DROP COMMUNICATION BUS. EACH REMOTE SERIAL I/O DEVICE MUST BE CONFIGURED WITH A UNIQUE COMMUNICATION ADDRESS. A MAXIMUM OF EIGHT REMOTE SERIAL I/O DEVICES MAY BE CONNECTED TO READER PORT 1.

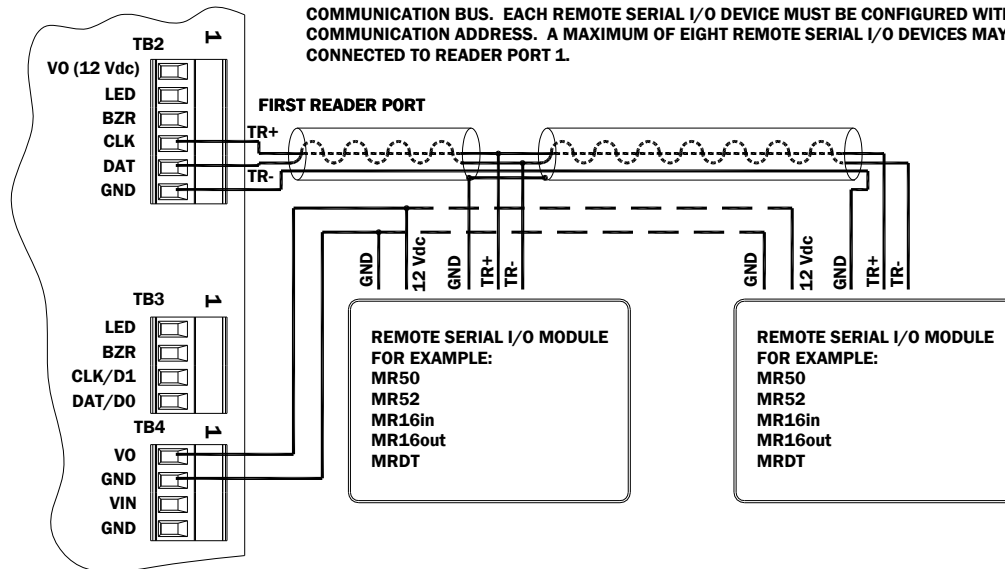

**Reader Port 1 - Remote Serial I/O Devices using MSP1 Protocol (2-Wire RS485)**

REFER TO THE APPROPRIATE REMOTE SERIAL I/O DEVICE INSTALLATION MANUAL FOR ADDRESS AND BAUD RATE SETTINGS. DO NOT TERMINATE ANY OF THE DEVICES ON THE RS-485 MULTI-DROP COMMUNICATION BUS. EACH OSDP DEVICE MUST BE CONFIGURED WITH A UNIQUE COMMUNICATION ADDRESS. A MAXIMUM OF TWO OSDP DEVICES MAY BE CONNECTED TO READER PORT 1.

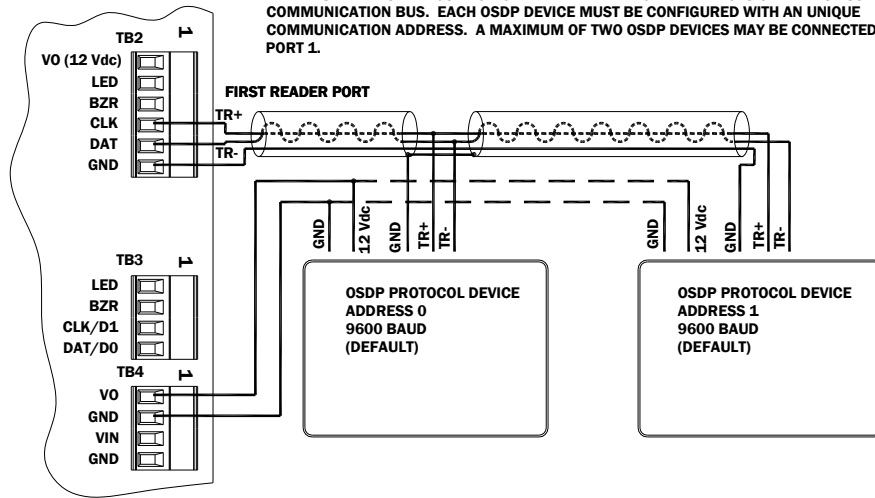

**Reader Port 1 - OSDP Protocol Devices (2-Wire RS-485)**

### 8. Input Circuit Wiring:

Typically, these inputs are used to monitor door position, request to exit, or alarm contacts. Input circuits can be configured as unsupervised or supervised. When unsupervised, reporting consists of only the open or closed states.

When configured as supervised, the input circuit will report not only open and closed, but also open circuit, shorted, grounded\*, and foreign voltage\*. A supervised input circuit requires two resistors be added to the circuit to facilitate proper reporting. The standard supervised circuit requires 1k ohm, 1% resistors and should be located as close to the sensor as possible. Custom end of line (EOL) resistances may be configured via the host software.

\* Grounded and foreign voltage states are not a requirement of UL 294 and therefore not verified by UL.

The input circuit wiring configurations shown are supported but may not be typical:

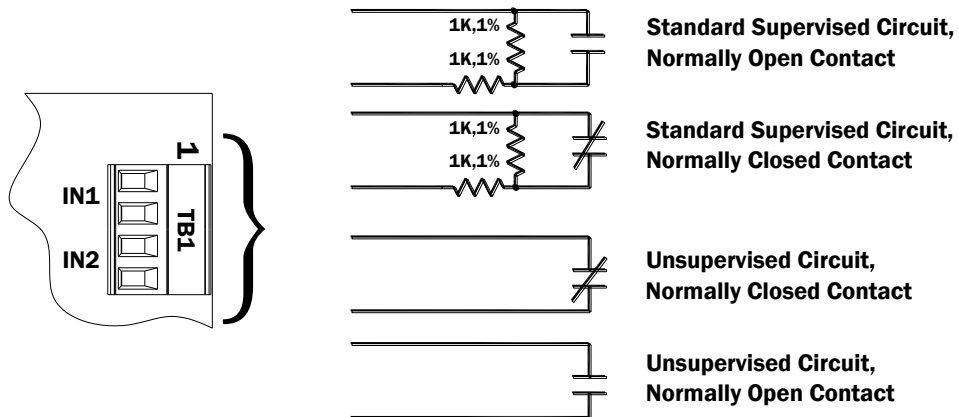

## 9. Relay Circuit Wiring:

Two Form-C contact relays are provided for controlling door lock mechanisms or alarm signaling devices. The relay contacts are rated at 2 A @ 30 Vdc, dry contact configuration. Each relay has a Common pole (C), a Normally Open pole (NO) and a Normally Closed pole (NC). When you are controlling the delivery of power to the door strike, the Normally Open and Common poles are used. When momentarily removing power to unlock the door, as with a mag lock, the Normally Closed and Common poles are used. Check with local building codes for proper egress door installation.

Door lock mechanisms can generate EMF feedback to the relay circuit that can cause damage and premature failure of the relay. For this reason, it is recommended that either a diode or MOV (metal oxide varistor) be used to protect the relay. Wire should be of sufficient gauge to avoid voltage loss.

 From the Auxiliary output, the EP1501 can provide 12 Vdc power for external devices provided that the maximum current is not exceeded. See the specifications section for details. If a local power supply is used, it must be UL Listed Class 2 rated.

### Relay Circuit Wiring Diagrams:

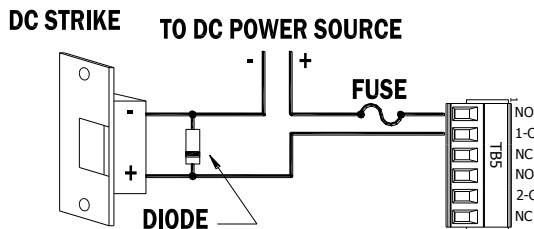

### Diode Selection:

Diode current rating: 1x strike current  
 Diode breakdown voltage: 4x strike voltage  
 For 12 Vdc or 24 Vdc strike, diode 1N4002 (100V/1A) typical.

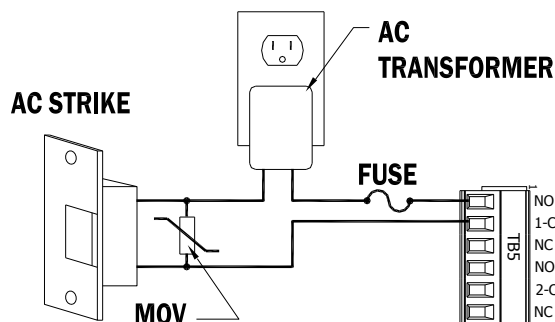

### MOV Selection:

Clamp voltage: 1.5x Vac RMS.  
 Use UL recognized MOV with appropriate ratings

## 10. Memory Backup Battery:

The SRAM is backed up by a rechargeable battery when input power is removed. This battery should retain the data for a minimum of 3 days. If data in the SRAM is determined to be corrupt after power up, all data, including flash memory, is considered invalid and is erased. All configuration data must be re-downloaded.

 **Note:** The initial charge of the battery may take up to 48 hours to be fully charged.

## 11. Status LEDs:

**Power-up:** All LED's **OFF**.

### Initialization:

LED's 1, 2, 3, 4, 5, 6, and 7 are sequenced during initialization. LED's 1, 3, and 4 are turned ON for approximately 1.5 seconds after the hardware initialization has completed, then the application code is initialized. The amount of time the application takes to initialize depends on the size of the database, about 3 seconds without a card database. Each 10,000 cards will add about 3 seconds to the application initialization. When LED's 1, 2, 3 and 4 flash at the same time, data is being read from or written to flash memory, do not cycle power when in this state.

If the sequence stops or repeats, perform the Bulk Erase Configuration Memory procedure in section 4. If clearing the memory does not correct the initialization problem, contact technical support.

### Running:

After initialization is complete, the LEDs have the following meanings: At power up, LEDs 2 through 7 are turned ON then OFF in sequence.

LED	DESCRIPTION
1	Off-Line / On-Line: Off-Line = 20 % ON, On-Line = 80 % ON
2	Host Communication Activity
3	Readers (combined): Clock/Data or D1/D0 Mode = Flashes when Data is Received, Either Input. RS-485 Mode = Flashes when Transmitting Data F/2F Mode = Flashes when Data/Acknowledgment is Received
4	Input IN1 Status: OFF = Inactive, ON = Active, Flash = Trouble See Note 1
5	Input IN2 Status: OFF = Inactive, ON = Active, Flash = Trouble See Note 1
6	Cabinet Tamper
7	Reserved for Future Use
YEL	Ethernet Speed: OFF = 10 Mb/S, ON = 100 Mb/S
GRN	OFF = No Link, ON = Good Link, Flashing = Ethernet Activity

Note 1: If this input is defined, every three seconds the LED is pulsed to its opposite state for 0.1 seconds, otherwise, the LED is off.

## 12. IT Security

When installing the EP1501, it is important to ensure that it done in a secure manner.

Upon installation, the user accounts to the web configuration page should be created with secure passwords, and that all DIP switches are in the off position for the normal operating mode. The EP1501 is shipped from the factory with a default login account, which is enabled when DIP 1 is moved from OFF to ON. The default login user name and password will be available for five minutes once enabled. Therefore, it is important that at least one user account is defined, and the DIP switches are set to OFF before the EP1501 is commissioned. It is also highly recommended not to configure the EP1501 with an IP address that is accessible from the public Internet.

To further enhance network security, options are available to disable SNMP, Zeroconf discovery, as well as the web configuration module itself. Additionally, data encryption can also be enabled over the host communication port.



### 13. Specifications:

The interface is for use in low voltage, Class 2 circuits only.

The installation of this device must comply with all local fire and electrical codes.

Power Input: PoE Power Input 12.95 W, compliant to IEEE 802.3af  
or  
12 Vdc  $\pm$  10 %, 200 mA minimum, 900 mA maximum (local power supply)

Power Output: 12 Vdc @ 650 mA including reader and Auxiliary Power output



Note: For UL, the Power Sourcing Equipment (PSE) such as a PoE enabled network switch and/or PoE power injectors must be UL Listed under UL294B.

SRAM Backup Battery: Rechargeable battery

Host Communication: Ethernet: 10-BaseT/100Base-TX

Inputs: Two unsupervised/supervised, Programmable End of Line resistors, 1k/1k ohm, 1 %, ¼ watt standard  
One unsupervised input dedicated for cabinet tamper

Outputs: Two relays: Form-C contacts: 2 A @ 30 Vdc, resistive

Reader Interface:

Power: 12 Vdc  $\pm$  10 %: PoE or local power supply, 180 mA maximum

Data Inputs: Reader port 1: TTL compatible, F/2F or 2-wire RS-485  
Reader port 2: TTL compatible or F/2F

LED Output: TTL compatible, high > 3 V, low < 0.5 V, 5 mA source/sink maximum

Buzzer Output: Open collector, 12 Vdc open circuit maximum, 40 mA sink maximum

Cable Requirements:

Power: 1 twisted pair, 18 AWG (when using local 12 Vdc power supply)

Ethernet: CAT-5, minimum

Alarm Input: 1 twisted pair per input, 30 ohm maximum

Outputs: As required for the load

Reader data (TTL): 6-conductor, 18 AWG, 500 ft. (152 m) maximum

Reader data (F/2F): 4-conductor, 18 AWG, 500 ft. (152 m) maximum

Reader data (RS-485): 1 twisted pair with drain wire and shield, 24 AWG, 120 ohm impedance, 2000 ft. (610 m) maximum

Environmental:

Temperature: Storage -55 to +85 °C  
Operating 0 to +70 °C

Humidity: 5 to 95 % RHNC

Mechanical:

Dimension: 5.5 in. (140 mm) W x 2.75 in. (70 mm) L x 0.96 in. (24 mm) H without bracket  
5.5 in. (140 mm) W x 3.63 in. (92 mm) L x 1.33 in. (34 mm) H with bracket

Weight: 3.8 oz. (106.4 g) without bracket  
4.7 oz. (133.3 g) with bracket

## 14. Additional Mounting Information:

Sources for the optional items shown below:

- 3-gang stainless steel blank cover. Available from:  
Leviton: part number 84033-40  
Graybar: part number 88158404
- Magnetic switch set: G.R.I. part number: 505

### Mounting Plate Dimensions:

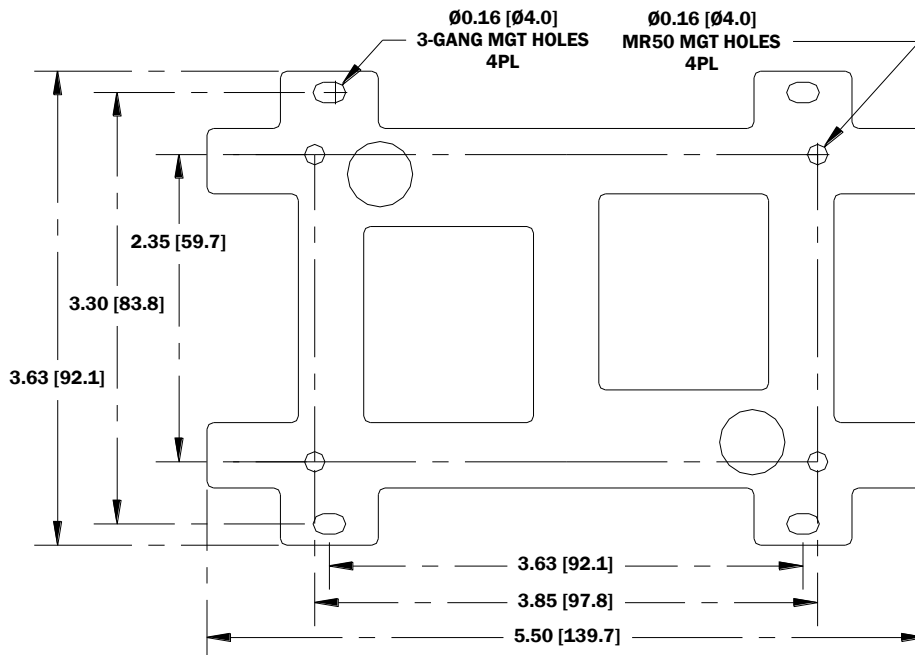
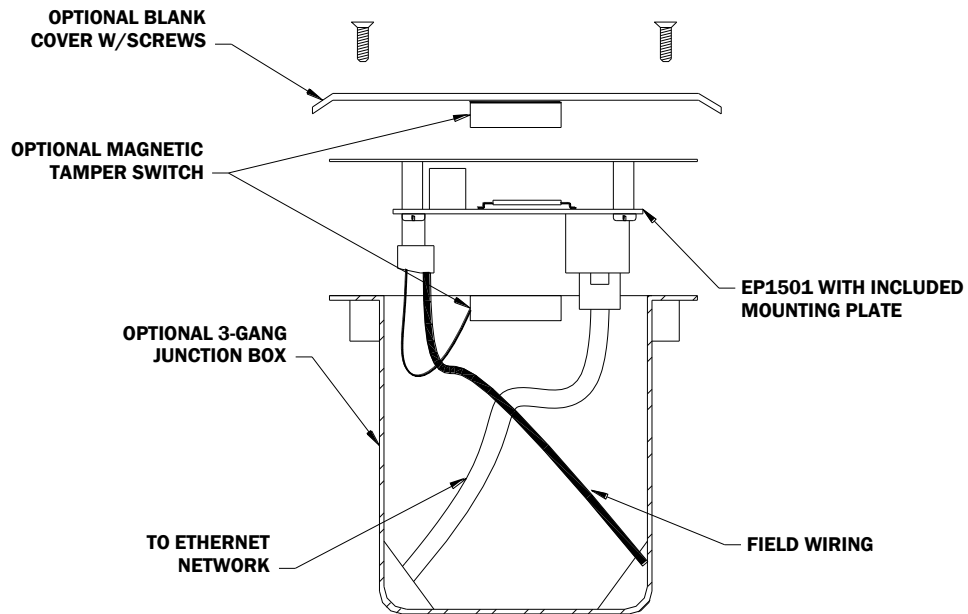

## **Warranty**

Mercury Security warrants the product is free from defects in material and workmanship under normal use and service with proper maintenance for one year from the date of factory shipment. Mercury Security assumes no responsibility for products damaged by improper handling or installation. This warranty is limited to the repair or replacement of the defective unit.

There are no expressed warranties other than set forth herein. Mercury Security does not make, nor intends, nor does it authorize any agent or representative to make any other warranties, or implied warranties, and expressly excludes and disclaims all implied warranties of merchantability or fitness for a particular purpose.

Returns must be accompanied by a Return Material Authorization (RMA) number obtained from customer service, and prepaid postage and insurance.

## **Liability**

The Interface should only be used to control exits from areas where an alternative method for exit is available. This product is not intended for, nor is rated for operation in life-critical control applications. Mercury Security is not liable under any circumstances for loss or damage caused by or partially caused by the misapplication or malfunction of the product. Mercury Security's liability does not extend beyond the purchase price of the product.